



中国认可
国际互认
检测
TESTING
CNAS L0446



Test Report

Verified code: 259428

Report No.: E20220414157601-1-G1

Customer: Lumi United Technology Co., Ltd.
Address: Room 801-804, Building 1, Chongwen Park, Nanshan iPark, No. 3370, Liuxian Avenue, Fuguang Community, Taoyuan Residential District, Nanshan District, Shenzhen, China
Sample Name: Cube T1 Pro
Sample Model: CTP-R01
Receive Sample Date: Apr.15,2022
Test Date: Apr.19,2022 ~ May.11,2022
Reference Document: ETSI EN 301 489-17 V3.2.4 (2020-09)ElectroMagnetic Compatibility (EMC)standard for radio equipment and services;Part 17: Specific conditions forBroadband Data Transmission Systems;Harmonised Standard covering the essential requirements of article 3.1(b) of Directive 2014/53/EU ETSI EN 301 489-1 V2.2.3(2019-11)ElectroMagnetic Compatibility (EMC)standard for radio equipment and services;Part 1: Common technical requirements;Harmonised Standard for ElectroMagnetic Compatibility EN55032:2015/A11:2020 Electromagnetic compatibility of multimedia equipment – Emission Requirements EN 55035:2017/A11:2020 Electromagnetic compatibility of multimedia equipment - Immunity requirements
Test Result: Pass

Prepared by: *Huang Lifang* Reviewed by: *Wu Haoming* Approved by: *Xiao Liang*

GUANGZHOU GRG METROLOGY & TEST CO., LTD

Issued Date: 2022-05-27

Guangzhou GRG Metrology & Test Co., Ltd.

Address: No.163, Pingyun Road, West of Huangpu Avenue, Guangzhou, Guangdong, China
Tel: (+86) 400-602-0999 FAX: (+86) 020-38698685 Web: <http://www.grgtest.com>



Statement

1. The report is invalid without "special seal for inspection and testing"; some copies are invalid; The report is invalid if it is altered or missing; The report is invalid without the signature of the person who prepared, reviewed and approved it.
2. The sample information is provided by the client and responsible for its authenticity; The content of the report is only valid for the samples sent this time.
3. When there are reports in both Chinese and English, the Chinese version will prevail when the language problems are inconsistent.
4. If there is any objection concerning the report, please inform us within 15 days from the date of receiving the report.
5. Without the agreement of the laboratory, the client is not authorized to use the test results for unapproved propaganda.

----- The following blanks -----

Table of Contents

1.	TEST RESULT SUMMARY.....	6
2.	GENERAL DESCRIPTION OF EUT.....	7
2.1	APPLICANT.....	7
2.2	MANUFACTURER.....	7
2.3	BASIC DESCRIPTION OF EQUIPMENT UNDER TEST.....	7
2.4	TEST MODE.....	8
2.5	LOCAL SUPPORTIVE INSTRUMENTS.....	8
2.6	CONFIGURATION OF SYSTEM UNDER TEST.....	8
3.	LABORATORY AND ACCREDITATIONS.....	9
3.1	LABORATORY.....	9
3.2	ACCREDITATIONS.....	9
3.3	MEASUREMENT UNCERTAINTY.....	10
4.	LIST OF USED TEST EQUIPMENT AT GRGT.....	11
4.1	LIST OF USED TEST EQUIPMENT.....	11
5.	EMISSION TEST.....	13
5.1	RADIATED EMISSION MEASUREMENT (RE).....	13
5.1.1	LIMITS.....	13
5.1.2	TEST PROCEDURE.....	14
5.1.3	TEST SETUP.....	15
5.1.4	DATA SAMPLE.....	16
5.1.5	PHOTOGRAPH OF THE TEST ARRANGEMENT.....	17
5.1.6	TEST RESULTS.....	18
6.	IMMUNITY TEST.....	22
6.1	GENERAL DESCRIPTION.....	22
6.2	GENERAL PERFORMANCE CRITERIA DESCRIPTION (ETSI EN 301 489-1/17).....	23
6.2.1	GENERAL PERFORMANCE CRITERIA.....	23
6.2.2	MINIMUM PERFORMANCE LEVEL.....	25
6.2.3	PERFORMANCE CRITERIA FOR CONTINUOUS PHENOMENA.....	26
6.2.4	PERFORMANCE CRITERIA FOR TRANSIENT PHENOMENA.....	26
6.3	GENERAL PERFORMANCE CRITERIA DESCRIPTION (EN 55035).....	27
6.3.1	GENERAL PERFORMANCE CRITERIA.....	27
6.4	ELECTROSTATIC DISCHARGE(ESD).....	28
6.4.1	TEST SPECIFICATION.....	28
6.4.2	TEST PROCEDURE.....	28
6.4.3	TEST SETUP.....	29
6.4.4	PHOTOGRAPH OF THE TEST ARRANGEMENT.....	30
6.4.5	TEST RESULTS.....	31
6.5	RADIATED RADIO-FREQUENCY ELECTROMAGNETIC FIELD (RS).....	32
6.5.1	TEST SPECIFICATION.....	32
6.5.2	TEST PROCEDURE.....	32
6.5.3	TEST SETUP.....	33

6.5.4	PHOTOGRAPH OF THE TEST ARRANGEMENT	34
6.5.5	TEST RESULTS	35
6.6	POWER FREQUENCY MAGNETIC FIELD IMMUNITY TEST.....	36
6.6.1	TEST SPECIFICATION	36
6.6.2	TEST PROCEDURE.....	36
6.6.3	TEST SETUP	36
6.6.4	PHOTOGRAPH OF THE TEST ARRANGEMENT	37
6.6.5	TEST RESULTS	38
APPENDIX A. PHOTOGRAPHS OF EUT		39

----- The following blanks -----

REPORT ISSUED HISTORY

Report Version	Report No.	Description	Compile Date
1.0	E20220414157601-1	Original Issue	2022-05-06
2.0	E20220414157601-1-G1	Update	2022-05-26

Version 2.0:

1. On the basis of the original report, updated the Calibration Due about the model TAP01018048 of Preamplifiers.
2. This report instead the report E20220414157601-1, and from the date of issuance of this report, the report which being replaced become invalid.

----- The following blanks -----

1. TEST RESULT SUMMARY

Emissions

Test Item	Test mode	Equipment test requirement	Test Method	Class / Severity	Test Result
Performance Standard: ETSI EN 301 489-17 V3.2.4 (2020-09)&ETSI EN 301 489-1 V2.2.3 (2019-11)&EN 55032:2015/A11:2020					
Conducted Emission	Mode 1	ETSI EN 301 489-17/7.1.1 ETSI EN 301 489-1/8.4	EN 55032:2015/A11:2020annex A.3	Table A.10 Class B	Note ²⁾
Asymmetric mode conducted emissions	/	ETSI EN 301 489-17/7.1.1 ETSI EN 301 489-1/8.7	EN 55032:2015/A11:2020annex A.3	/	Note ²⁾
Radiated Emission	Mode 1	ETSI EN 301 489-17/7.1.1 ETSI EN 301 489-1/8.2	EN 55032:2015/A11:2020Table A.4 and A.5	Table A.4 Class B Table A.5 Class B	PASS
Harmonic current	Mode 1	ETSI EN 301 489-17/7.1.1 ETSI EN 301 489-1/8.5	EN 61000-3-2:2019	Class A	Note ¹⁾
Voltage fluctuations and flicker	Mode 1	ETSI EN 301 489-17/7.1.1 ETSI EN 301 489-1/8.6	EN 61000-3-3:2013/A1:2019	/	Note ²⁾

Immunity

Test Item	Test mode	Equipment test requirement	Test Method	Class / Severity	Test Result
Performance Standard: ETSI EN 301 489-17 V3.2.4 (2020-09)&ETSI EN 301 489-1 V2.2.3 (2019-11)&EN 55035:2017/A11:2020					
Electrostatic discharge (ESD)	Mode 1	ETSI EN 301 489-17/7.2.1 ETSI EN 301 489-1/9.3 EN 55035:2017 Table 1	EN 61000-4-2:2009	Test specification: ±8kV air discharge ±4kV Contact discharge Performance : Criteria B	PASS
RF electromagnetic field (RS)	Mode 1	ETSI EN 301 489-17/7.2.1 ETSI EN 301 489-1/9.2	EN61000-4-3:2006+A1: 2008+A2:2010	Test specification: Test level: For the frequency range 80MHz to 6000MHz, test level shall be 3 V/m, 80% AM(1kHz) Performance: Criteria A	PASS
RF electromagnetic field (RS)	Mode 1	EN 55035:2017 Table 1	IEC 61000-4-3:2006+A1: 2008+A2:2010	Test specification: For the frequency range 80MHz to 1000MHz, 1800MHz, 2600MHz, 3500MHz, 5000MHz test level shall be 3 V/m, 80% AM(1kHz) Performance: Criteria A	PASS
Power frequency magnetic field	Mode 1	EN 55035:2017	IEC 61000-4-8:2009	1A/m 50Hz&60Hz Performance Criterion A	PASS

Note ¹⁾: The EUT with a rated power of less 75 W, the result no judgment.

²⁾: Without AC power port and telecom port of the EUT.

2. GENERAL DESCRIPTION OF EUT

2.1 APPLICANT

Name: Lumi United Technology Co., Ltd.
Room 801-804, Building 1, Chongwen Park, Nanshan iPark, No. 3370, Liuxian
Address: Avenue, Fuguang Community, Taoyuan Residential District, Nanshan District,
Shenzhen, China

2.2 MANUFACTURER

Name: Lumi United Technology Co., Ltd.
Room 801-804, Building 1, Chongwen Park, Nanshan iPark, No. 3370, Liuxian
Address: Avenue, Fuguang Community, Taoyuan Residential District, Nanshan District,
Shenzhen, China

2.3 BASIC DESCRIPTION OF EQUIPMENT UNDER TEST

Product Name: Cube T1 Pro
Product Model: CTP-R01
Adding Model: /
Trade Name: Aqara
Power Supply: Button batteries: CR2450 DC 3V, 3mA
Frequency Band: 2405MHz-2475MHz
Modulation Type: OQPSK
Antenna Type: Internal antenna
Hardware Version: X1.0
Software Version: 0.0.0_0023
Sample submitting way: Provided by customer Sampling
Sample No: E20220414157601-0001
Note: /

2.4 TEST MODE

Mode No.	Description of the modes
1	After connecting with APP, gateway associates EUT in sub-device options, and then monitors EUT movement feedback information in EUT device log.

2.5 LOCAL SUPPORTIVE INSTRUMENTS

Name of Equipment	Manufacturer	Model	Serial Number	Note
Router	Mercury	D128G	1193219002978	/
Phone	Vivo	Vivo Y85	SZDC-2020-059	/
Gateway	Aqara	ZHWG19LM	A00033/5H1AUW10003	/
adapter	Aohai	A70-050200U-EU1	/	Unshielded 1.2m

2.6 CONFIGURATION OF SYSTEM UNDER TEST

Model 1

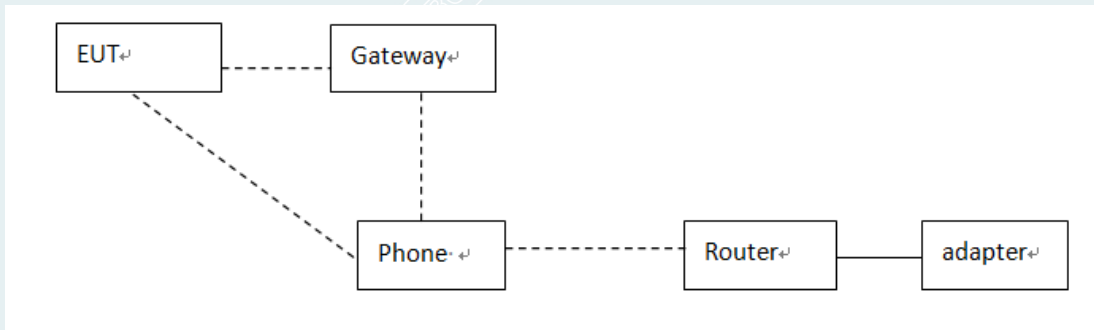

3. LABORATORY AND ACCREDITATIONS

3.1 LABORATORY

The tests & measurements refer to this report were performed by Shenzhen EMC Laboratory of Guangzhou GRG Metrology & Test Co., Ltd.

Add.: No.1301 Guanguang Road Xinlan Community, Guanlan Street, Longhua District
Shenzhen, 518110, People's Republic of China.

P.C.: 518000

Tel : 0755-61180008

Fax: 0755-61180008

3.2 ACCREDITATIONS

Our laboratories are accredited and approved by the following approval agencies according to ISO/IEC 17025.

USA A2LA(Certificate#:2861.01)

China CNAS(L0446)

The measuring facility of laboratories has been authorized or registered by the following approval agencies.

Canada ISED (Company Number: 24897, CAB identifier:CN0069)

USA FCC (Registration Number: 759402, Designation Number:CN1198)

Copies of granted accreditation certificates are available for downloading from our web site,
<http://www.grgtest.com>

----- The following blanks -----

3.3 MEASUREMENT UNCERTAINTY

Where relevant, the following measurement uncertainty levels have been estimated for tests performed on the EUT as specified in CISPR 16-4-2:

Measurement	Frequency	Uncertainty
Conduction Emission	9 kHz~150 kHz	2.2 dB
	150 kHz~30 MHz	2.8 dB
Radiated Emission (3m)	30MHz~200MHz(H)	4.3 dB
	200MHz~1000MHz(H)	4.5 dB
	30MHz~200MHz(V)	4.4 dB
	200MHz~1000MHz(V)	4.5 dB
	1GHz~6GHz(H)	4.5 dB
	1GHz~6GHz(V)	4.5 dB
Harmonic Current	/	1)
Voltage Fluctuation and Flicks	/	1)
Electrostatic discharge	/	1)
Radio-Frequency Electromagnetic Field	/	1)
Electrical fast transient/burst	/	1)
Surge	/	1)
Conducted radio frequency disturbances	/	1)
Power frequency magnetic field	/	1)
Voltage Dip & Voltage Interruptions	/	1)

1) This uncertainty represents an expanded uncertainty factor of $k=2$.

----- The following blanks -----

4. LIST OF USED TEST EQUIPMENT AT GRGT

4.1 LIST OF USED TEST EQUIPMENT

Name of Equipment	Manufacturer	Model	Serial Number	Calibration Due
Radiated Emission (Below 1GHz)				
Test S/W	EZ	CCS-2ANT	/	/
Test Receiver	R&S	ESCI	100145	2022-11-13
Preamplifier	EMEC	EM330	/	2023-03-05
Bi-log Antenna	TESEQ	CBL6143A	32399	2022-11-25
Radiated Emission (Above 1GHz)				
Test software	Tonscend	JS32-RE	/	/
Spectrum Analyzer	Agilent	N9020B	MY57120179	2022-08-08
Preamplifiers	Tonscend	TAP01018048	AP20E8060075	2022-05-09
Horn antenna	Schwarzbeck	BBHA 9120D	02143	2022-10-22
Electrostatic discharge				
Dito ESD Simulator	EM Test	dito	V0809103493	2022-10-30
Radio-Frequency Electromagnetic Field				
Test S/W	Tonscend	JS35-RS	/	/
Signal generator	R&S	SMA100A	100434	2022-09-04
Switch	TOYO	BS5000	/	/
Power Amplifier	SCHAFFNER	CBA9433	3007	2022-10-29
Power Amplifier	TESEQ	CBA 3G-050	T44161	2023-04-06
Power Amplifier	Milmega	AS1860-50	1079232	2022-10-29
Dual directional Coupler	AR	DC 6180A	0328212	2022-09-22
Dual directional Coupler	AR	DC 7144A	327057	2022-09-22
Log-periodic broadband antenna	Schaffner	CBL6143	5082	2023-01-08
Microwave Log.-Per. Antenna	Schwarzbeck	STLP9149	9149-163	2022-09-18
Power Meter	Keysight	N1914A	MY57090009	2022-10-11
Power Probe	Keysight	E9301A	MY57060008	2022-09-04

Power frequency magnetic field				
Test S/W	TESEQ	Win2120 Ver6.00	/	/
Power Source	SCHAFFNER	NSG1007	54789	2023-03-08
Harmonic & Flicker Tester	SCHAFFNER	CCN1000	72045	2022-09-10
Induction coil Interface	SCHAFFNER	INA2141	6003	2022-09-08
Induction coil Interface	SCHAFFNER	INA-702	711-1115	2022-09-08

----- The following blanks -----

5. EMISSION TEST

5.1 RADIATED EMISSION MEASUREMENT (RE)

Test Requirement: ETSI EN 301 489-17 V3.2.4/7.1.1
 ETSI EN 301 489-1 V2.2.3/8.2
 EN55032:2015/A11:2020

Test Method: EN 55032 /annex A.2

5.1.1 LIMITS

The ancillary equipment shall meet the class B limits given in CENELEC EN 55032 [1], annex A tables A.4 and A.5.

**Table A.4 – Requirements for radiated emissions at frequencies up to 1 GHz
 for class B equipment**

Frequency range(MHz)	Distance (m)	Bandwidth	Limits (dBuV/m)		
			Peak (PK)	Quasi-peak (QP)	Average (Avg)
30 to 230	10	120 kHz	/	30	/
230 to 1000	10	120 kHz	/	37	/

**Table A.5 – Requirements for radiated emissions at frequencies above 1 GHz
 for class B equipment**

Frequency range(MHz)	Distance (m)	Bandwidth	Limits (dBuV/m)		
			Peak (PK)	Quasi-peak (QP)	Average (Avg)
1000~3000	3	1MHz	70	/	50
3000~6000	3	1MHz	74	/	54

----- The following blanks -----

5.1.2 TEST PROCEDURE

(1) Procedure of Preliminary Test

Radiated emission tests shall be made with the receive or transmit antenna located at a horizontal distance of 3m or 10m plus half of the maximum width of the EUT being tested, measured from the centre of the EUT. The tests shall be performed with the equipment configured as closely as possible to its typical, practical operation. Unless stated otherwise, cables and wiring shall be as specified by the manufacturer and the equipment shall be in its housing (or cabinet) with all covers and access panels in place. Any deviation from normal EUT operating conditions shall be included in the test report.

The EUT (on a non-conductive support structure, where applicable) shall be placed on a remotely operated turntable, to allow the EUT to be rotated. The height of the EUT above the ground plane shall be according to the following requirements.

-- Table-top equipment is placed on a non-conductive set-up table with height $0.8\text{ m} \pm 0.01\text{ m}$, CISPR 16-1-4 specifies the method to determine the impact of the non-conductive set-up table on test results.

-- Floor-standing equipment is placed on a non-conductive support, as specified in the applicable product standard. If there are no EUT height placement requirements in the product standard, the EUT shall be placed on a non-conductive support at a height of 5 cm to 15 cm above the ground plane.

Note: This is table-top equipment.

Interface cables, loads, and devices should be connected to at least one of each type of the interface ports of the EUT and, where practical, each cable shall be terminated in a device typical for its actual use. Where there are multiple interface ports of the same type, a typical number of these devices shall be connected to devices or loads. It is sufficient to connect only one of the loads, provided that it can be shown, for example by preliminary testing, that the connection of further ports would not significantly increase the level of disturbance (that is, more than 2 dB) or significantly degrade the immunity level.

The test mode(s) were scanned during the preliminary test. After the preliminary scan, we found the test mode producing the highest emission level. The EUT and cable configuration, antenna position, polarization and turntable position of the above highest emission level were recorded for the final test.

(2) Procedure of Final Test

EUT and support equipment were set up on the turntable as per the configuration with highest emission level in the preliminary test. The Analyzer/ Receiver scanned from 30MHz to 1000MHz and 1000MHz to 6000MHz. Emissions were scanned and measured rotating the EUT to 360 degrees, varying cable placement and positioning the antenna 1 to 4 meters above the ground plane, in both the vertical and the horizontal polarization, to maximize the emission reading level. Record at least six highest emissions. Emission frequency, amplitude, antenna position, polarization and turntable position were recorded into a computer in which correction factors were used to calculate the emission level and compare reading to the applicable limit and for 30MHz~1000MHz only QP reading is presented, for 1000MHz~6000 MHz Peak and AVG reading is presented.

5.1.3 TEST SETUP

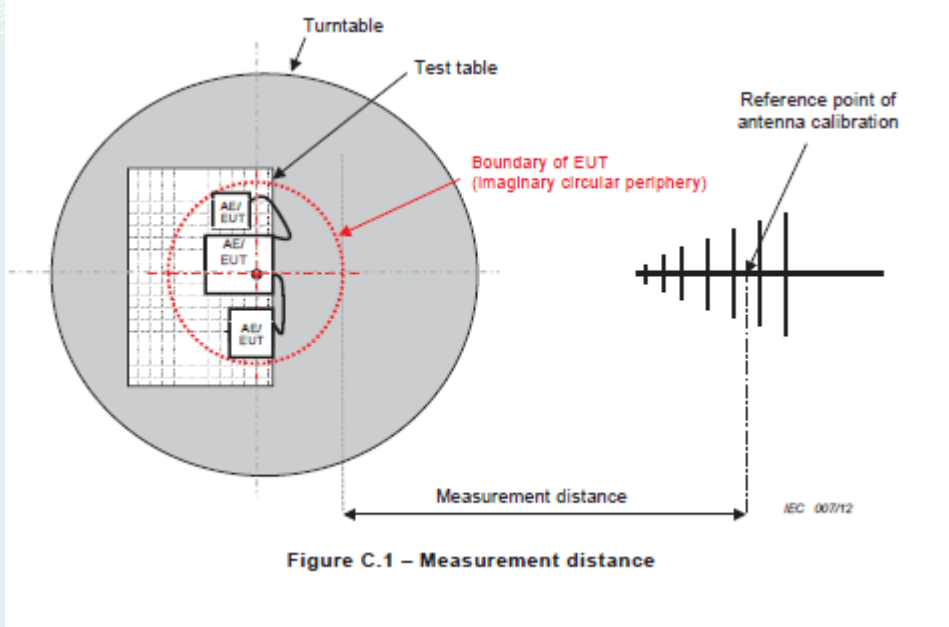

Below the frequency of 1GHz

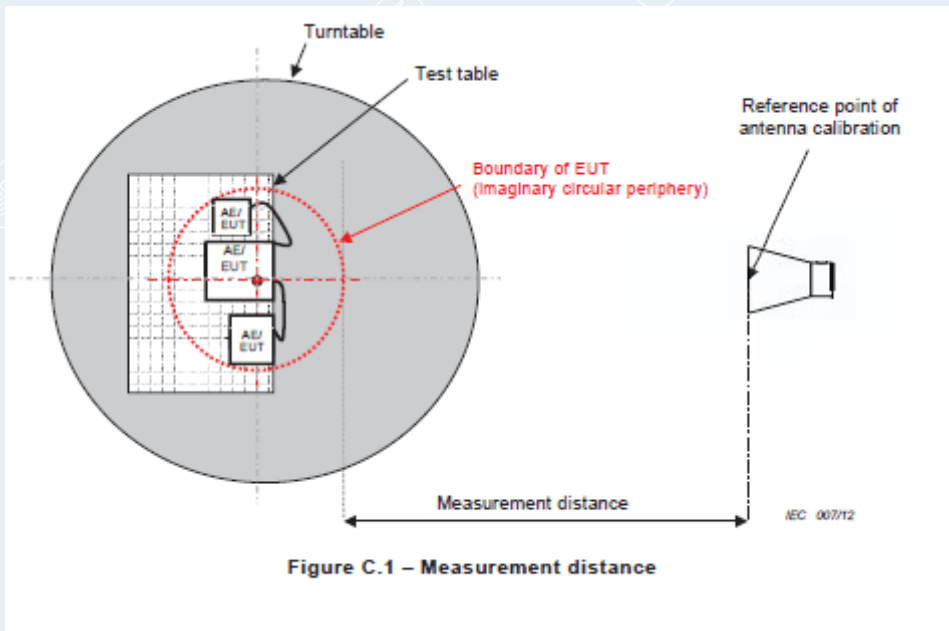

Above the frequency of 1GHz(1GHz-6GHz)

5.1.4 DATA SAMPLE

Below 1GHz

Frequency (MHz)	Reading (dBuV)	Correct Factor (dB/m)	Result (dBuV/m)	Limit (dBuV/m)	Over (dB)	Remark
XXX.XXXX	37.90	-22.89	15.01	37.00	-21.99	QP

- Frequency (MHz) = Emission frequency in MHz
- Reading (dBuV) = Uncorrected Analyzer / Receiver reading
- Correct Factor (dB/m) = Antenna factor + Cable loss – Amplifier gain
- Result (dBuV/m) = Reading (dBuV) + Corr. Factor (dB/m)
- Limit (dBuV/m) = Limit stated in standard
- Over (dB) = Result (dBuV/m) – Limit(dBuV/m)
- QP = Quasi-peak Reading

Above 1GHz

Frequency (MHz)	Reading (dBuV)	Level (dBuV/m)	Factor (dB)	Limit (dBuV/m)	Margin (dB)	Remark
XXXX	56.70	34.18	-22.52	74	39.82	Peak
XXXX	46.34	23.80	-22.54	54	30.20	AVG

- Frequency (MHz) = Emission frequency in MHz
- Reading (dBuV) = Uncorrected Analyzer / Receiver reading
- Correction Factor (dB/m) = Antenna factor + Cable loss – Amplifier gain
- Result (dBuV/m) = Reading (dBuV) + Correction Factor (dB/m)
- Limit (dBuV/m) = Limit stated in standard
- Margin (dB) =Limit(dBuV/m)- Level(dBuV/m)
- Peak = Peak Reading
- AVG = Average Reading

5.1.5 PHOTOGRAPH OF THE TEST ARRANGEMENT



Below 1GHz

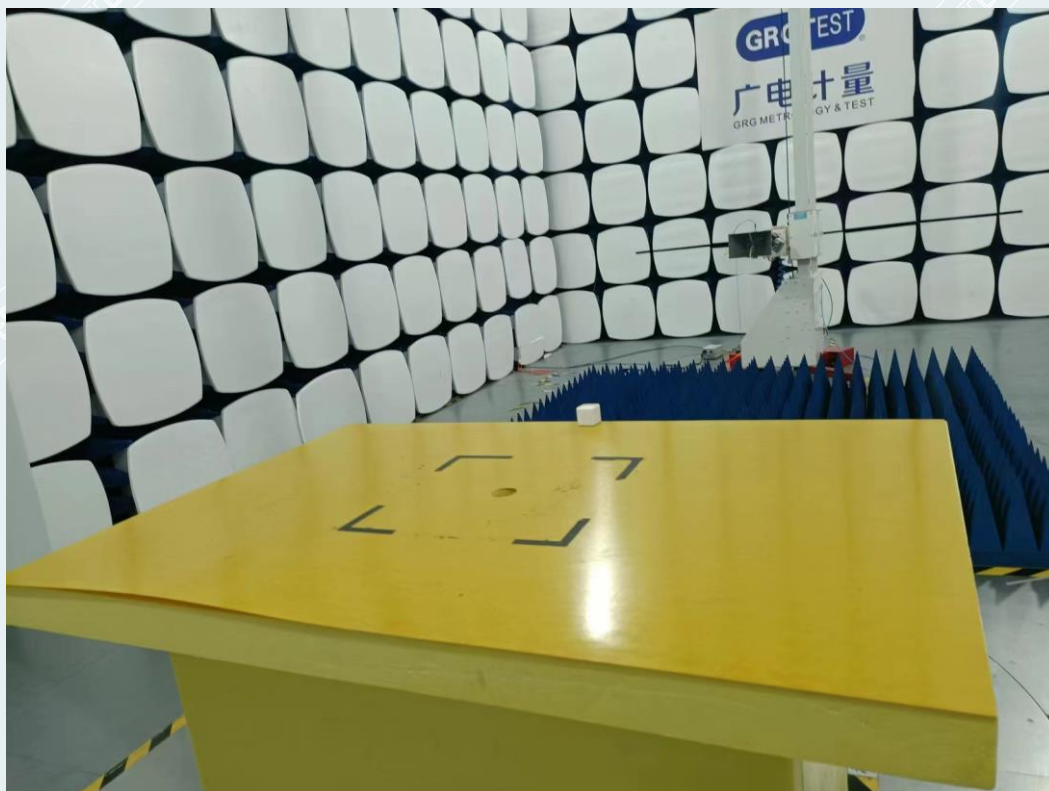

Above 1GHz

5.1.6 TEST RESULTS

Below 1GHz

EUT Name	Cube T1 Pro	Model	CTP-R01
Environmental Conditions	23.5°C/47%RH/101.0kPa	Test Mode	Mode 1
Power supply	DC 3V	Tested By	Zeng Xianglong
Test Date	2022-04-26	Sample No.	E20220414157601-0001

Polarity: Horizontal

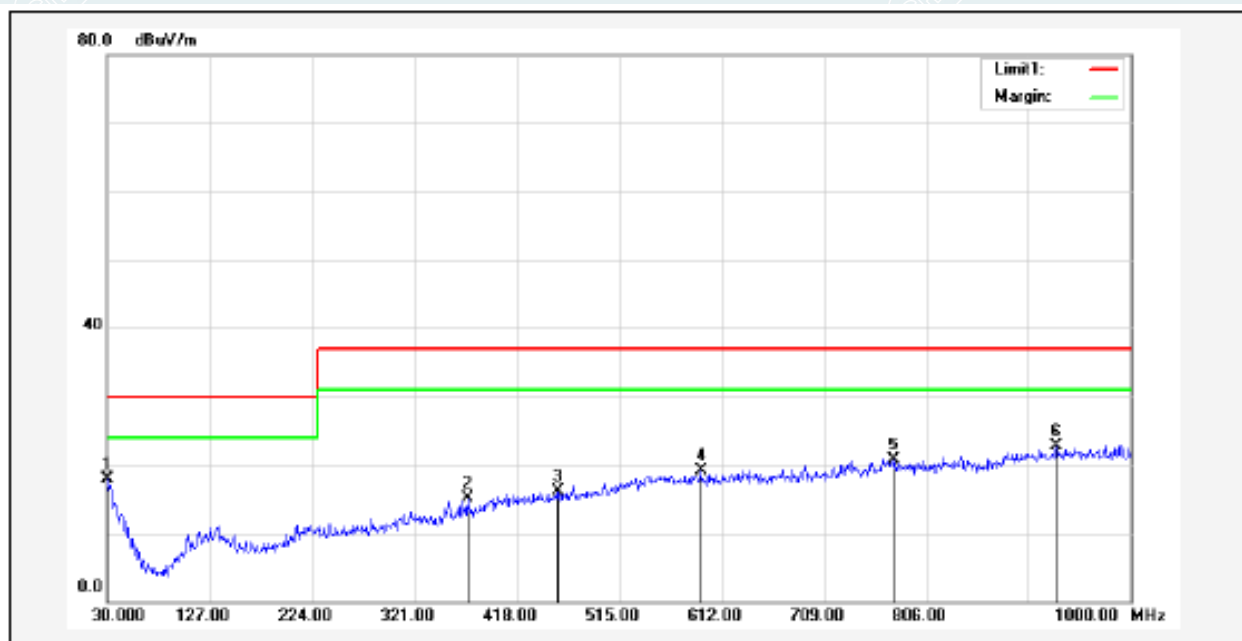

No.	Frequency (MHz)	Reading (dBuV)	Correction factor(dB/m)	Result (dBuV/m)	Limit (dBuV/m)	Over (dB)	Degree (deg.)	Height (cm)	Remark
1*	30.0000	34.75	-16.91	17.84	30.00	-12.16	75	199	QP
2	371.4400	37.90	-22.89	15.01	37.00	-21.99	0	318	QP
3	456.8000	36.97	-20.90	16.07	37.00	-20.93	283	299	QP
4	592.8000	37.34	-18.21	19.13	37.00	-17.87	0	178	QP
5	774.9600	37.18	-16.46	20.70	37.00	-16.30	281	309	QP
6	929.1900	38.34	-15.55	22.79	37.00	-14.21	0	137	QP

EUT Name	Cube T1 Pro	Model	CTP-R01
Environmental Conditions	23.5°C/47%RH/101.0kPa	Test Mode	Mode 1
Power supply	DC 3V	Tested By	Zeng Xianglong
Test Date	2022-04-26	Sample No.	E20220414157601-0001

Polarity: Vertical

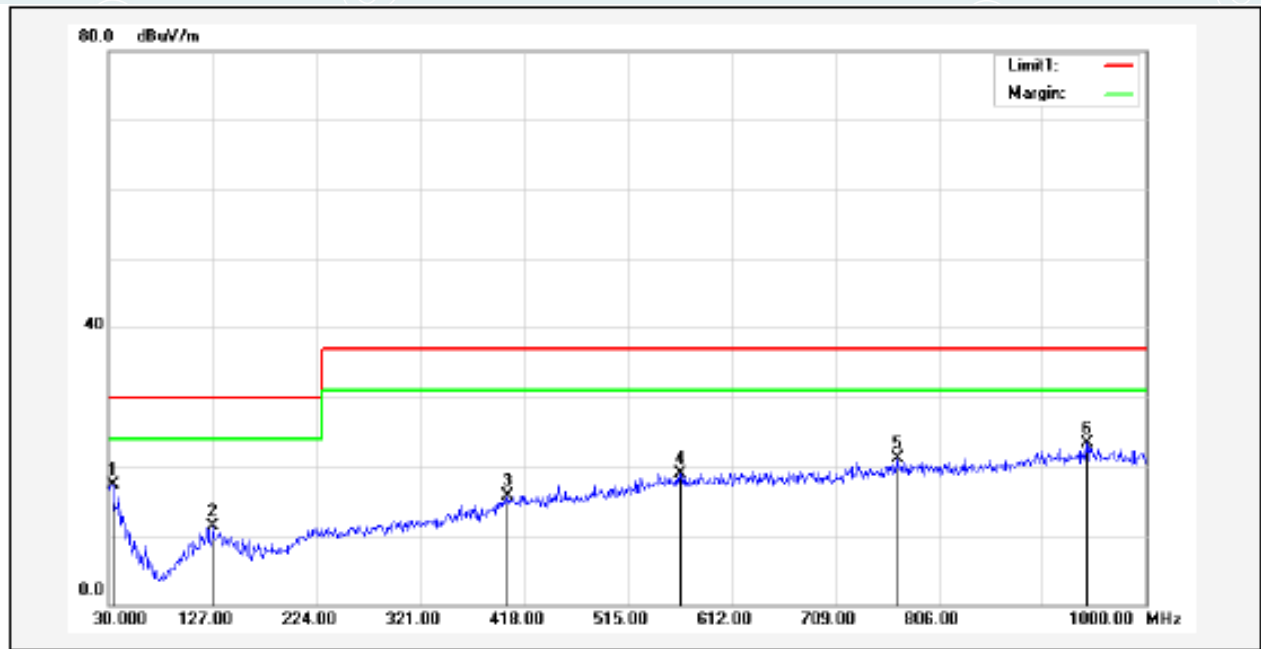

No.	Frequency (MHz)	Reading (dBuV)	Correction factor(dB/m)	Result (dBuV/m)	Limit (dBuV/m)	Over (dB)	Degree (deg.)	Height (cm)	Remark
1*	33.8800	36.12	-18.82	17.30	30.00	-12.70	323	399	QP
2	127.9700	37.67	-26.35	11.32	30.00	-18.68	85	300	QP
3	403.4500	37.14	-21.43	15.71	37.00	-21.29	294	200	QP
4	564.4700	37.31	-18.34	18.97	37.00	-18.03	158	300	QP
5	787.2000	37.57	-16.54	21.03	37.00	-15.97	0	355	QP
6	944.7100	38.74	-15.53	23.21	37.00	-13.79	359	298	QP

Above 1GHz

EUT Name	Cube T1 Pro	Model	CTP-R01
Environmental Conditions	24.8°C/52%RH/101.0kPa	Test Mode	Mode 1
Power supply	DC 3V	Tested By	Lu Qiang
Test Date	2022-05-05	Sample No.	E20220414157601-0001

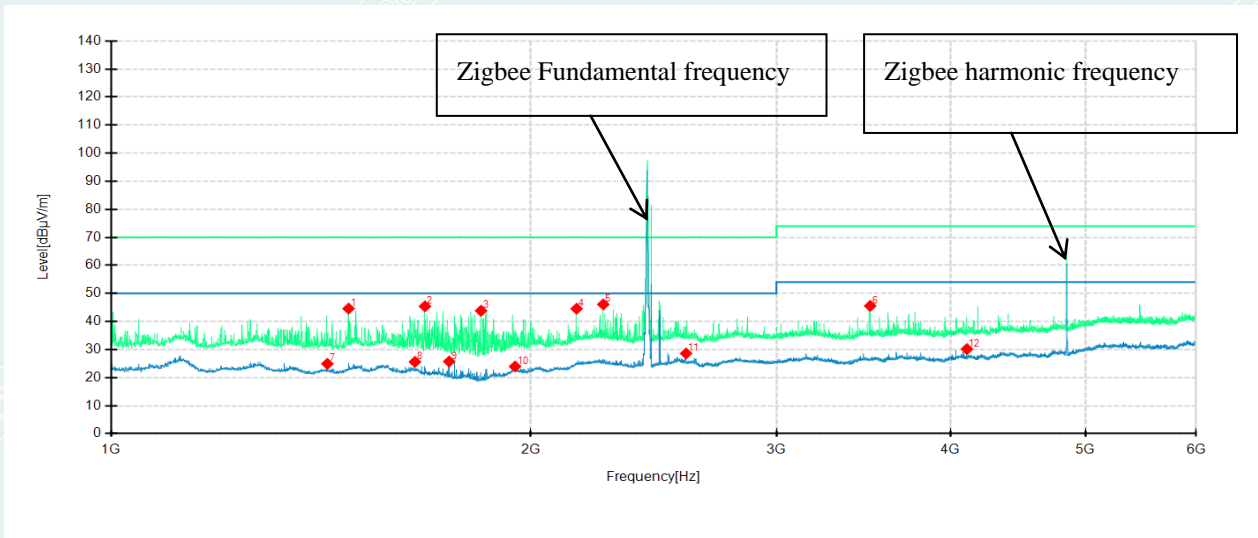

Suspected Data List									
NO.	Freq. [MHz]	Reading [dBµV/m]	Level [dBµV/m]	Factor [dB]	Limit [dBµV/m]	Margin [dB]	Height [cm]	Angle [°]	Polarity
1	1480	67.70	44.59	-23.11	70.00	25.41	100	115	Horizontal
2	1679	68.77	45.40	-23.37	70.00	24.60	100	158	Horizontal
3	1842	66.23	43.83	-22.40	70.00	26.17	100	87	Horizontal
4	2157	64.67	44.55	-20.12	70.00	25.45	100	265	Horizontal
5	2254	65.21	46.07	-19.14	70.00	23.93	100	356	Horizontal
6	3503	62.45	45.56	-16.89	74.00	28.44	100	205	Horizontal
7	1429	48.50	24.91	-23.59	50.00	25.09	100	320	Horizontal
8	1651.5	48.79	25.59	-23.20	50.00	24.41	100	200	Horizontal
9	1747.5	49.29	25.74	-23.55	50.00	24.26	100	177	Horizontal
10	1948.5	45.19	23.94	-21.25	50.00	26.06	100	111	Horizontal
11	2584.5	47.59	28.60	-18.99	50.00	21.40	100	134	Horizontal
12	4110	45.55	30.16	-15.39	54.00	23.84	100	289	Horizontal

EUT Name	Cube T1 Pro	Model	CTP-R01
Environmental Conditions	24.8°C/52%RH/101.0kPa	Test Mode	Mode 1
Power supply	DC 3V	Tested By	Lu Qiang
Test Date	2022-05-05	Sample No.	E20220414157601-0001

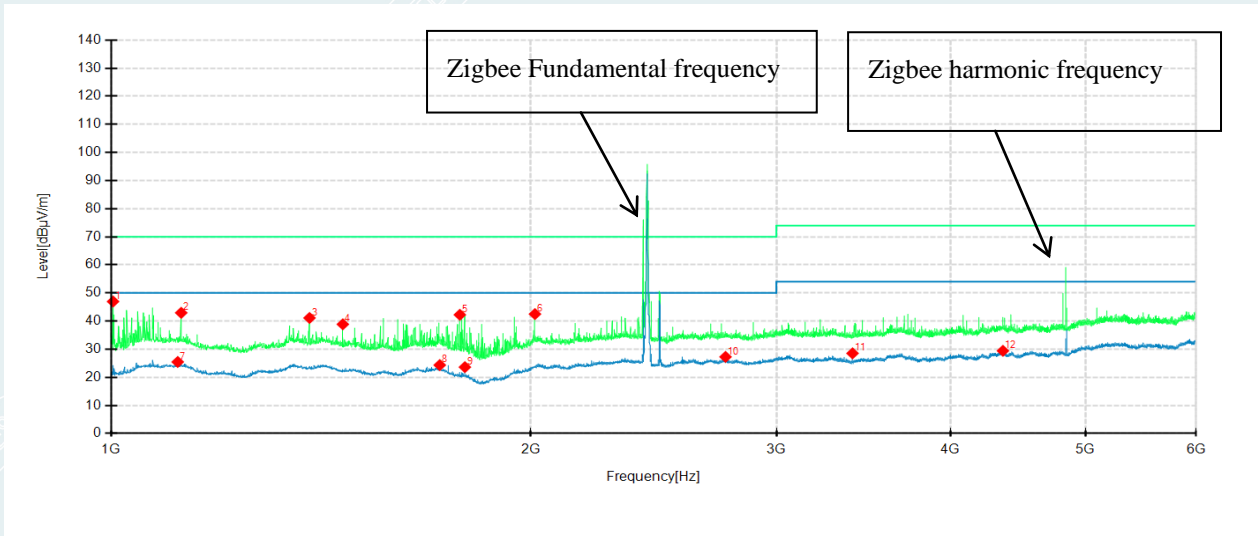

Suspected Data List									
NO.	Freq. [MHz]	Reading [dBµV/m]	Level [dBµV/m]	Factor [dB]	Limit [dBµV/m]	Margin [dB]	Height [cm]	Angle [°]	Polarity
1	1003	72.58	46.96	-25.62	70.00	23.04	100	267	Vertical
2	1122.5	65.86	42.94	-22.92	70.00	27.06	200	59	Vertical
3	1387.5	62.94	41.12	-21.82	70.00	28.88	200	116	Vertical
4	1466	61.60	38.85	-22.75	70.00	31.15	200	6	Vertical
5	1778.5	64.85	42.24	-22.61	70.00	27.76	200	170	Vertical
6	2013.5	63.10	42.50	-20.60	70.00	27.50	100	143	Vertical
7	1116	48.09	25.45	-22.64	50.00	24.55	200	235	Vertical
8	1720.5	46.54	24.34	-22.20	50.00	25.66	200	230	Vertical
9	1793.5	46.37	23.62	-22.75	50.00	26.38	200	164	Vertical
10	2758.5	45.80	27.25	-18.55	50.00	22.75	100	57	Vertical
11	3402.5	46.72	28.52	-18.20	54.00	25.48	100	290	Vertical
12	4362	43.42	29.41	-14.01	54.00	24.59	200	249	Vertical

Remark: The fundamental frequency or multiple of fundamental frequency's limit is controlled to the standard of Radio frequency.

6. IMMUNITY TEST

6.1 GENERAL DESCRIPTION

EMC Immunity					
ETSI EN 301 489-17 V3.2.4&ETSI EN 301 489-1 V2.2.3&EN 55035:2017/A11:2020					
Item	Application port	Basic Standard	Test method	Performance Criterion	Result
Electrostatic discharge (ESD)	Enclosure port	ETSI EN 301 489-17 V3.2.4 /7.2.1 ETSI EN 301 489-1 V2.2.3/9.3 EN 55035:2017 Table 1	EN 61000-4-2	Test specification: ±8kV air discharge ±4kV Contact discharge Performance : Criteria B	PASS
Radiated radio-frequency electromagnetic (RS)	Enclosure port	ETSI EN 301 489-1 V2.2.3/9.2 ETSI EN 301 489-17 V3.2.4 /7.2.1	EN 61000-4-3	Test specification: Test level: For the frequency range 80MHz to 6000MHz, test level shall be 3 V/m, 80% AM(1kHz) Performance: Criteria A	PASS
Radiated radio-frequency electromagnetic (RS)	Enclosure port	EN 55035:2017 Table 1	IEC 61000-4-3	Test specification: Test level: For the frequency range 80MHz to 1000MHz, 1800MHz, 2600MHz, 3500MHz, 5000MHz test level shall be 3 V/m, 80% AM(1kHz) Performance: Criteria A	PASS
Power frequency magnetic field(PFMF)	Enclosure ports	EN 55035:2017 Table 1	IEC 61000-4-8	1A/m 50Hz&60Hz Performance Criterion A	PASS

6.2 GENERAL PERFORMANCE CRITERIA DESCRIPTION (ETSI EN 301 489-1/17)

6.2.1 GENERAL PERFORMANCE CRITERIA

The performance criteria are:

- Performance criteria A for immunity tests with phenomena of a continuous nature;
- Performance criteria B for immunity tests with phenomena of a transient nature;
- Performance criteria C for immunity tests with power interruptions exceeding a certain time.

The equipment shall meet the minimum performance criteria as specified in the following clauses.

Performance table

Criteria	During Test	After test (i.e. as a result of the application of the test)
A	Shall operate as intended. (See note). Shall be no loss of function. Shall be no unintentional transmissions.	Shall operate as intended. Shall be no degradation of performance. Shall be no loss of function. Shall be no loss of critical stored data.
B	May be loss of function.	Functions shall be self-recoverable. Shall operate as intended after recovering. Shall be no loss of critical stored data.
C	May be loss of function.	Functions shall be recoverable by the operator. Shall operate as intended after recovering. Shall be no loss of critical stored data.

NOTE: Operate as intended during the test allows a level of degradation in accordance with clause 6.2.2.

Performance Criteria	Description
Performance criteria for continuous phenomena applied to transmitters and receivers	If no further details are given in the relevant part of EN 301 489 series [i.13] dealing with the particular type of radio equipment, the following general performance criteria for continuous phenomena shall apply. During and after the test, the apparatus shall continue to operate as intended. No degradation of performance or loss of function is allowed below a permissible performance level specified by the manufacturer when the apparatus is used as intended. In some cases this permissible performance level may be replaced by a permissible loss of performance. During the test the EUT shall not unintentionally transmit or change its actual operating state and stored data. If the minimum performance level or the permissible performance loss is not specified by the manufacturer, then either of these may be deduced from the product description and documentation and what the user may reasonably expect from the apparatus if used as intended.
Performance criteria for transient phenomena applied to transmitters and receivers	If no further details are given in the relevant part of EN 301 489 series [i.13] dealing with the particular type of radio equipment, the following general performance criteria for transient phenomena shall apply. For surges applied to symmetrically operated wired network ports intended to be connected directly to outdoor lines the following criteria applies: <ul style="list-style-type: none"> • For products with only one symmetrical port intended for connection to outdoor lines, loss of function is allowed, provided the function is self-recoverable, or can be restored by the operation of the controls by the user in accordance with the manufacturer's instructions. A SW reboot is not allowed.

	<p>Information stored in non-volatile memory, or protected by a battery backup, shall not be lost.</p> <ul style="list-style-type: none"> • For products with more than one symmetrical port intended for connection to outdoor lines, loss of function on the port under test is allowed, provided the function is self-recoverable. A SW reboot is not allowed. Information stored in non-volatile memory, or protected by a battery backup, shall not be lost. <p>For all other ports the following applies:</p> <ul style="list-style-type: none"> • After the test, the equipment shall continue to operate as intended. No degradation of performance or loss of function is allowed below a permissible performance level specified by the manufacturer, when the equipment is used as intended. In some cases this permissible performance level may be replaced by a permissible loss of performance. • During the EMC exposure to an electromagnetic phenomenon, a degradation of performance is, however, allowed. No change of the actual mode of operation (e.g. unintended transmission) or stored data is allowed. • If the minimum performance level or the permissible performance loss is not specified by the manufacturer, then either of these may be deduced from the product description and documentation and what the user may reasonably expect from the equipment if used as intended.
<p>Performance criteria for equipment which does not provide a continuous communication link</p>	<p>For radio equipment which does not provide a continuous communication link, the performance criteria described in clauses 6.1 and 6.2 are not appropriate, in these cases the manufacturer shall declare, for inclusion in the test report, his own specification for an acceptable level of performance or degradation of performance during and/or after the immunity tests. The performance specification shall be included in the product description and documentation. The related specifications set out in clause 5.3 have also to be taken into account. The performance criteria specified by the manufacturer shall give the same degree of immunity protection as called for in clauses 6.1 and 6.2.</p>
<p>Performance criteria for ancillary equipment tested on a stand alone basis</p>	<p>If ancillary equipment is intended to be tested on a stand alone basis, the performance criteria described in clauses 6.1 and 6.2 are not appropriate, in these cases the manufacturer shall declare, for inclusion in the test report, his own specification for an acceptable level of performance or degradation of performance during and/or after the immunity tests. The performance specification shall be included in the product description and documentation. The related specifications set out in clause 5.3 have also to be taken into account. The performance criteria specified by the manufacturer shall give the same degree of immunity protection as called for in clauses 6.1 and 6.2.</p>

Performance Criteria	Description
CT	The performance criteria A shall apply. Tests shall be repeated with the EUT in standby mode (if applicable) to ensure that unintentional transmission does not occur. In systems using acknowledgement signals, it is recognized that an ACKnowledgement (ACK) or Not ACKnowledgement (NACK) transmission may occur, and steps should be taken to ensure that any transmission resulting from the application of the test is correctly interpreted.
TT	The performance criteria B shall apply, except for voltage dips of 100 ms and voltage interruptions of 5 000 ms duration, for which performance criteria C shall apply. Tests shall be repeated with the EUT in standby mode (if applicable) to ensure that unintentional transmission does not occur. In systems using acknowledgement signals, it is recognized that an acknowledgement (ACK) or not-acknowledgement (NACK) transmission may occur, and steps should be taken to ensure that any transmission resulting from the application of the test is correctly interpreted.
CR	The performance criteria A shall apply. Where the EUT is a transceiver, under no circumstances, shall the transmitter operate unintentionally during the test. In systems using acknowledgement signals, it is recognized that an ACK or NACK transmission may occur, and steps should be taken to ensure that any transmission resulting from the application of the test is correctly interpreted.
TR	The performance criteria B shall apply, except for voltage dips of 100 ms and voltage interruptions of 5 000 ms duration for which performance criteria C shall apply. Where the EUT is a transceiver, under no circumstances, shall the transmitter operate unintentionally during the test. In systems using acknowledgement signals, it is recognized that an ACK or NACK transmission may occur, and steps should be taken to ensure that any transmission resulting from the application of the test is correctly interpreted.

Note:

Criterion A applies for immunity tests with phenomena of a continuous nature. (CT, CR)

Criterion B applies for immunity tests with phenomena of a transient nature. (TT, TR)

Criterion C for immunity tests with power interruptions exceeding a certain time.

6.2.2 MINIMUM PERFORMANCE LEVEL

For equipment that supports a PER or FER, the minimum performance level shall be a PER or FER less than or equal to 10 %.

For equipment that does not support a PER or a FER, the minimum performance level shall be no loss of the wireless transmission function needed for the intended use of the equipment.

6.2.3 PERFORMANCE CRITERIA FOR CONTINUOUS PHENOMENA

The performance criteria A shall apply.

Where the EUT is a transmitter in standby mode, unintentional transmission shall not occur during the test.

Where the EUT is a transceiver in receive mode, unintentional transmission shall not occur during the test.

6.2.4 PERFORMANCE CRITERIA FOR TRANSIENT PHENOMENA

The performance criteria B shall apply, except for voltage dips greater than or equal to 100 ms and voltage interruptions of 5 000 ms duration, for which performance criteria C shall apply.

Where the EUT is a transmitter in standby mode, unintentional transmission shall not occur as a result of the application of the test.

Where the EUT is a transceiver in receive mode, unintentional transmission shall not occur as a result of the application of the test.

----- **The following blanks** -----

6.3 GENERAL PERFORMANCE CRITERIA DESCRIPTION (EN 55035)

6.3.1 GENERAL PERFORMANCE CRITERIA

Performance criterion A

The equipment shall continue to operate as intended without operator intervention. No degradation of performance, loss of function or change of operating state is allowed below a performance level specified by the manufacturer when the equipment is used as intended. The performance level may be replaced by a permissible loss of performance. If the minimum performance level or the permissible performance loss is not specified by the manufacturer, then either of these may be derived from the product description and documentation, and by what the user may reasonably expect from the equipment if used as intended.

Performance criterion B

During the application of the disturbance, degradation of performance is allowed. However, no unintended change of actual operating state or stored data is allowed to persist after the test. After the test, the equipment shall continue to operate as intended without operator intervention; no degradation of performance or loss of function is allowed, below a performance level specified by the manufacturer, when the equipment is used as intended. The performance level may be replaced by a permissible loss of performance.

If the minimum performance level (or the permissible performance loss), or recovery time, is not specified by the manufacturer, then either of these may be derived from the product description and documentation, and by what the user may reasonably expect from the equipment if used as intended.

Performance criterion C

Loss of function is allowed, provided the function is self-recoverable, or can be restored by the operation of the controls by the user in accordance with the manufacturer's instructions. A reboot or re-start operation is allowed. Information stored in non-volatile memory, or protected by a battery backup, shall not be lost.

----- The following blanks -----

6.4 ELECTROSTATIC DISCHARGE(ESD)

6.4.1 TEST SPECIFICATION

Test Requirement:	ETSI EN 301 489-17 V3.2.4 /7.2.1 ETSI EN 301 489-1 V2.2.3/9.3 EN 55035:2017/A11:2020 Table 1
Test Method:	EN 61000-4-2:2009
Discharge Impedance:	330 ohm / 150 pF
Discharge Voltage:	Air Discharge : ± 8 kV; Contact Discharge: ± 4 kV
Polarity:	Positive & Negative
Number of Discharge:	10 times at each test point
Discharge Mode:	Single Discharge 1 second

6.4.2 TEST PROCEDURE

The basic test procedure was in accordance with EN 61000-4-2:

The test generator necessary to perform direct and indirect application of discharges to the EUT in the following manner:

- (1) The test shall be performed with single discharges. On each pre-selected point at least 10 single discharges (in the most sensitive polarity) shall be applied.

NOTE 1 The minimum number of discharges applied is depending on the EUT; for products with synchronized circuits the number of discharges should be larger.

For the time interval between successive single discharges an initial value of 1 s is recommended. Longer intervals may be necessary to determine whether a system failure has occurred.

NOTE 2 The points to which the discharges should be applied may be selected by means of an exploration carried out at a repetition rate of 20 discharges per second, or more.

Vertical Coupling Plane (VCP):

The coupling plane, of dimensions 0.5m x 0.5m, is placed parallel to, and positioned at a distance 0.1m from, the EUT, with the Discharge Electrode touching the coupling plane.

The four faces of the EUT will be performed with electrostatic discharge.

Horizontal Coupling Plane (HCP):

The coupling plane is placed under to the EUT. The generator shall be positioned vertically at a distance of 0.1m from the EUT, with the Discharge Electrode touching the coupling plane.

The four faces of the EUT will be performed with electrostatic discharge.

- (2) Air discharges at insulation surfaces of the EUT.

It was at least ten single discharges with positive and negative at the same selected point.

- (3) For TABLE-TOP equipment:

The configuration consisted of a wooden table 0.8 meters high standing on the Ground Reference Plane. The GRP consisted of a sheet of aluminum at least 0.25mm thick, and 2.5 meters square connected to the protective

grounding system. A Horizontal Coupling Plane (1.6m x 0.8m) was placed on the table and attached to the GRP by means of a cable with 940k total impedance. The equipment under test was installed in a representative system as described in EN 61000-4-2, and its cables were placed on the HCP and isolated by an insulating support of 0.5mm thickness. A distance of 1-meter minimum was provided between the EUT and the walls of the laboratory and any other metallic structure.

6.4.3 TEST SETUP

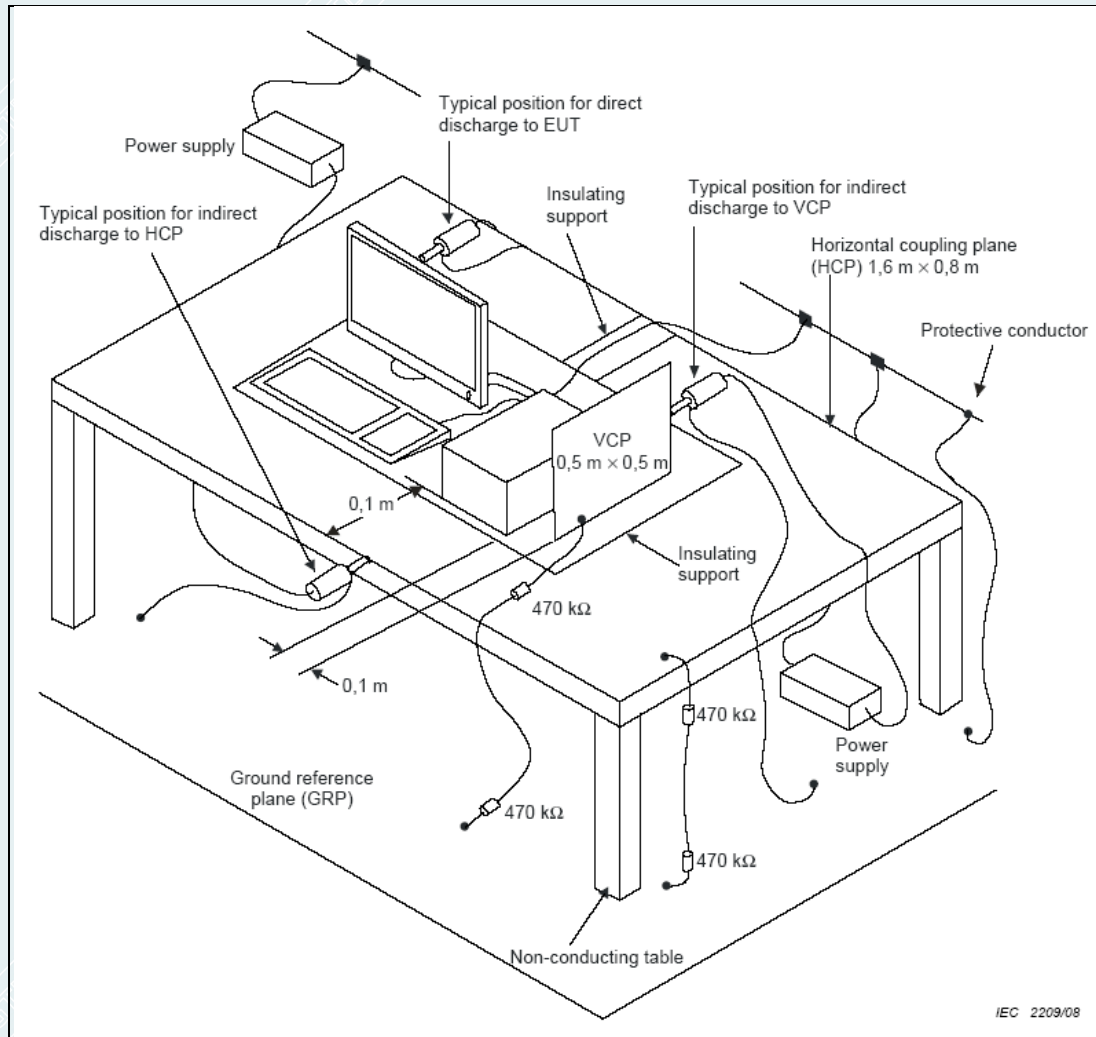

6.4.4 PHOTOGRAPH OF THE TEST ARRANGEMENT

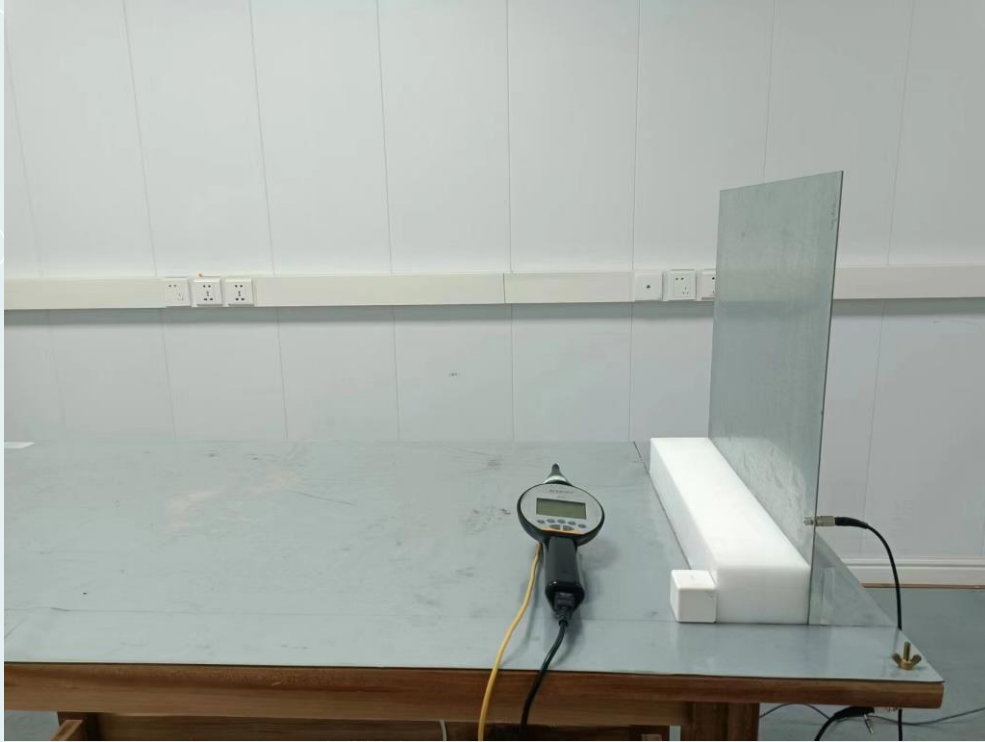

----- The following blanks -----

6.4.5 TEST RESULTS

EUT Name	Cube T1 Pro	Model	CTP-R01
Environmental Conditions	23°C/49%RH/101kPa	Test Mode	Mode 1
Power supply	DC 3V	Tested By	Zhou Wen
Test Date	2022-05-07	Sample No.	E20220414157601-0001

For EN55035:

Discharge point	Discharge voltage	C-Conduct A-Air	Required Performance	Actual performance	Result
Vertical coupling plane	±2kV, ±4kV	C	Criterion B	Criterion A ¹⁾	PASS
Horizontal coupling plane	±2kV, ±4kV	C	Criterion B	Criterion A ¹⁾	PASS
EUT Shell gaps	±2kV, ±4kV, ±8kV	A	Criterion B	Criterion A ¹⁾	PASS
NOTE: ¹⁾ Before test, during the test, and after test, the EUT functions and works are normally. The feedback information in EUT device logs is not interrupted.					

For EN 301489-1/ EN301489-17:

Discharge point	Discharge voltage	C-Conduct A-Air	Required Performance	Actual performance	Result
Vertical coupling plane	±2kV, ±4kV	C	Criterion B	Criterion A ¹⁾	PASS
Horizontal coupling plane	±2kV, ±4kV	C	Criterion B	Criterion A ¹⁾	PASS
EUT Shell gaps	±2kV, ±4kV, ±8kV	A	Criterion B	Criterion A ¹⁾	PASS
NOTE: ¹⁾ Before test, during the test, and after test, the EUT functions and works are normally. The feedback information in EUT device logs is not interrupted.					

6.5 RADIATED RADIO-FREQUENCY ELECTROMAGNETIC FIELD (RS)

6.5.1 TEST SPECIFICATION

Test Requirement:	ETSI EN 301 489-17 V3.2.4 /7.2.1 ETSI EN 301 489-1 V2.2.3/9.2 EN 55035:2017/A11:2020 Table 1
Test Method:	EN 61000-4-3:2006+A1:2008+A2:2010
Frequency Range:	EN 55035: 80MHz~1000MHz,1800MHz, 2600MHz, 3500MHz, 5000MHz ETSI EN 301 489-17& ETSI EN 301 489-1: 80MHz~6000MHz
Field Strength:	3 V/m
Modulation:	1kHz Sine Wave, 80%, AM Modulation
Polarity of Antenna:	Horizontal and Vertical
Test Distance:	3 m
Antenna Height:	1.55m

6.5.2 TEST PROCEDURE

- (1) The testing is performed in a fully anechoic chamber. The transmit antenna was located at a distance of 3 meters from the EUT.
- (2) The frequency range is swept from 80 MHz~6000 MHz, with the signal 80% amplitude modulated with a 1 kHz sine-wave. The rate of sweep did not exceed 1.5×10^{-3} decade/s, where the frequency range is swept incrementally; the step size is 1% of preceding frequency value.
- (3) The dwell time at each frequency shall be not less than the time necessary for the EUT to be able to respond.
- (4) The test is performed with the EUT exposed to both vertically and horizontally polarized fields on each of the four sides.

6.5.3 TEST SETUP

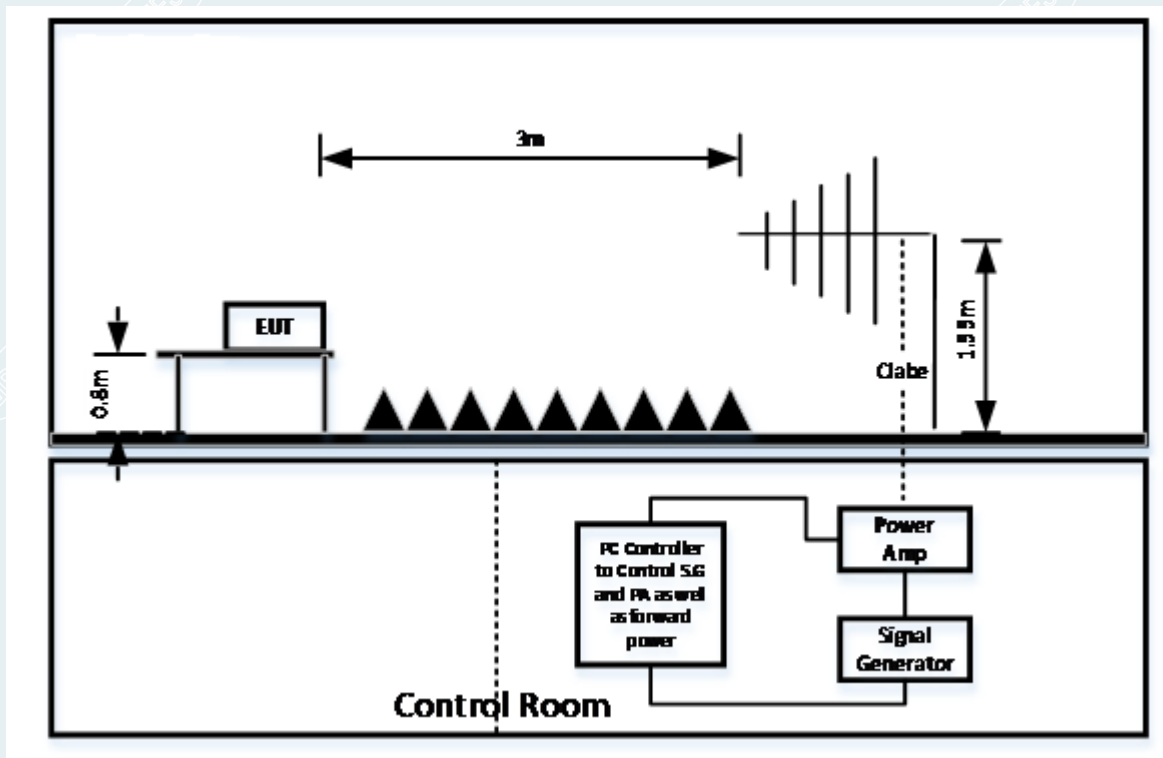

NOTE:

(1) Table-top equipment

The EUT installed in a representative system as described in section 7 of EN 61000-4-3 was placed on a non-conductive table 0.8 meters in height. The system under test was connected to the power and signal wire according to relevant installation instructions.

(2) Floor-standing equipment

The EUT installed in a representative system as described in section 7 of EN 61000-4-3 was placed on a non-conductive wood support 0.1 meters in height. The system under test was connected to the power and signal wire according to relevant installation instructions.

Note: the EUT is a Table-top equipment.

6.5.4 PHOTOGRAPH OF THE TEST ARRANGEMENT



80MHz~1000MHz



1000MHz~6000MHz

6.5.5 TEST RESULTS

EUT Name	Cube T1 Pro	Model	CTP-R01
Environmental Conditions	24°C/51%RH/101kPa	Test Mode	Mode 1
Power supply	DC 3V	Tested By	Zhou Wen
Test Date	2022-05-07	Sample No.	E20220414157601-0001

For EN 55035:

Frequency	Field strength (V/m)	EUT orientation	Antenna polarization	Required criterion	Actual performance	Result
80MHz~1000MHz	3	Front	H	Criterion A	Criterion A ¹⁾	pass
			V	Criterion A	Criterion A ¹⁾	pass
		Left	H	Criterion A	Criterion A ¹⁾	pass
			V	Criterion A	Criterion A ¹⁾	pass
		Right	H	Criterion A	Criterion A ¹⁾	pass
			V	Criterion A	Criterion A ¹⁾	pass
1800MHz,2600MHz,3500MHz,5000MHz	3	Front	H	Criterion A	Criterion A ¹⁾	pass
			V	Criterion A	Criterion A ¹⁾	pass
		Left	H	Criterion A	Criterion A ¹⁾	pass
			V	Criterion A	Criterion A ¹⁾	pass
		Right	H	Criterion A	Criterion A ¹⁾	pass
			V	Criterion A	Criterion A ¹⁾	pass
Rear	H	Criterion A	Criterion A ¹⁾	pass		
	V	Criterion A	Criterion A ¹⁾	pass		

NOTE: ¹⁾Before test, during the test, and after test, the EUT functions and works are normally.
The feedback information in EUT device logs is not interrupted.

For EN 301489-1/ EN301489-17:

Frequency	Field strength (V/m)	EUT orientation	Antenna polarization	Required criterion	Actual performance	Result
80MHz~6000MHz	3	Front	H	Criterion A	Criterion A ¹⁾	pass
			V	Criterion A	Criterion A ¹⁾	pass
		Left	H	Criterion A	Criterion A ¹⁾	pass
			V	Criterion A	Criterion A ¹⁾	pass
		Right	H	Criterion A	Criterion A ¹⁾	pass
			V	Criterion A	Criterion A ¹⁾	pass
Rear	H	Criterion A	Criterion A ¹⁾	pass		
	V	Criterion A	Criterion A ¹⁾	pass		

NOTE: ¹⁾Before test, during the test, and after test, the EUT functions and works are normally.
The feedback information in EUT device logs is not interrupted.

6.6 POWER FREQUENCY MAGNETIC FIELD IMMUNITY TEST

6.6.1 TEST SPECIFICATION

Test Requirement	EN 55035:2017/A11:2020
Test Method	IEC 61000-4-8:2009
Frequency	50Hz&60Hz
Field Strength	1 A/m
Observation Time	5 min
Inductance Coil	Rectangular type, 1mx1m
Direction	X-axis, Y-axis, Z-axis

6.6.2 TEST PROCEDURE

- The equipment is configured and connected to satisfy its functional requirements. It shall be placed on the GRP with the interposition of a 0.1m-thick insulating support.
- The equipment cabinets shall be connected to the safety earth directly on the GRP via the earth terminal of the EUT.
- The power supply, input and output circuits shall be connected to the sources of power supply, control and signal.
- The cables supplied or recommended by the equipment manufacturer shall be used. 1 meter of all cables used shall be exposed to the magnetic field.

6.6.3 TEST SETUP

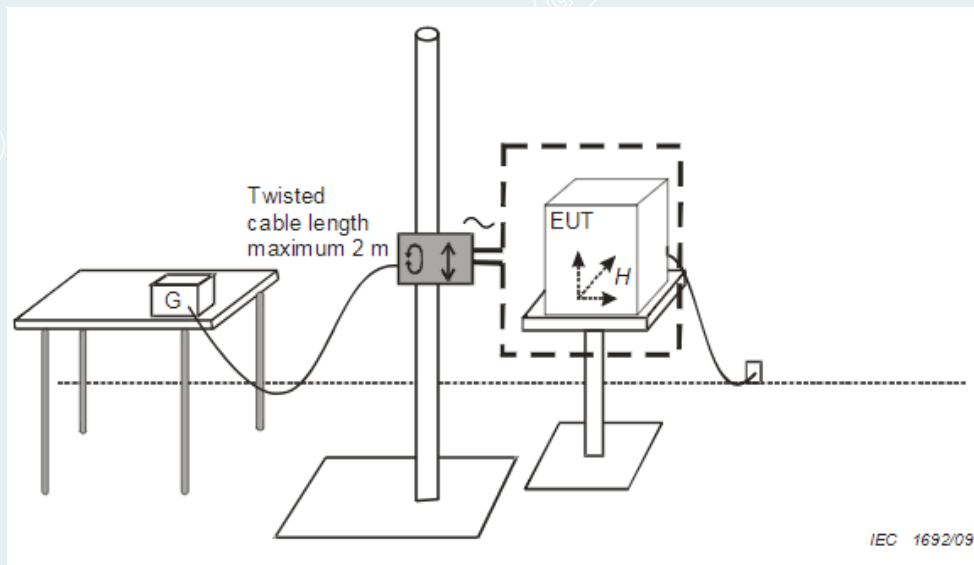

6.6.4 PHOTOGRAPH OF THE TEST ARRANGEMENT



----- The following blanks -----

6.6.5 TEST RESULTS

EUT Name	Cube T1 Pro	Model	CTP-R01
Environmental Conditions	24.5°C/45%RH/101kPa	Test Mode	Mode 1
Power supply	DC 3V	Tested By	Wang Xinyuan
Test Date	2022-04-28	Sample No.	E20220414157601-0001

Field Strength (A/m)	Frequency (Hz)	Observation Time (min)	Direction	Required Performance	Actual performance	Result
1	50	5	X	A	A ¹⁾	PASS
1	50	5	Y	A	A ¹⁾	PASS
1	50	5	Z	A	A ¹⁾	PASS
1	60	5	X	A	A ¹⁾	PASS
1	60	5	Y	A	A ¹⁾	PASS
1	60	5	Z	A	A ¹⁾	PASS

Note: ¹⁾Before test, during the test, and after test, the EUT functions and works are normally. The feedback information in EUT device logs is not interrupted.

----- The following blanks -----

APPENDIX A. PHOTOGRAPHS OF EUT

External Photos of EUT



EUT-1

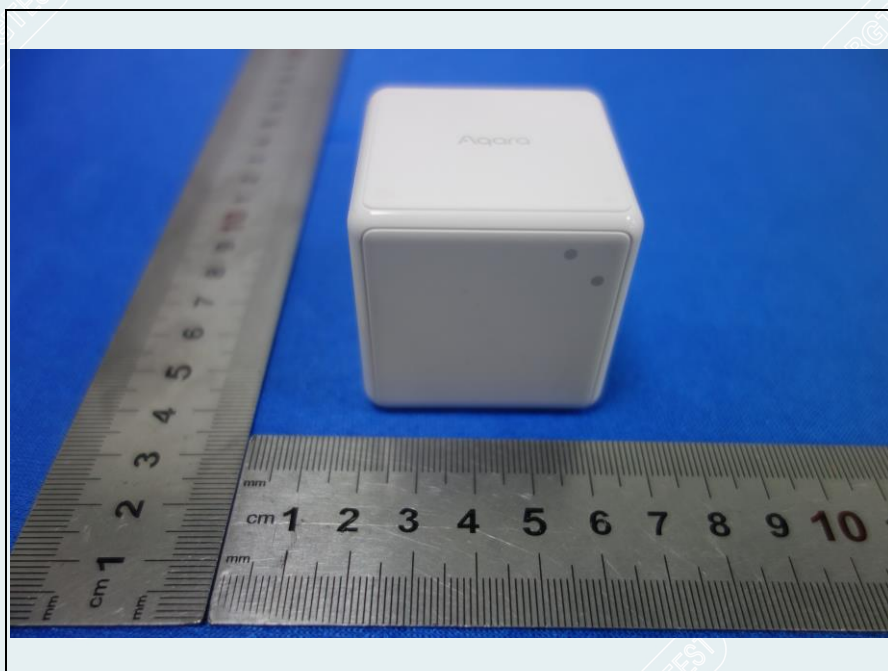

EUT-2

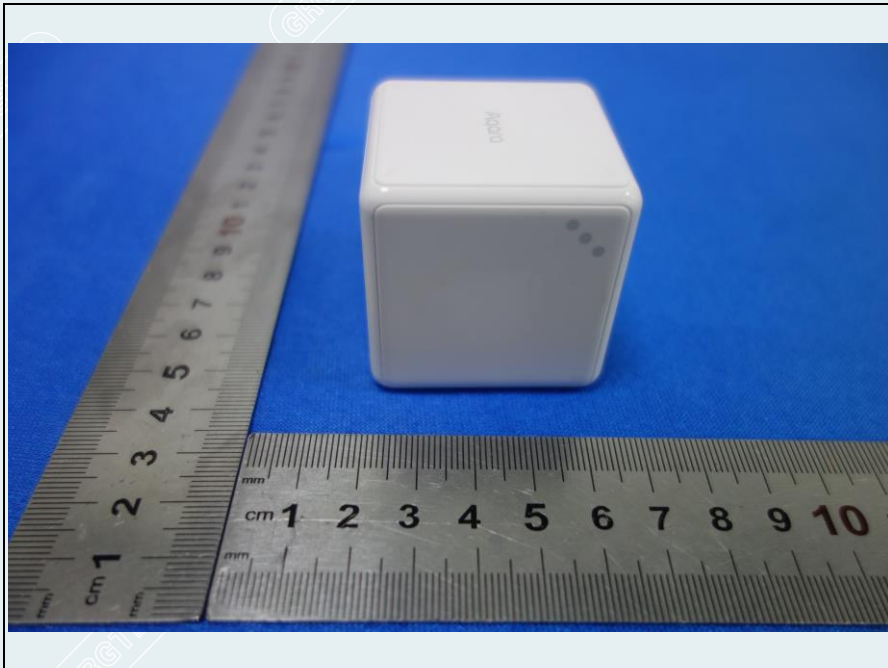

EUT-3

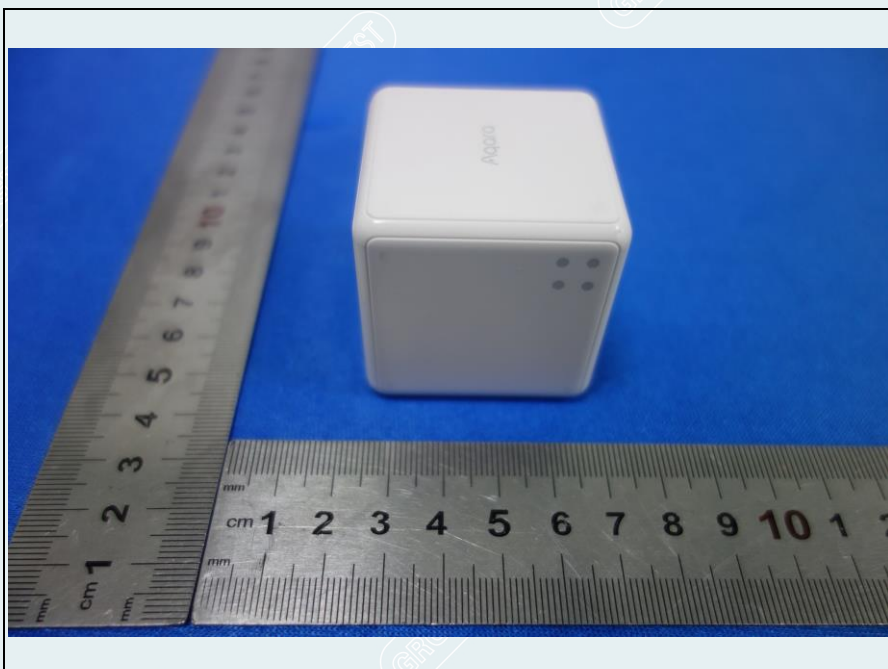

EUT-4



EUT-5



EUT-6

Internal Photos of EUT

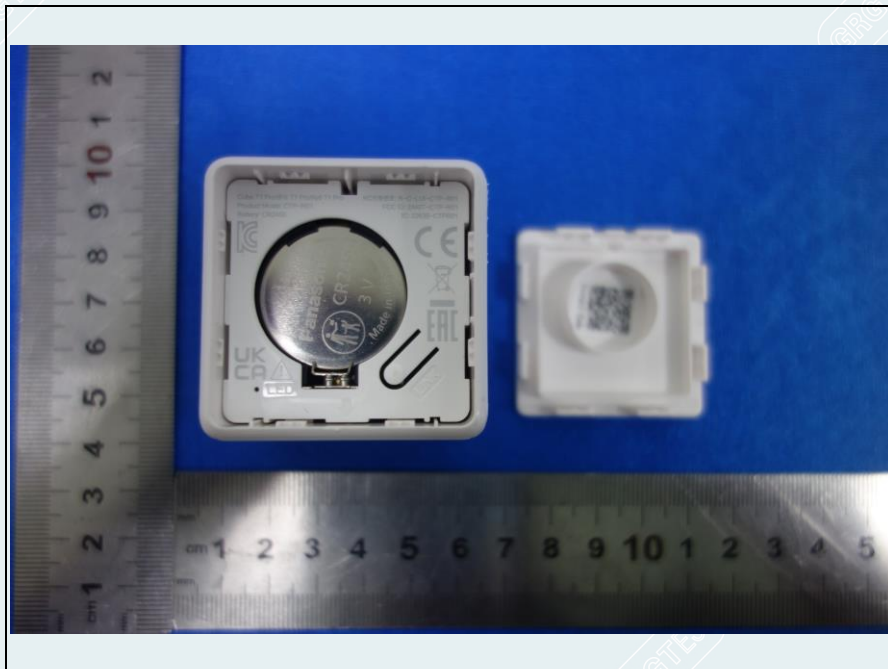

EUT-1

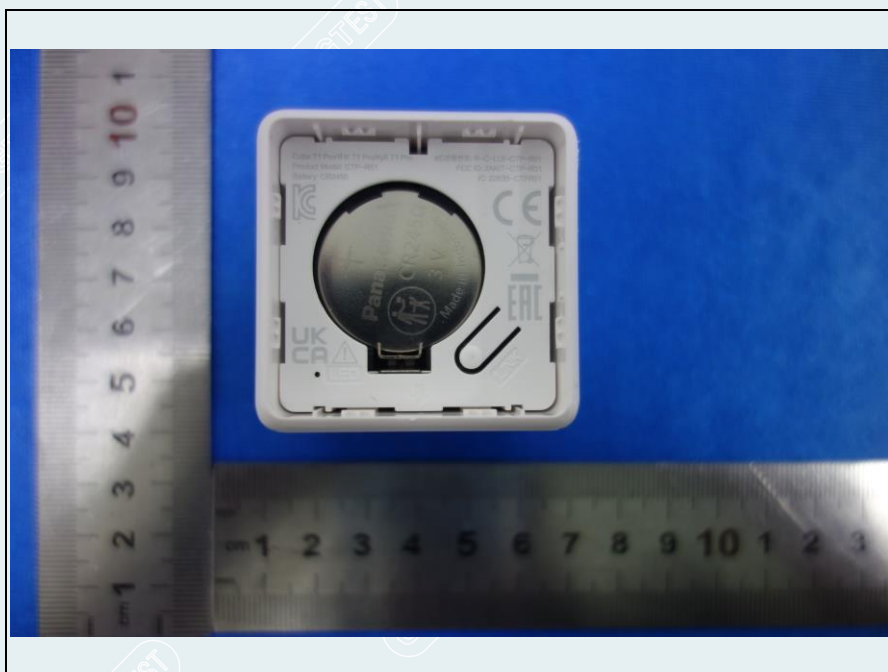

EUT-2

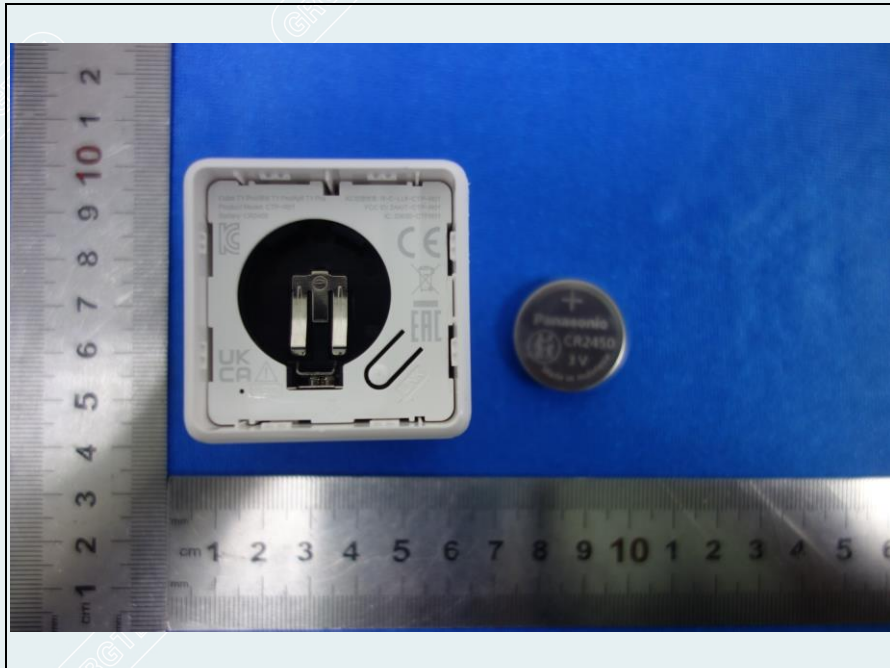

EUT-3



EUT-4

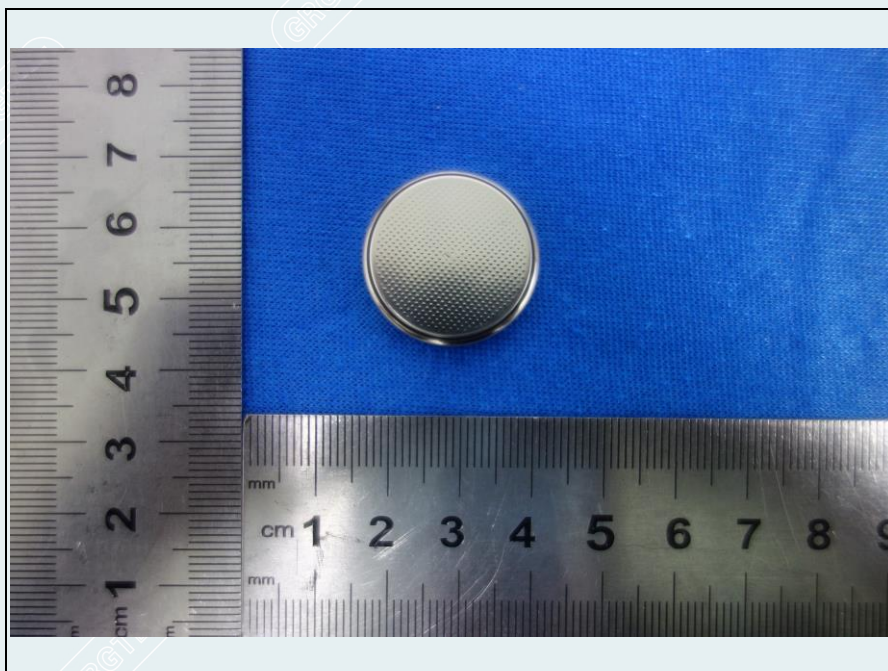

EUT-5

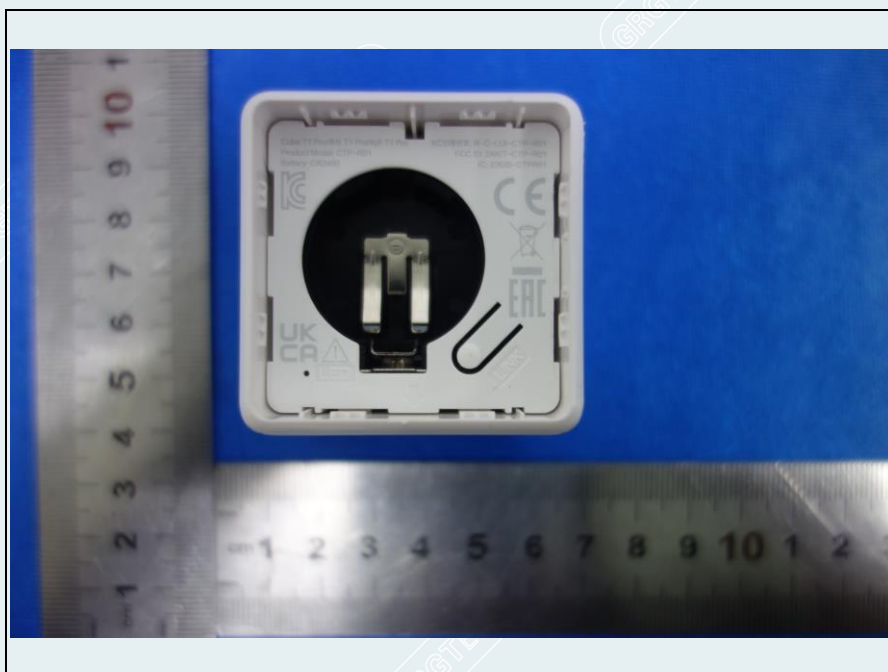

EUT-6

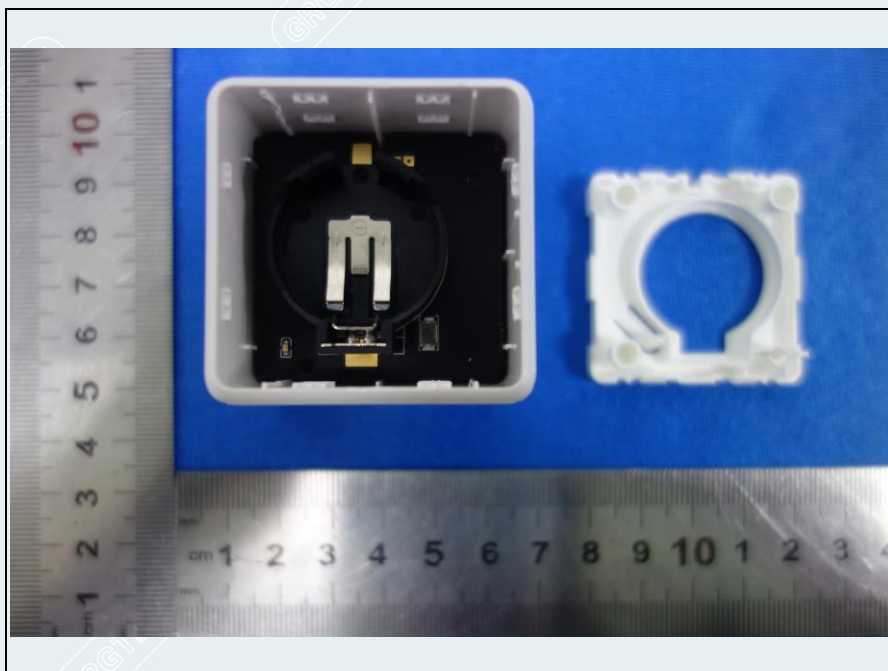

EUT-7

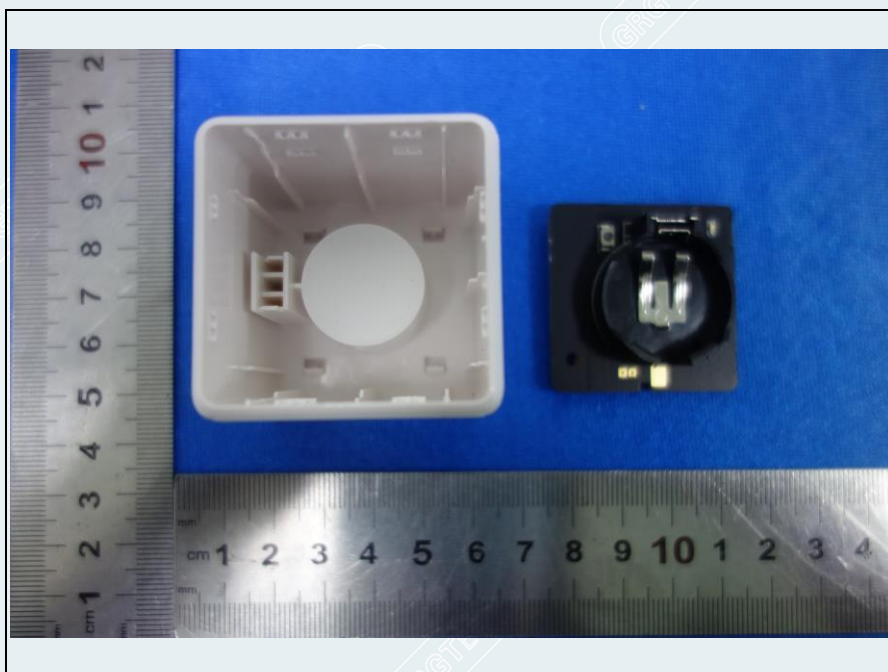

EUT-8

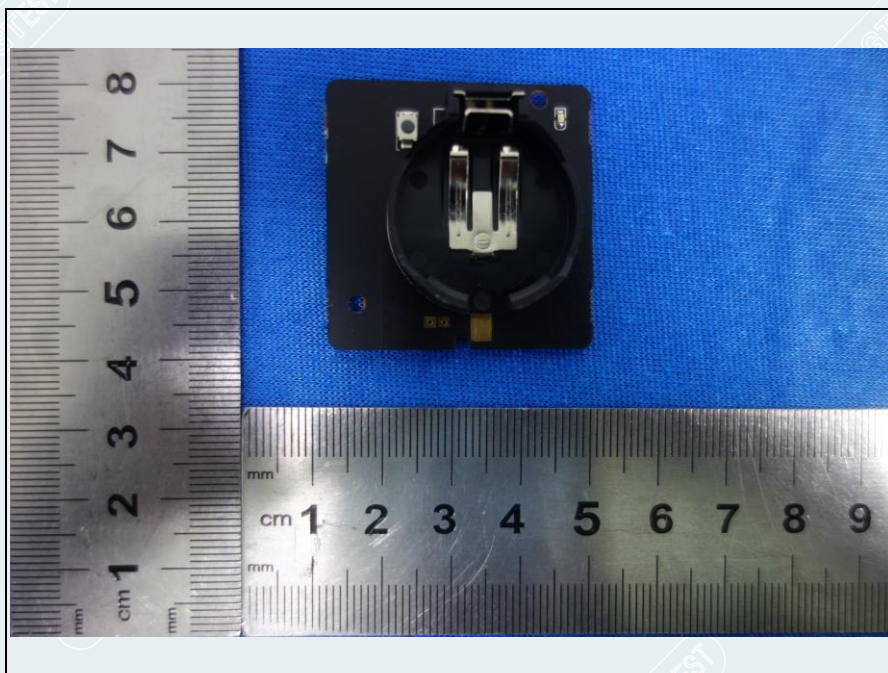

EUT-9

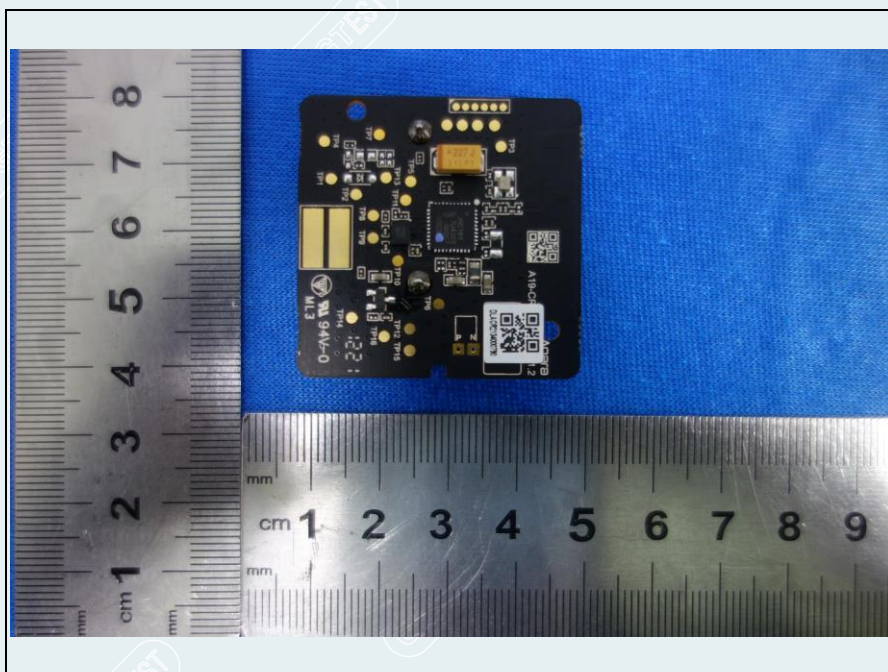

EUT-10

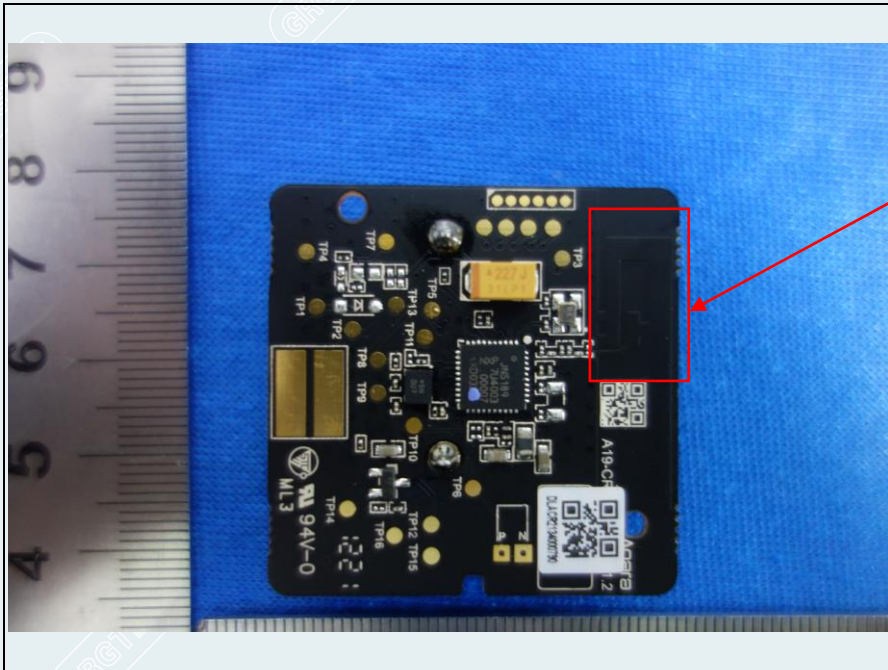

EUT-11

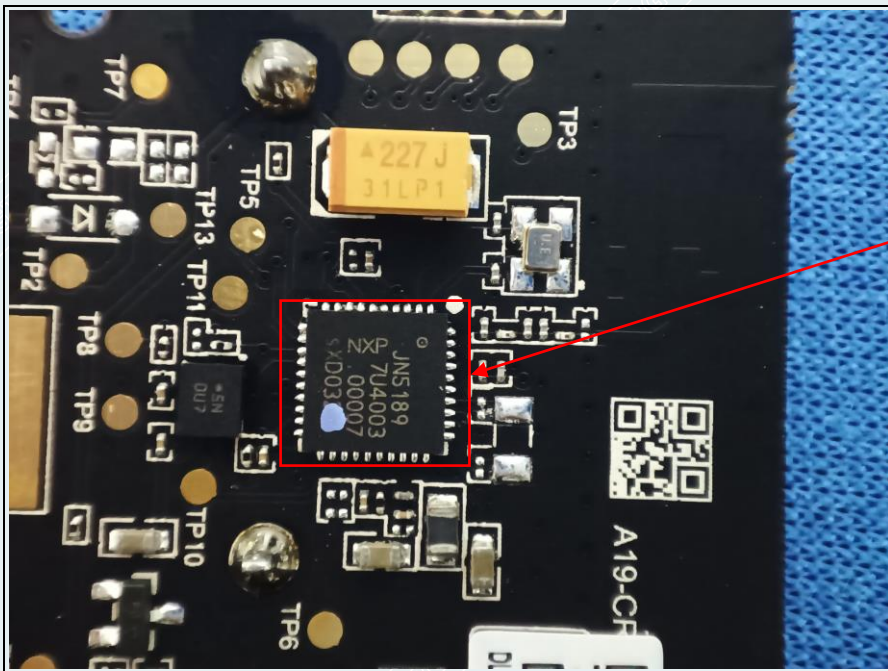

EUT-12

----- End of Report -----