

EMC Test Report

Applicant: Lumi United technology Co., Ltd.
Product: Smart Roller Shade controller
Model: SRSC-M01

In accordance with EN 55014-1, EN 55014-2, EN 61000-3-2,
EN IEC 61000-3-2:2019 and EN 61000-3-3





China

Add value.
Inspire trust.

Prepared for: Lumi United technology Co., Ltd.
8th Floor, JinQi Wisdom Valley, No.1 Tangling Road, Liuxian Ave, Taoyuan
Residential District, Nanshan District, Shenzhen, China.

COMMERCIAL-IN-CONFIDENCE

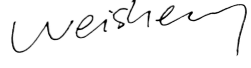
Report Number: 4840120503000A

RESPONSIBLE FOR	NAME	SIGNATURE	DATE
Approved By	Weisheng Jiang		2020. 11. 27
Prepared By	Zelin Gao		2020. 11. 27

Signatures in this approval box have checked this document in line with the requirements of TÜV SÜD Product Service control rules.

EXECUTIVE SUMMARY

A sample of this product was tested and found to be in compliance with EN 55014-1:2017, EN 55014-2:2015, EN 61000-3-2:2014, EN IEC 61000-3-2:2019, EN 61000-3-3:2013/A1:2019 and EN 61000-3-3:2013.

DISCLAIMER AND COPYRIGHT

This non-binding report has been prepared by TÜV SÜD Product Service with all reasonable skill and care. The reports apply only to the specific samples tested under stated test conditions. The document is confidential to the potential Client and TÜV SÜD Product Service. No part of this document may be reproduced without the prior written approval of TÜV SÜD Product Service.

TÜV SÜD Certification and Testing
(China) Co., Ltd.

No.10 Huaxia Road (M), Dongting,
Wuxi, 214100
P.R.China

Phone: +86 510 8820 3737
Fax: +86 510 8820 3636
www.tuv-sud.cn

ID Number: EMC_WUX_F_25.43E
Revision:5.1
Effective:2017-06-22

TÜV®



Contents

1	Report Summary	3
1.1	Report Modification Record.....	3
1.2	Introduction.....	3
1.3	Brief Summary of Results	4
1.4	Product Information	5
1.5	Deviations from the Standard.....	6
1.6	Test Location.....	6
2	Test Details	7
2.1	Conducted Disturbance at Mains Terminals	7
2.2	Disturbance power	14
2.3	Harmonic current emission	18
2.4	Flicker	23
2.5	Electrostatic discharge immunity test.....	26
2.6	Electrical fast transient /burst immunity test.....	29
2.7	Immunity to conducted disturbances, induced by radio-frequency fields	32
2.8	Surge immunity test.....	35
2.9	Voltage dips, short interruptions and voltage variations immunity tests	38
3	Test Equipment Information	41
3.1	General Test Equipment Used.....	41
4	Measurement Uncertainty	42
5	Photographs	43

1 Report Summary

1.1 Report Modification Record

Alterations and additions to this report will be issued to the holders of each copy in the form of a complete document.

Issue	Description of Change	Date of Issue
1	First Issue	27/11/2020

1.2 Introduction

The information contained in this report is intended to show verification of the EMC Qualification Approval Testing of the requirements of the standards for the tests listed in Section 1.3.

Applicant	Lumi United technology Co., Ltd.
address	8th Floor, JinQi Wisdom Valley, No.1 Tangling Road, Liuxian Ave, Taoyuan Residential District, Nanshan District, Shenzhen, China.
Manufacturer	Lumi United technology Co., Ltd.
address	8th Floor, JinQi Wisdom Valley, No.1 Tangling Road, Liuxian Ave, Taoyuan Residential District, Nanshan District, Shenzhen, China.
Factory	Ningbo Dooya Mechanic & Electronic Technology Co., Ltd
Model Number(s)	SRSC-M01
Rated input voltage/ frequency	220-230V~ 50Hz
Rated input power	121W
Sample(s) Tested	SRSC-M01
Sample Number(s)	522559
Number of Samples Tested	1
Test Specification	EN 55014-1:2017, EN 61000-3-2:2014, EN IEC 61000-3-2:2019, EN 61000-3-3:2013, EN 61000-3-3:2013/A1:2019 and EN 55014-2:2015
Date of Receipt of EUT	24/10/2020
Start of Test	25/10/2020
Finish of Test	28/10/2020
Name of Engineer(s)	Zelin Gao, Xin Feng

1.3 Brief Summary of Results

A brief summary of the tests carried out in accordance with EN 55014-1, EN 61000-3-2, EN 61000-3-3, EN IEC 61000-3-2:2019 and EN 55014-2 is shown below.

Section	Specification	Clause	Test Description	Result	Comments/Base Standard
Power on					
2.1	EN 55014-1:2017	4.3.3.6	Conducted Disturbance at Mains Terminals	Pass	
2.3	EN 55014-1:2017	4.3.4.4	Disturbance power	Pass	
2.3	EN 61000-3-2:2014	7	Harmonic current emission	Pass	
switch on/off					
2.4	EN 61000-3-3:2013	6	Flicker	Pass	
Power on					
2.5	EN 55014-2:2015	5.1	Electrostatic discharge immunity test	Pass	IEC 61000-4-2
2.6	EN 55014-2:2015	5.2	Electrical fast transient /burst immunity test	Pass	IEC 61000-4-4
2.7	EN 55014-2:2015	5.3	Immunity to conducted disturbances, induced by radio-frequency fields	Pass	IEC 61000-4-6
2.8	EN 55014-2:2015	5.6	Surge immunity test	Pass	IEC 61000-4-5
2.9	EN 55014-2:2015	5.7	Voltage dips, short interruptions and voltage variations immunity tests	Pass	IEC 61000-4-11



1.4 Product Information

1.4.1 Technical Description

The Equipment Under Test (EUT) was a Smart Roller Shade controller

1.4.2 EUT Port/Cable Identification

Port	Max Cable Length specified	Usage	Type	Screened
Power on				
AC Power port	1.0m	Power line	3 core	No

1.4.3 Test Configuration

Configuration	Description
1:AC Powered	230V AC 50Hz

1.4.4 Modes of Operation

Mode	Description
1: Power on	Normal working
2: switch on/off	The EUT was switch on/off

1.4.5 Monitoring of Performance

The EUT works normally, the motor speed changed less than 10%.

1.4.6 Performance Criteria

Performance criterion A: The apparatus shall continue to operate as intended during the test. No degradation of performance or loss of function is allowed below a performance level specified by the manufacturer, when the apparatus is used as intended. If the minimum performance level or the permissible performance loss is not specified by the manufacturer, then either of these may be derived from the product description and documentation, and from what the user may reasonable expect from the apparatus if used as intended.

Performance criterion B: The apparatus shall continue to operate as intended after the test. No degradation of performance or loss of function is allowed below a performance level specified by the manufacturer, when the apparatus is used as intended. During the test, degradation of performance is allowed, however no change of actual operating state or stored data is allowed to persist after test. If the minimum performance level or the permissible performance loss is not specified by the manufacturer, then either of these may be derived from the product description and documentation, and from what the user may reasonable expect from the apparatus if used as intended.

Performance criterion C: Temporary loss of function is allowed, provided the function is self-recoverable or can be restored by the operation of the controls, or by any operation specified in the instruction for use.



1.5 Deviations from the Standard

No deviations from the applicable test standard were made during testing.

1.6 Test Location

TÜV SÜD Product Service conducted the following tests at TÜV SÜD Certification and Testing (China) Co., Ltd.

Address:

No. 10 Huaxia Road (M)
 Dongting
 Wuxi
 Jiangsu Province
 214100
 China

Test Name	Name of Engineer(s)
Conducted Disturbance at Mains Terminals	Xin Feng
Disturbance power	Xin Feng
Harmonic Current Emissions	Xin Feng
Electrical fast transient /burst immunity test	Xin Feng
Immunity to conducted disturbances, induced by radio-frequency fields	Xin Feng
Surge immunity test	Xin Feng
Voltage dips, short interruptions and voltage variations immunity tests	Xin Feng
Electrostatic discharge immunity test	Xin Feng
Flicker	Xin Feng

2 Test Details

2.1 Conducted Disturbance at Mains Terminals

2.1.1 Specification Reference

EN 55014-1:2017 Clause 4.3.3.6

2.1.2 Equipment Under Test

SRSC-M01

2.1.3 Date of Test

28/10/2020

2.1.4 Test Method

The EUT was placed on a non-conductive table 0.4m above a reference ground plane. All power was connected to the EUT through an Artificial Mains Network (AMN). Conducted disturbance voltage measurements on mains lines were made at the output of the AMN. The AMN was placed 0.8m from the boundary of the EUT and bonded to the reference ground plane.

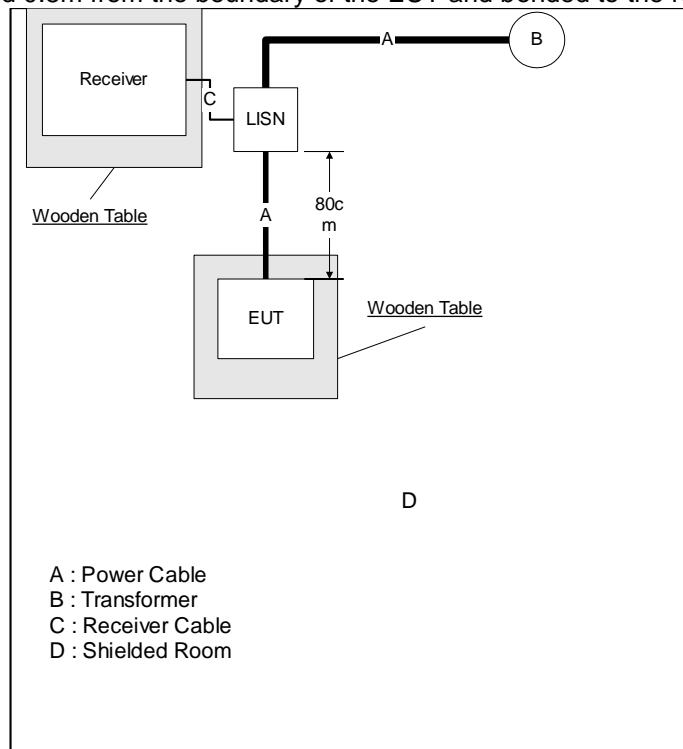



2.1.5 Environmental Conditions

Ambient Temperature 25.0 °C
 Relative Humidity 51.0 %
 Atmospheric Pressure 1012.0 mbar

2.1.6 Specification Limits

Household appliances and equipment causing similar disturbances and regulating controls incorporating semiconductor devices						
Frequency range MHz	Disturbance voltage at main terminals		Disturbance voltage at associated ports		Disturbance current at associated ports	
	Quasi-peak dBµV	Average dBµV	Quasi-peak dBµV	Average dBµV	Quasi-peak dBµA	Average dBµA
0.15 to 0.5	66 to 56	59 to 46	80	70	40 to 30	30 to 20
0.5 to 5	56	46	74	64	30	20
5 to 30	60	50	74	64		

2.1.7 Test Results

Results for Configuration and Mode: Configuration1 and mode1

Performance assessment of the EUT made during this test: Pass.



150KHz-30MHz Conducted Emission Test
SRSC-M01

EUT: Smart Roller Shade controller
 Manuf: Lumi United technology Co., Ltd.
 Op Cond: Power on ,AC 230V 50Hz
 Operator: Xin Feng
 Test Spec: 55014-1
 Comment: Phase L
 Sample No:522559
 Result File: CE-L1.dat : New Measurement

Scan Settings (1 Range)

Frequencies			Receiver Settings					
Start	Stop	Step	IF BW	Detector	M-Time	Atten	Preamp	OpRge
150kHz	30MHz	0.6%	10kHz	PK+AV	50msec	Auto	OFF	60dB

Transducer	No.	Start	Stop	Name
	1	9kHz	30MHz	NSLK8127

Final Measurement:

Detectors:	X QP / + AV
Meas Time:	1sec
Subranges:	16
Acc Margin:	6 dB

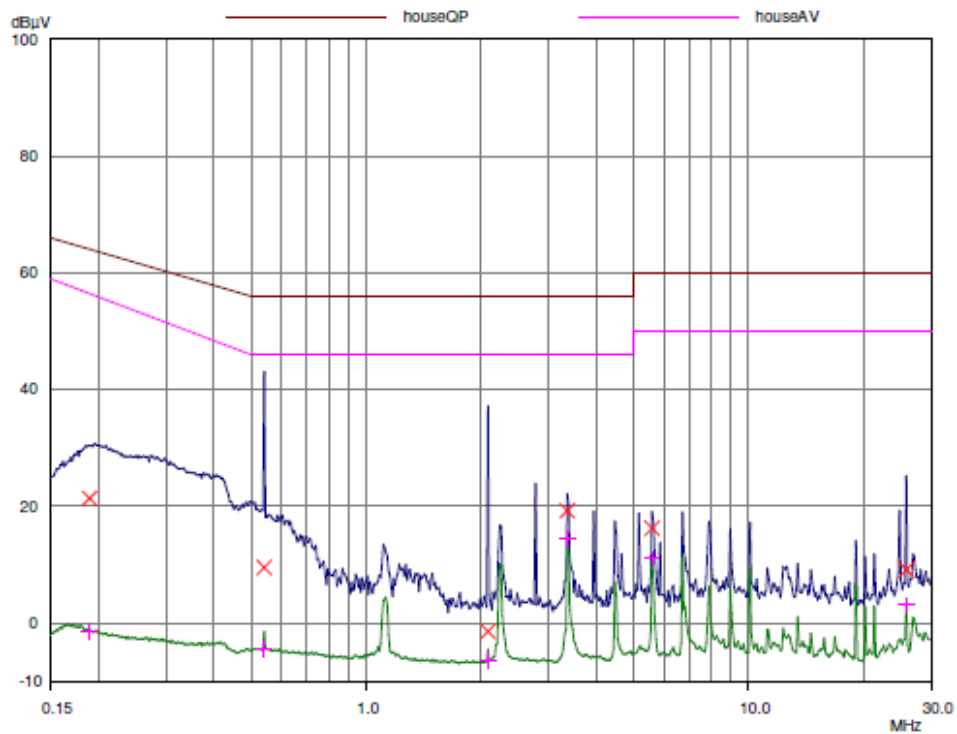



150KHz-30MHz Conducted Emission Test
SRSC-M01

EUT: Smart Roller Shade controller
 Manuf: Lumi United technology Co., Ltd.
 Op Cond: Power on ,AC 230V 50Hz
 Operator: Xin Feng
 Test Spec: 55014-1
 Comment: Phase L
 Sample No:522559
 Result File: CE-L1.dat : New Measurement

Scan Settings (1 Range)

Frequencies			Receiver Settings					
Start	Stop	Step	IF BW	Detector	M-Time	Atten	Preamp	OpRge
150kHz	30MHz	0.8%	10kHz	PK+AV	50msec	Auto	OFF	60dB

Transducer	No.	Start	Stop	Name
	1	9kHz	30MHz	NSLK8127

Final Measurement: Detectors: X QP / + AV
 Meas Time: 1sec
 Subranges: 16
 Acc Margin: 6 dB

Final Measurement Results

Frequency MHz	QP Level dBµV	QP Limit dBµV	QP Delta dB
0.18899	21.36	64.06	42.72
0.54104	9.52	56.00	46.48
2.08001	-1.45	56.00	57.45
3.35504	19.24	56.00	36.76
5.58692	16.25	60.00	43.75
25.79853	9.13	60.00	50.87

Frequency MHz	AV Level dBµV	AV Limit dBµV	AV Delta dB
0.18899	-1.37	56.51	57.88
0.54104	-4.48	46.00	50.48
2.08001	-6.36	46.00	52.36
3.35504	14.47	46.00	31.53
5.58692	11.02	50.00	38.98
25.79853	3.09	50.00	46.91



150KHz-30MHz Conducted Emission Test
SRSC-M01

EUT: Smart Roller Shade controller
 Manuf: Lumi United technology Co., Ltd.
 Op Cond: Power on ,AC 230V 50Hz
 Operator: Xin Feng
 Test Spec: 55014-1
 Comment: Phase N
 Sample No:522559
 Result File: CE-N1.dat : New Measurement

Scan Settings			(1 Range)		Receiver Settings				
Start	Stop	Step	IF BW	Detector	M-Time	Atten	Preamp	OpRge	
150kHz	30MHz	0.8%	10kHz	PK+AV	50msec	Auto	OFF	60dB	

Transducer	No.	Start	Stop	Name
	1	9kHz	30MHz	NSLK8127

Final Measurement:	Detectors:	X QP / + AV
	Meas Time:	1sec
	Subranges:	16
	Acc Margin:	6 dB

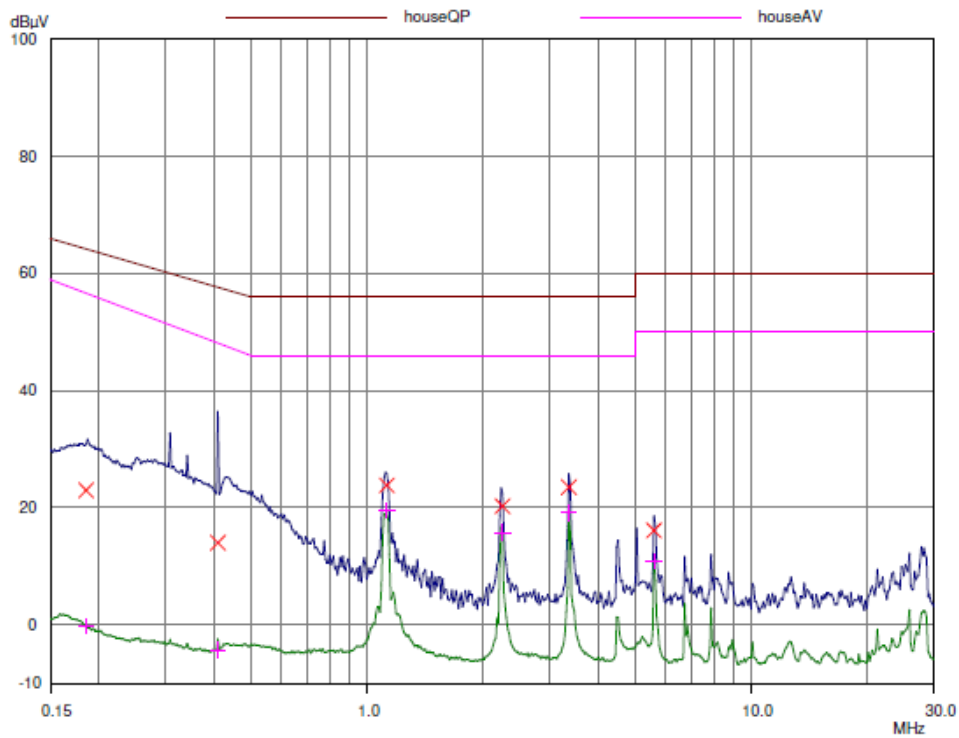



**150KHz-30MHz Conducted Emission Test
SRSC-M01**

EUT: Smart Roller Shade controller
 Manuf: Lumi United technology Co., Ltd.
 Op Cond: Power on ,AC 230V 50Hz
 Operator: Xin Feng
 Test Spec: 55014-1
 Comment: Phase N
 Sample No:522559
 Result File: CE-N1.dat : New Measurement

Scan Settings (1 Range)

Frequencies			Receiver Settings					
Start	Stop	Step	IF BW	Detector	M-Time	Atten	Preamp	OpRge
150kHz	30MHz	0.8%	10kHz	PK+AV	50msec	Auto	OFF	60dB

Transducer	No.	Start	Stop	Name
	1	9kHz	30MHz	NSLK8127

Final Measurement: Detectors: X QP / + AV
 Meas Time: 1sec
 Subranges: 16
 Acc Margin: 6 dB

Final Measurement Results

Frequency MHz	QP Level dBµV	QP Limit dBµV	QP Delta dB
0.186	23.00	64.21	41.21
0.40937	14.04	57.66	43.62
1.12617	23.84	56.00	32.16
2.25253	20.29	56.00	35.71
3.35504	23.52	56.00	32.48
5.58692	16.15	60.00	43.85

Frequency MHz	AV Level dBµV	AV Limit dBµV	AV Delta dB
0.186	-0.19	56.68	56.87
0.40937	-4.27	48.16	52.43
1.12617	19.60	46.00	26.40
2.25253	15.78	46.00	30.22
3.35504	19.15	46.00	26.85
5.58692	10.82	50.00	39.18



Test Setup

2.1.8 Test Location

This test was carried out in shielded room C.

2.2 Disturbance power

2.2.1 Specification Reference

EN 55014-1:2017, Clause 4.3.4.4

2.2.2 Equipment Under Test

SRSC-M01

2.2.3 Date of Test

29/10/2020

2.2.4 Test Method

The equipment under test was placed on a non-metallic table of 0.8m above a reference ground plane and at least 0.8m from other metallic objects and from any person. The lead to be measured shall be stretched in a straight horizontal line for a length sufficient to accommodate the absorbing clamp. At each test frequency, the absorbing clamp shall be moved along the lead until the maximum value is found.

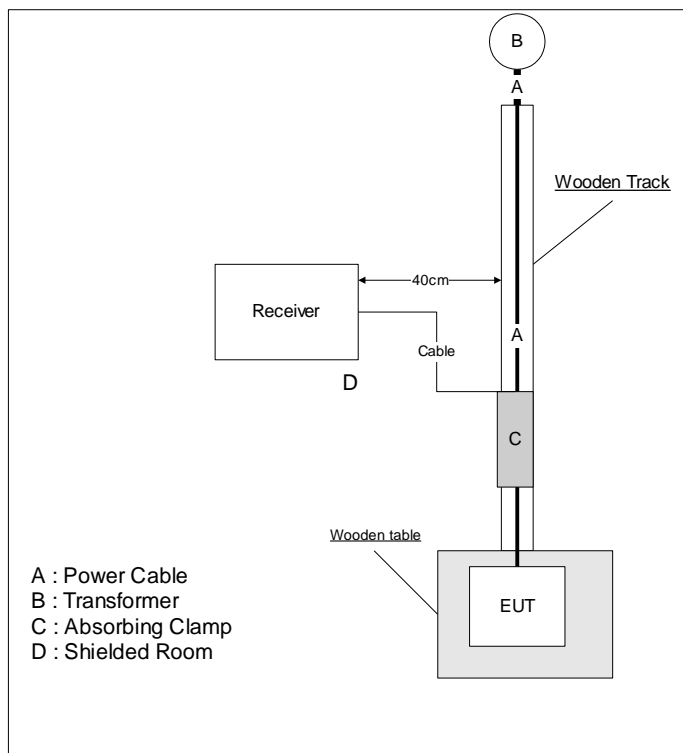



2.2.5 Environmental Conditions

Ambient Temperature 22.0 °C
 Relative Humidity 55.0 %
 Atmospheric Pressure 1012.0 mbar

2.2.6 Specification Limits

disturbance power limits for frequency range 30MHz to 300MHz		
Frequency range	Household and similar appliances dB(pW)	
MHz	Quasi-peak	Average
30 to 300	45 to 55	35 to 45

Margin when performing disturbance power measurement in the frequency range 30MHz to 300MHz		
Frequency range	Household and similar appliances dB(pW)	
MHz	Quasi-peak	Average
	Increasing linearly with the frequency from	
200 to 300	0 to 10 dB	0

2.2.7 Test Results

Results for Configuration and Mode: Configuration1 and mode1

Performance assessment of the EUT made during this test: Pass.

Data sheet:

Test Description: 30-300MHz Interference Power Test
 Operating Conditions: Configuration1 and mode1
 Operator Name: Xin Feng
 Test Standard: EN 55014-1
 Model: SRSC-M01

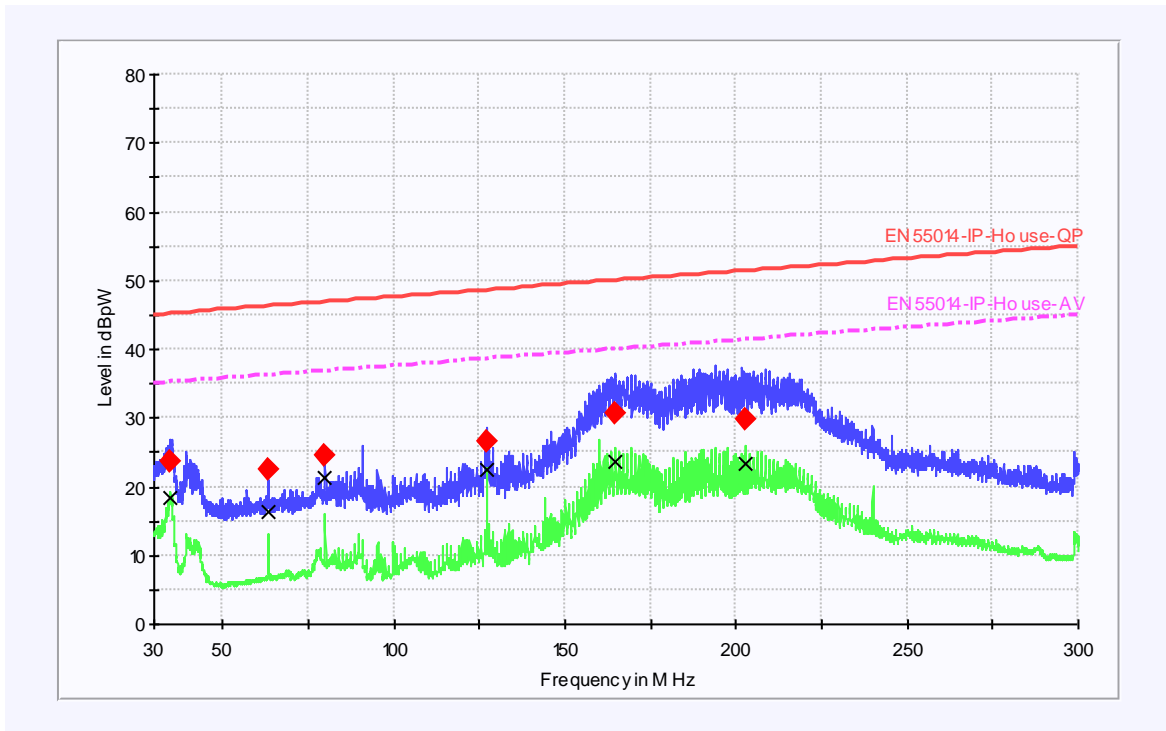

Result

Frequency (MHz)	QuasiPeak (dBpW)	Average (dBpW)	Margin - AVG (dB)	Margin - QPK (dB)
127.150000	26.6	22.5	16.8	21.6
80.050000	24.6	21.5	19.9	23.6
63.500000	22.6	16.4	15.4	22.2
34.700000	23.6	18.4	16.1	22.0
164.750000	30.7	23.6	16.4	19.3
203.000000	29.7	23.5	17.9	21.7



Test Setup

2.2.8 Test Location

This test was carried out in shielded room B.

2.3 Harmonic current emission

2.3.1 Specification Reference

EN 61000-3-2:2014, Clause 7

2.3.2 Equipment Under Test

SRSC-M01

2.3.3 Date of Test

26/10/2020

2.3.4 Test Method

Harmonic current test should be conducted with the user's operation control or automatic programs set to the mode expected to produce the maximum total harmonic current under normal operating conditions.

Specific test conditions for the measurement of harmonic currents associated with some types of equipment are given in Annex C.

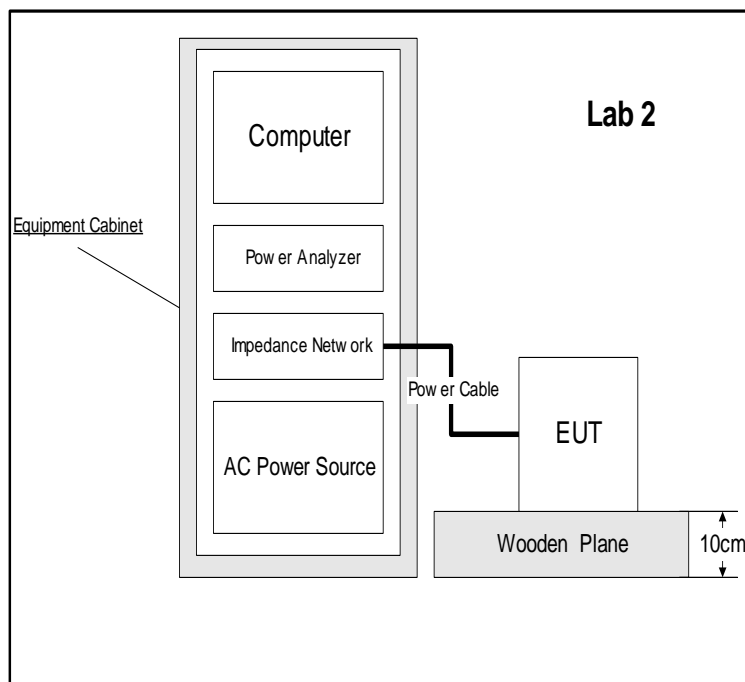

2.3.5 Environmental Conditions

Ambient Temperature	25.0 °C
Relative Humidity	51.0 %
Atmospheric Pressure	1012.0 mbar

2.3.6 Specification Limits

Harmonic order n	Maximum permissible harmonic current A
Odd harmonics	
3	2,30
5	1,14
7	0,77
9	0,40
11	0,33
13	0,21
$15 \leq n \leq 39$	$0,15 \frac{15}{n}$
Even harmonics	
2	1,08
4	0,43
6	0,30
$8 \leq n \leq 40$	$0,23 \frac{8}{n}$

2.3.7 Test Results

Results for Configuration and Mode: Configuration1 and mode1

Performance assessment of the EUT made during this test: *Pass*.

Detailed results are shown below:

Classification of EUT: Class A



Harmonics – Class-A per Ed. 4.0 (2014)(Run time) incl. inter-harmonics

EUT: Smart Roller Shade controller
Test category: Class-A per Ed. 4.0 (2014) (European limits) Tested by: Xin Feng
Test date: 10/26/2020 Start time: 3:41:25 PM End time: 3:44:08 PM
Test duration (min): 2.5 Data file name: CTSMXL_H-000055.cts_data
Comment: Power on, AC 230V 50Hz
Sample No:522559
Customer: Lumi United Technology Co.,Ltd

Test Result: Pass Source qualification: Normal

Current & voltage waveforms

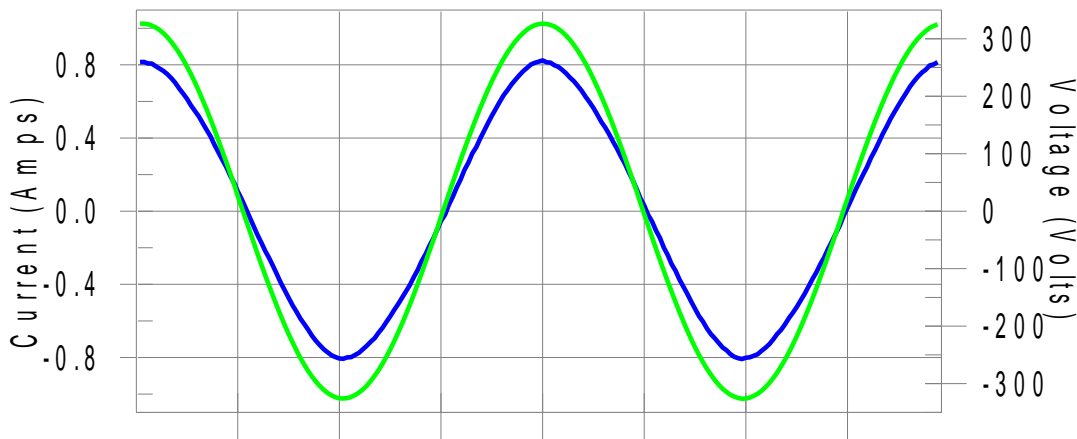

Harmonics and Class A limit line European Limits

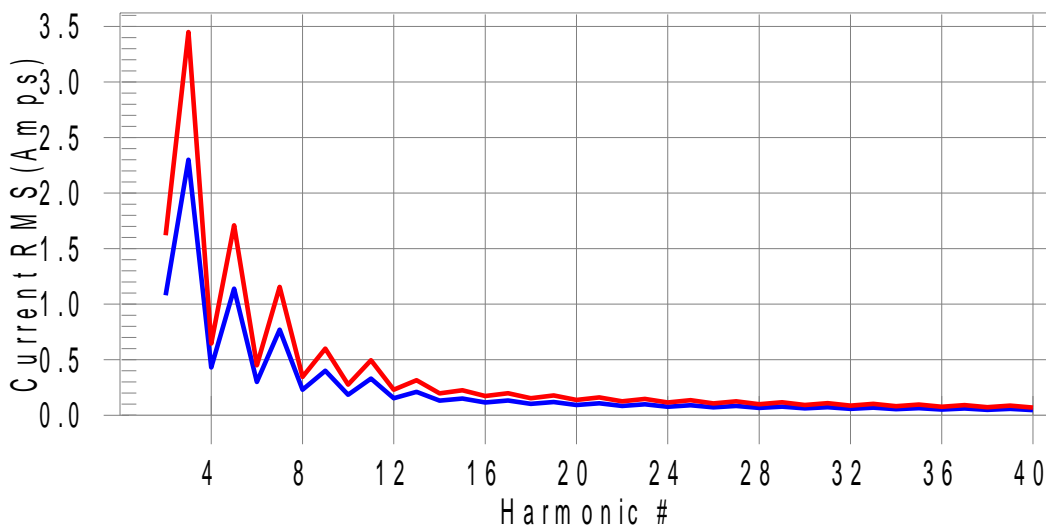

Test result: Pass Worst harmonics H3-0.4% of 150% limit, H3-0.5% of 100% limit.



Current Test Result Summary (Run time)

EUT: Smart Roller Shade controller
 Test category: Class-A per Ed. 4.0 (2014) (European limits)
 Test date: 10/26/2020 Start time: 3:41:25 PM End time: 3:44:08 PM
 Test duration (min): 2.5 Data file name: CTSMXL_H-000055.cts_data
 Comment: Power on, AC 230V 50Hz
 Sample No:522559
 Customer: Lumi United Technology Co.,Ltd

Tested by: Xin Feng
 Test Margin: 100

Test Result: Pass Source qualification: Normal
 THC(A): 0.012 I-THD(%): 2.3 POHC(A): 0.001 POHC Limit(A): 0.251

Highest parameter values during test:

V_RMS (Volts): 230.627	Frequency(Hz): 50.00
I_Peak (Amps): 0.826	I_RMS (Amps): 0.558
I_Fund (Amps): 0.558	Crest Factor: 1.484
Power (Watts): 128.5	Power Factor: 0.999

Harm#	Harms(avg)	100%Limit	%of Limit	Harms(max)	150%Limit	%of Limit	Status
2	0.001	1.080	N/A	0.001	1.620	N/A	Pass
3	0.012	2.300	0.5	0.015	3.450	0.4	Pass
4	0.001	0.430	N/A	0.001	0.645	N/A	Pass
5	0.003	1.140	N/A	0.003	1.710	N/A	Pass
6	0.000	0.300	N/A	0.000	0.450	N/A	Pass
7	0.001	0.770	N/A	0.001	1.155	N/A	Pass
8	0.000	0.230	N/A	0.000	0.345	N/A	Pass
9	0.001	0.400	N/A	0.001	0.600	N/A	Pass
10	0.001	0.184	N/A	0.001	0.276	N/A	Pass
11	0.001	0.330	N/A	0.001	0.495	N/A	Pass
12	0.001	0.153	N/A	0.001	0.230	N/A	Pass
13	0.001	0.210	N/A	0.001	0.315	N/A	Pass
14	0.000	0.131	N/A	0.000	0.197	N/A	Pass
15	0.000	0.150	N/A	0.000	0.225	N/A	Pass
16	0.000	0.115	N/A	0.000	0.173	N/A	Pass
17	0.000	0.132	N/A	0.000	0.198	N/A	Pass
18	0.000	0.102	N/A	0.000	0.153	N/A	Pass
19	0.000	0.118	N/A	0.000	0.178	N/A	Pass
20	0.000	0.092	N/A	0.000	0.138	N/A	Pass
21	0.000	0.107	N/A	0.000	0.161	N/A	Pass
22	0.000	0.084	N/A	0.000	0.125	N/A	Pass
23	0.000	0.098	N/A	0.000	0.147	N/A	Pass
24	0.000	0.077	N/A	0.000	0.115	N/A	Pass
25	0.000	0.090	N/A	0.000	0.135	N/A	Pass
26	0.000	0.071	N/A	0.000	0.107	N/A	Pass
27	0.000	0.083	N/A	0.000	0.125	N/A	Pass
28	0.000	0.066	N/A	0.000	0.099	N/A	Pass
29	0.000	0.078	N/A	0.000	0.116	N/A	Pass
30	0.000	0.061	N/A	0.000	0.092	N/A	Pass
31	0.000	0.073	N/A	0.000	0.109	N/A	Pass
32	0.000	0.058	N/A	0.000	0.086	N/A	Pass
33	0.000	0.068	N/A	0.000	0.102	N/A	Pass
34	0.000	0.054	N/A	0.000	0.081	N/A	Pass
35	0.000	0.064	N/A	0.000	0.096	N/A	Pass
36	0.000	0.051	N/A	0.000	0.077	N/A	Pass
37	0.000	0.061	N/A	0.000	0.091	N/A	Pass
38	0.000	0.048	N/A	0.000	0.073	N/A	Pass
39	0.000	0.058	N/A	0.000	0.087	N/A	Pass
40	0.000	0.046	N/A	0.000	0.069	N/A	Pass



Test Setup

2.3.8 Test Location

This test was carried out in Harmonic Flicker Test area.

2.4 Flicker

2.4.1 Specification Reference

EN 61000-3-3:2013, Clause 6

2.4.2 Equipment Under Test

SRSC-M01

2.4.3 Date of Test

26/10/2020

2.4.4 Test Method

switch on/off

For equipment not mentioned in annex A, controls or automatic programs should be set to produce the most unfavorable sequence of voltage change, using only those combinations of controls and programmes which are mentioned by the manufacturer in the instruction manual, or are otherwise likely to be used

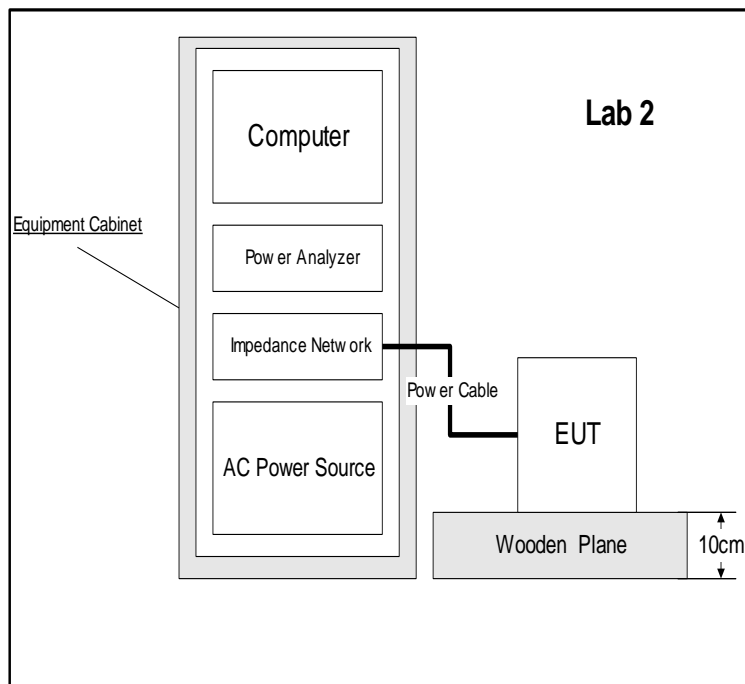



2.4.5 Environmental Conditions

Ambient Temperature 25.0 °C
 Relative Humidity 51.0 %
 Atmospheric Pressure 1012.0 mbar

2.4.6 Specification Limits

The value of Pst shall not be greater than 1.0
 The value of Plt shall not be greater than 0.65
 Tmax, the accumulated time value of d(t) with a deviation exceeding 3.3% during a single voltage change at the EUT terminals, shall not exceed 500ms
 The maximum relative steady-state voltage change, dc, shall not exceed 3.3%
 The maximum relative voltage change dmax, shall not exceed 4% without additional conditions
 6% for equipment which is:
 Switched manually, or
 Switched automatically more frequently than twice per day, and also has either a delayed start, or manual restart, after a power supply interruption
 7% for equipment which is:
 Attended whilst in use, or
 Switched on automatically, or is intended to be switched on manually, no more than twice per day, and also has either a delayed restart or manual restart, after a power supply interruption

2.4.7 Test Results

Results for Configuration and Mode: Configuration1 and mode2

Performance assessment of the EUT made during this test: *Pass*.

Detailed results are shown below:

Parameter values recorded during the test:

Vrms at the end of test (Volt):230.62

T-max (mS):	0.0	Test limit (mS):	500.0	Pass
Highest dc (%):	0.26	Test limit (%):	3.30	Pass
Highest dmax (%):	0.28	Test limit (%):	4.00	Pass
Highest dt (%):	0.24	Test limit (%):	N/A	N/A



Test Setup

2.4.8 Test Location

This test was carried out in Harmonic Flicker Test area.

2.5 Electrostatic discharge immunity test

2.5.1 Specification Reference

EN 55014-2:2015, Clause 5.1

2.5.2 Equipment Under Test

SRSC-M01

2.5.3 Date of Test

27/10/2020

2.5.4 Test Method

The equipment under test including associated cabling was configured on but insulated from, using a 0.5mm isolator, a horizontal coupling plane fitted to the top of a 0.8m non-conductive table for table-top equipment; and on a 0.1m insulated support for floor standing equipment; above a ground reference plane all within a test laboratory.

Using the air discharge method for non-metallic parts, contact discharge method for metallic parts with both vertical and horizontal couple plane discharge methods for the sides of the equipment under test, the required electrostatic discharge voltage levels in both voltage polarities were applied at the detailed pulse repartition rate.

During this testing any anomalies in the equipment under tests performance was recorded.

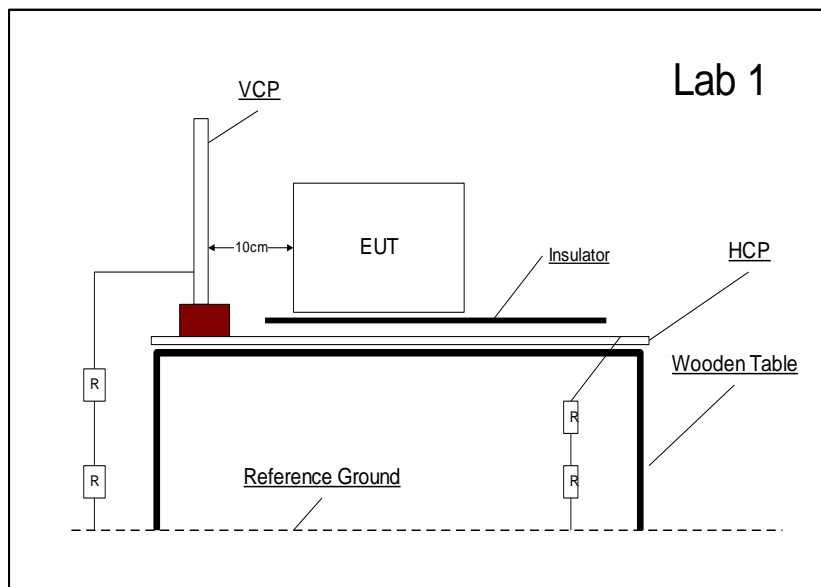



2.5.5 Environmental Conditions

Ambient Temperature 21.0 °C
 Relative Humidity 52.0 %
 Atmospheric Pressure 1009.0 mbar

2.5.6 Specification Limits

Required Test Levels				Performance Criteria
Discharge type	Discharge Level (kV)		Number of discharges per location (each polarity)	
	Positive	Negative		
Air – Direct	2, 4 and 8	2, 4 and 8	<10>	B
Contact – Direct	4	4	<10>	B
Contact – Indirect	4	4	<10>	B

2.5.7 Test Results

Results for Configuration and Mode: Configuration1 and mode1

Performance assessment of the EUT made during this test: Pass.

Detailed results are shown below.

ID	Test Point	Discharge	Results									
			2kV		4kV		6kV		8kV		15kV	
			+	-	+	-	+	-	+	-	+	-
	VCP/HCP/Enclosure	Contact	✓	✓	✓	✓						
	button	Air	✓	✓	✓	✓			✓	✓		

Key to Results	
✓	The EUTs performance was not impacted when the ESD pulse was applied.
✓*	No discharge occurred at this point when the ESD pulse was applied
Ox	
Fx	
N/A	Not Appliance



Test Setup

2.5.8 Test Location

This test was carried out in shielded room A.

2.6 Electrical fast transient /burst immunity test

2.6.1 Specification Reference

EN 55014-2:2015, Clause 5.2

2.6.2 Equipment Under Test

SRSC-M01

2.6.3 Date of Test

26/10/2020

2.6.4 Test Method

The equipment under test including associated cabling was configured on but insulated from, using a 0.1 m isolator, a horizontal coupling plane fitted to the top of a 0.8 m non-conductive table for table-top equipment; and on a 0.1 m insulated support for floor standing equipment; above a ground reference plane all within a test laboratory.

Using a CDN for power ports, capacitive coupling clamp for signal and control ports and a 33nF coupling capacitor for earth ports, the required fast transient burst voltage levels in both voltage polarities were applied at the detailed pulse repartition rate and duration of test.

During this testing any anomalies in the equipment under tests performance was recorded.

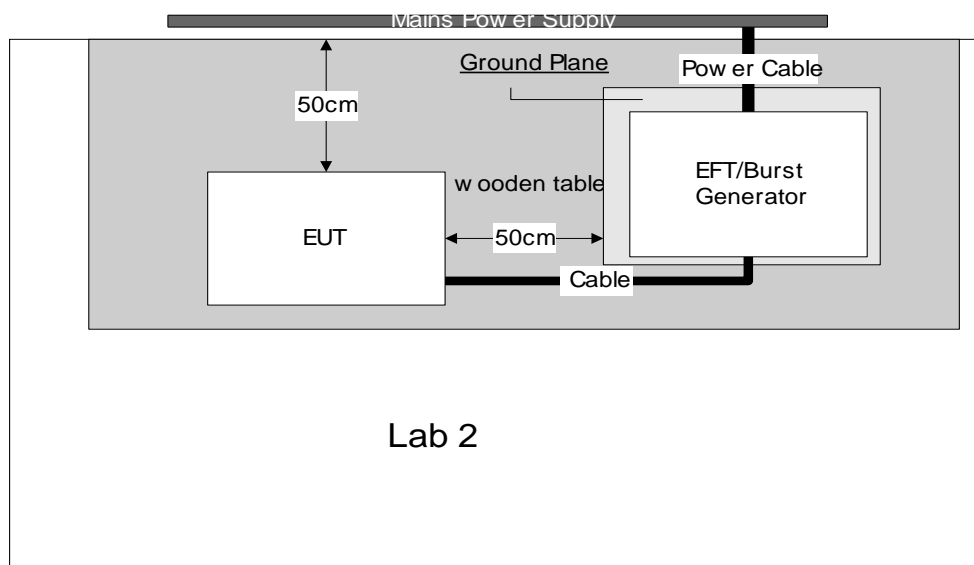



2.6.5 Environmental Conditions

Ambient Temperature 22.0 °C
 Relative Humidity 55.0 %
 Atmospheric Pressure 1012.0 mbar

2.6.6 Specification Limits

Required Test Levels Input and output a.c. power ports					Performance Criteria
Line Under Test	Level (kV)	Repetition Rate (kHz)	Test Duration	Coupling Method	
AC power port	± 1	5 kHz	2 min per polarity	CDN	B
For extra low voltage a.c. ports and output a.c. ports, this testing is only applicable to ports interfacing with cables whose total length may exceed 3m according to the manufacturer's functional specification.					

2.6.7 Test Results

Results for Configuration and Mode: Configuration1 and mode1

Performance assessment of the EUT made during this test: Pass.

Detailed results are shown below.

Tabulated Results for Fast Transient Burst Immunity					
Line under test	Test Level (kV)	Repetition Rate	Test Duration	Coupling Method	Result
Power line	±1.0 kV	5 kHz	2 min	CDN	Pass PC A

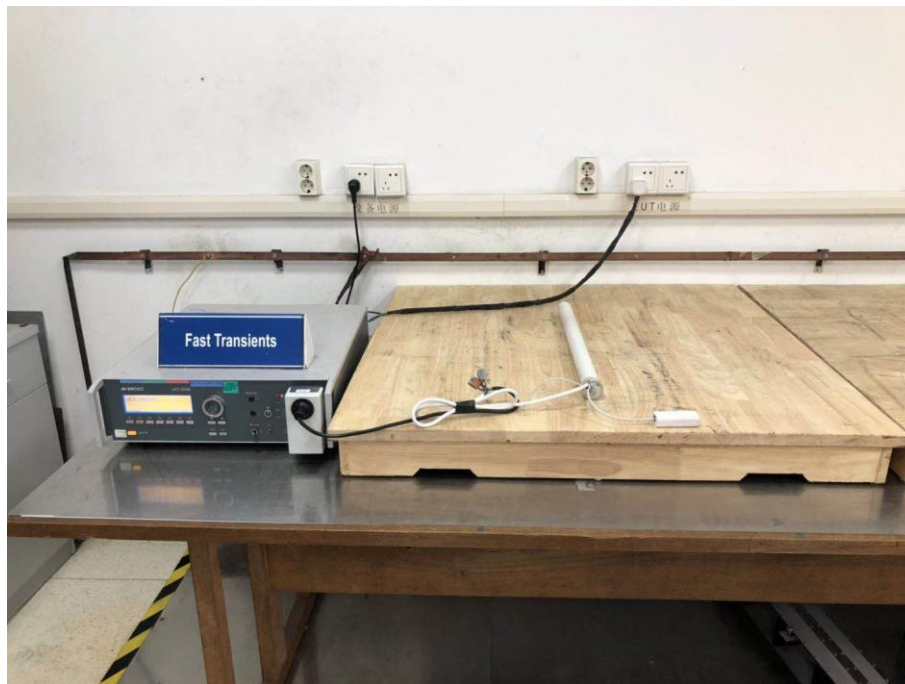

Test Setup

2.6.8 Test Location

This test was carried out in Immunity test location.

2.7 Immunity to conducted disturbances, induced by radio-frequency fields

2.7.1 Specification Reference

EN 55014-2:2015, Clause 5.3

2.7.2 Equipment Under Test

SRSC-M01

2.7.3 Date of Test

26/10/2020

2.7.4 Test Method

The equipment under test was configured, on but insulated from, using a 0.1 m isolator, on a 0.1 m insulated support for floor standing equipment; above a ground reference plane all within a test laboratory.

All associated cabling was configured, on but insulated from, using a 50 mm isolator, the same horizontal coupling plane as the equipment under test.

Using CDNs, EM Clamps or current clamps as appropriate, the power ports and applicable signal and control ports were subjected to the required, pre calibrated RF injected signal strength, modulated as described, swept over the frequency range of test.

During this testing any anomalies in the equipment under tests performance was recorded.

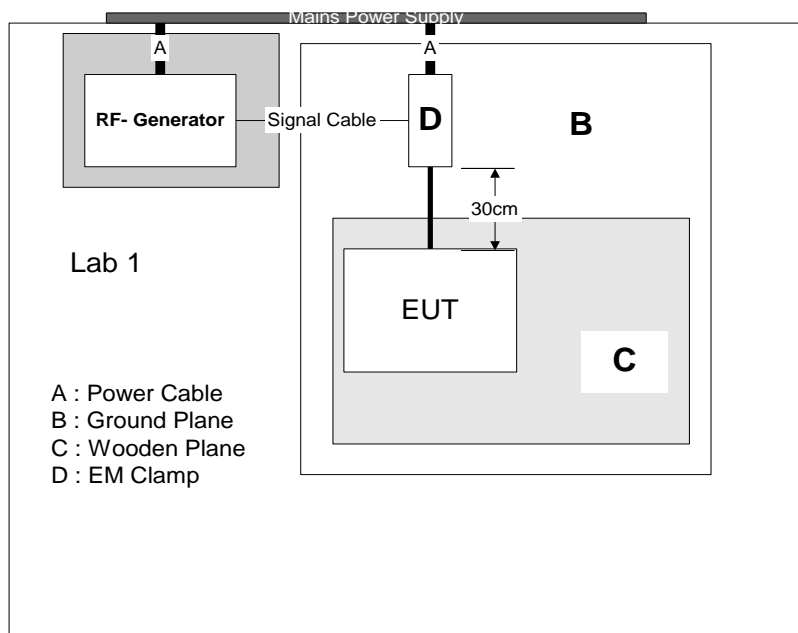



2.7.5 Environmental Conditions

Ambient Temperature 22.0 °C
 Relative Humidity 55.0 %
 Atmospheric Pressure 1012.0 mbar

2.7.6 Specification Limits

Required Test Levels Input and output a.c. power ports						Performance Criteria
Line Under Test	Frequency Range (MHz)	Level (V/m)	Modulation	Step Size (%)	Dwell (s)	
AC power port	0.15 to 230	3	AM (80 %,1 kHz, sine wave)	1	3	A
For extra low voltage a.c. ports and output a.c. ports, this testing is only applicable to ports interfacing with cables whose total length may exceed 3m according to the manufacturer's functional specification.						

2.7.7 Test Results

Results for Configuration and Mode: Configuration1 and mode1

Performance assessment of the EUT made during this test: Pass.

Detailed results are shown below.

Tabulated Results for Injected current						
Line under test	Test Level	Step	Dwell Time	Coupling Method	Modulation	Result
Power line	3V	1%	3S	CDN	1KHZ 80%	Pass PC A



Test Setup

2.7.8 Test Location

This test was carried out in Immunity test location.

2.8 Surge immunity test

2.8.1 Specification Reference

EN 55014-2:2015, Clause 5.6

2.8.2 Equipment Under Test

SRSC-M01

2.8.3 Date of Test

26/10/2020

2.8.4 Test Method

The equipment under test including associated cabling was configured, on a 0.1 m insulated support for floor standing equipment above a ground reference plane all within a test laboratory.

Using CDNs for power ports and appropriate coupling methods for applicable signal and control ports, the required number of surges was applied for each surge voltage level using both positive and negative surge voltage polarities. Surges were applied at the power line frequency phase angles and repartition rates detailed.

During this testing any anomalies in the equipment under tests performance was recorded.

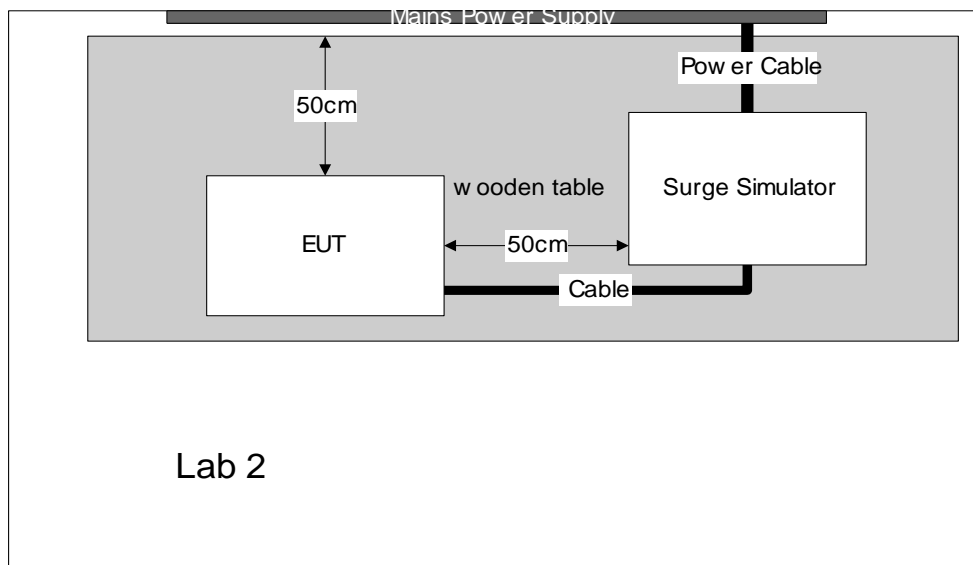



2.8.5 Environmental Conditions

Ambient Temperature 22.0 °C
 Relative Humidity 55.0 %
 Atmospheric Pressure 1012.0 mbar

2.8.6 Specification Limits

Characteristics	Test Levels	Performance Criteria
Wave- shape data Test levels line to line with 2Ω impedance line to earth with 12Ω impedance	1.2/50 μs ± 1.0 kV ±2.0 kV	B
Note In addition to the specified test level, all lower levels as detailed in IEC 61000-4-5 should also be satisfied.		

2.8.7 Test Results

Results for Configuration and Mode: Configuration1 and mode1

Performance assessment of the EUT made during this test: Pass.

Detailed results are shown below.

Tabulated Results for Surge Immunity (Power Ports)							
Line Name	Coupling	Level	Polarity	Phase Angle	No of Pulses	Repetition Rate	Result
Power line	Live to Neutral	+1.0kV	POSITIVE	90 deg	5	60 sec	Pass PC A
Power line	Live to Neutral	-1.0kV	NEGATIVE	270 deg	5	60 sec	Pass PC A



Test Setup

2.8.8 Test Location

This test was carried out in Immunity test location.

2.9 Voltage dips, short interruptions and voltage variations immunity tests

2.9.1 Specification Reference

EN 55014-2:2015, Clause 5.7

2.9.2 Equipment Under Test

SRSC-M01

2.9.3 Date of Test

26/10/2020

2.9.4 Test Method

The equipment under test including associated cabling was configured, on a 0.8 m non-conductive table for table-top equipment and on a 0.1 m insulated support for floor standing equipment above a ground reference plane all within a test laboratory.

Using a programmable power supply the equipment under test was subjected to the detailed supply voltage dips and interruptions. The required supply phase synchronization and test repetition rate, detailed, was controlled by the programmable power supply. During this testing any anomalies in the equipment under tests performance was recorded.

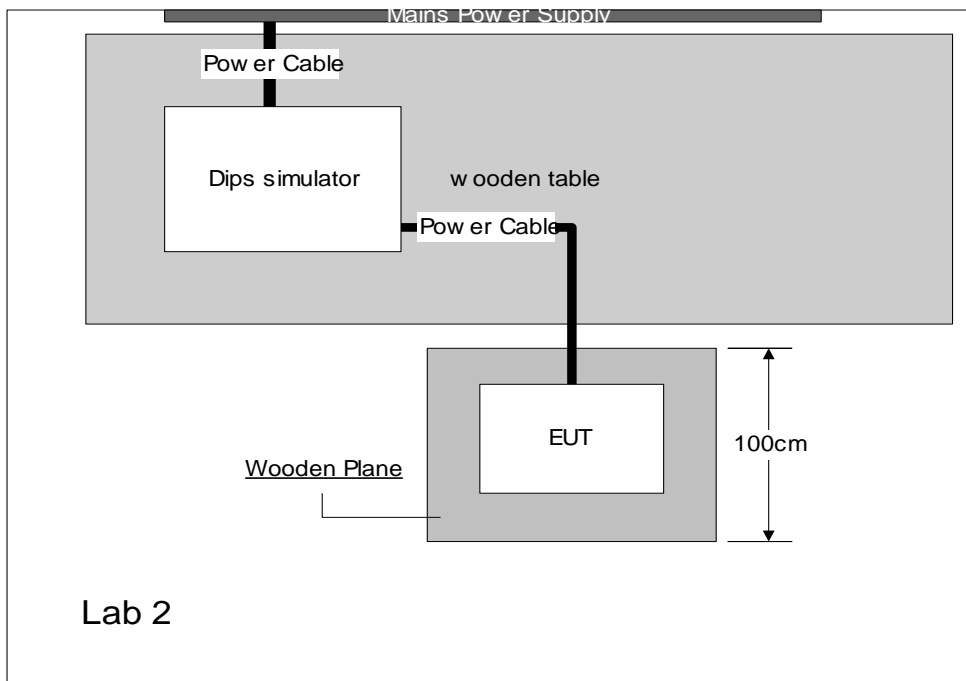

2.9.5 Environmental Conditions

Ambient Temperature	22.0 °C
Relative Humidity	55.0 %
Atmospheric Pressure	1008.0 mbar

2.9.6 Specification Limits

Voltage dips				
Voltage Dip in % Ut	Test level in % Ut	Duration		Performance Criteria
		50Hz	60Hz	
100	0	½ cycle	½ cycle	C
60	40	10 cycles	12 cycles	C
30	70	25 cycles	30 cycles	C
Ut is the rated voltage of the Equipment Under Test				

2.9.7 Test Results

Results for Configuration and Mode: Configuration1 and mode1

Performance assessment of the EUT made during this test: Pass.

Detailed results are shown below.

Tabulated Results for Voltage Dip and Short Interruption					
Line under test	Vnom	Operating Frequency	Test Level	Duration	Result
Power line	230 Vac	50 Hz	0% of Vnom	½ cycle	Pass PC A
Power line	230 Vac	50 Hz	40% of Vnom	10 cycles (50Hz)	Pass PC B
Power line	230 Vac	50 Hz	70% of Vnom	25 cycles (50Hz)	Pass PC B

Remark: During the tests of voltage dips 40% and 70% of Vnom, the speed of motor slows down, it can get right after removing the interference.



2.9.8 Test Location

This test was carried out in Immunity test location.

3 Test Equipment Information

3.1 General Test Equipment Used

Instrument	Manufacturer	Type No	TE No	Calibration Date	Calibration Due
Conducted Emission					
EMI Test Receiver	Rohde & Schwarz	ESHS30	707/639701	2020.05.11	2021.05.10
LISN	Schwarzbeck	NSLK8127	487/601428	2019.12.23	2020.12.22
Disturbance Power					
EMI Test Receiver	Rohde & Schwarz	ESCI3	487/631110	2020.05.11	2021.05.10
Absorbing Clamp	Rohde & Schwarz	MDS-21	487/601425	2019.12.23	2020.12.22
Harmonic and Flicker					
AC Power Supply Testing System	California Instruments	MX45-3PI	487/681243	2020.09.17	2021.09.16
Immunity					
ESD Simulator	HAEFELY	ONYX 30	487/751520	2020.09.17	2021.09.16
EFT/Burst Generator	EM test	UCS 500N5V	487/751218	2020.7.2	2021.7.1
Surge Generator	EM test	UCS 500N5E	487/751219	2020.7.2	2021.7.1
RF-Generator	Schaffner	NSG 2070	487/391121	2020.05.11	2021.05.10
Coupling/decoupling Network	TeseQ	CDN M016	487/571539	2020.05.11	2021.05.10
Voltage Drop Generator	EM test	UCS500N5-PFS	487/751117	2019.12.23	2020.12.22

4 Measurement Uncertainty

For a 95% confidence level, the measurement uncertainties for defined systems are:

Test Name	Measurement Uncertainty
Conducted Disturbance at Mains Terminals	150kHz to 30MHz, ± 3.09 dB
Disturbance power	30MHz to 300MHz, ± 3.32 dB
Harmonic current emission	The test was applied using proprietary equipment that meets the requirements of EN 61000-3-2.
Flicker	The test was applied using proprietary equipment that meets the requirements of EN 61000-3-3
Electrostatic discharge immunity test	The test was applied using proprietary equipment that meets the requirements of EN 61000-4-2
Electrical fast transient /burst immunity test	The test was applied using proprietary equipment that meets the requirements of EN 61000-4-4
Immunity to conducted disturbances, induced by radio-frequency fields	The test was applied using proprietary equipment that meets the requirements of EN 61000-4-6
Surge immunity test	The test was applied using proprietary equipment that meets the requirements of EN 61000-4-5
Voltage dips, short interruptions and voltage variations immunity tests	The test was applied using proprietary equipment that meets the requirements of EN 61000-4-11

5 Photographs



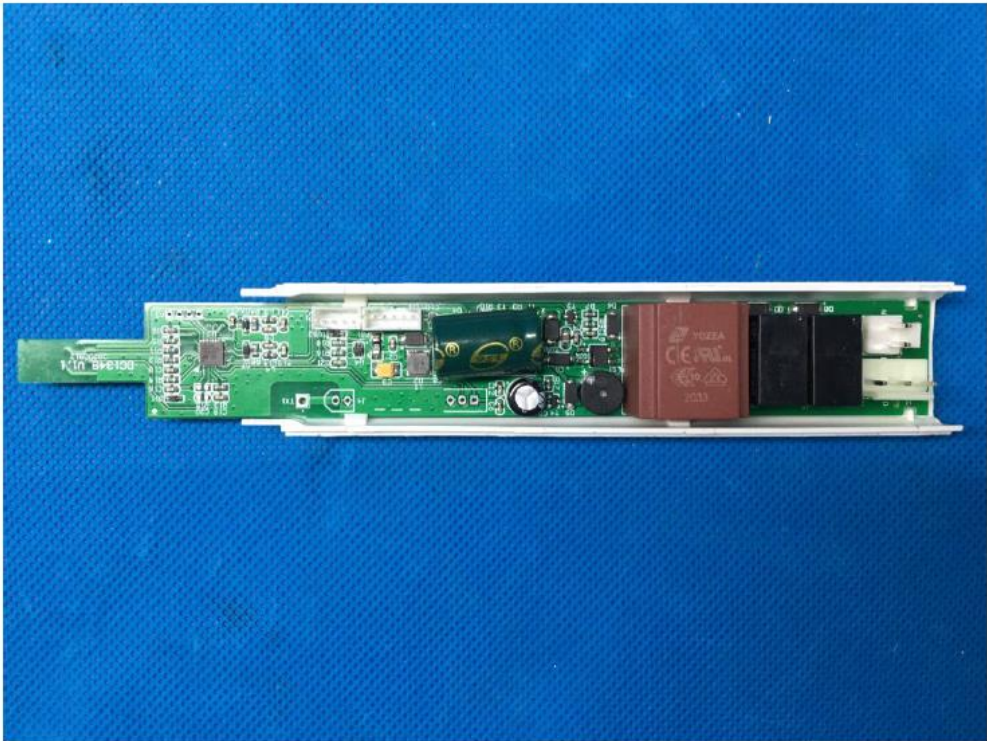
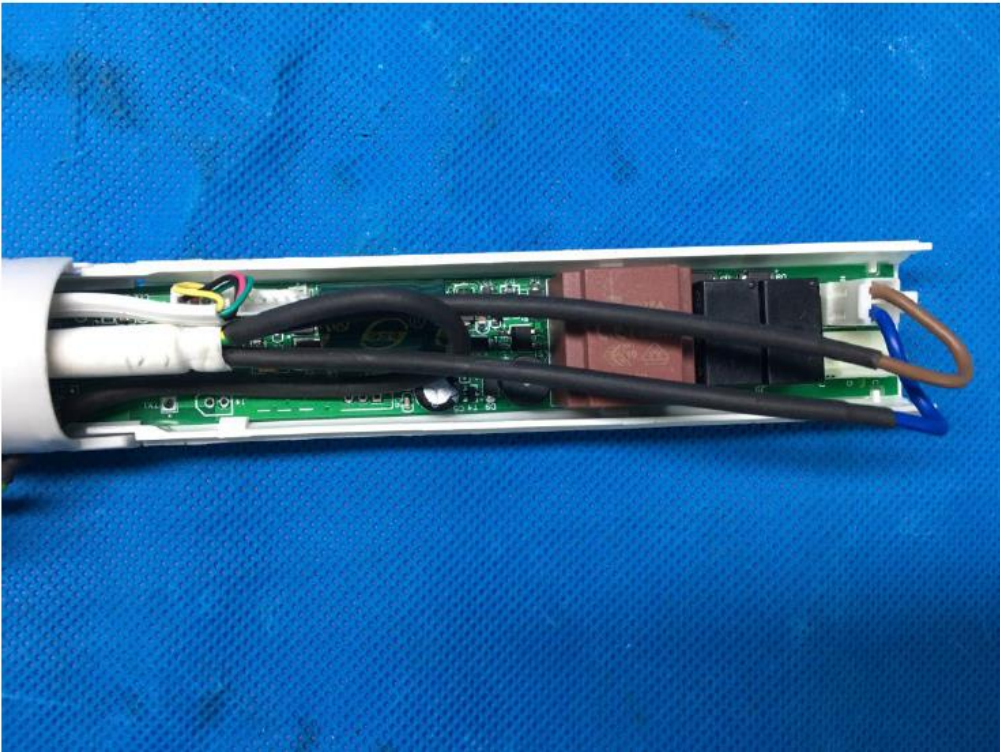



China

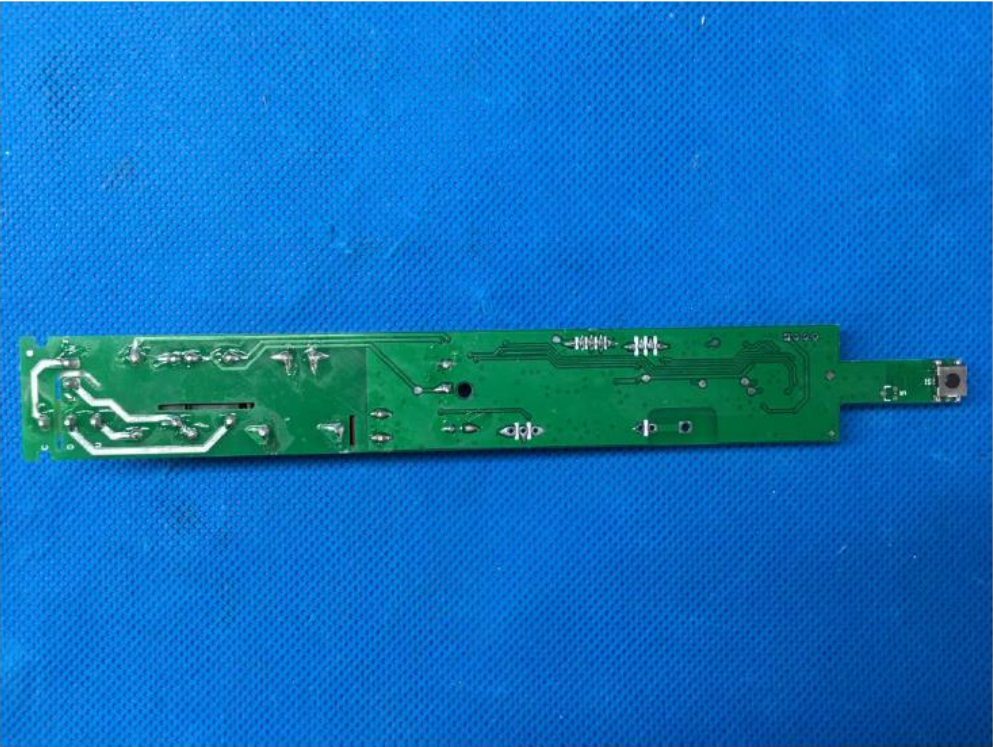
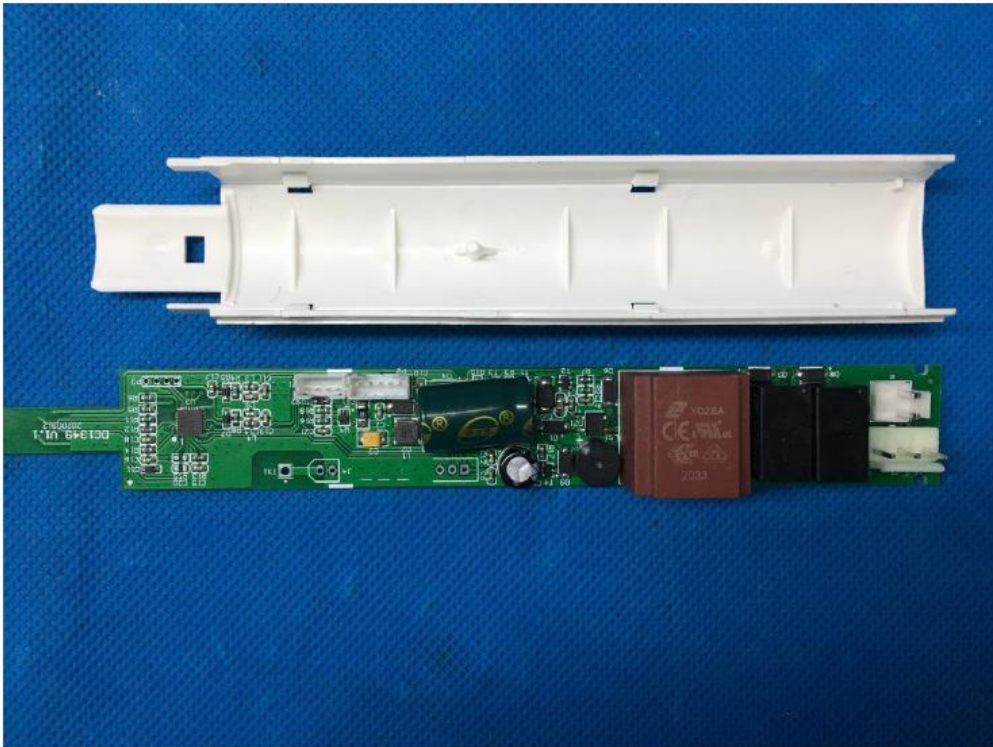



China

