

EMC Test Report

Applicant: Lumi United technology Co., Ltd.

Product: Smart Roller Shade controller

Model: SRSC-M01

In accordance with EN 301 489-1 and EN 301 489-17

Prepared for: Lumi United technology Co., Ltd.
8th Floor, JinQi Wisdom Valley, No.1 Tangling Road, Liuxian Ave, Taoyuan Residential District, Nanshan District, Shenzhen, China.





China

Add value.
Inspire trust.

COMMERCIAL-IN-CONFIDENCE

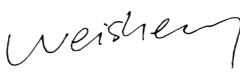
Report Number: 4840120503000B

RESPONSIBLE FOR	NAME	SIGNATURE	DATE
Approved By	Weisheng Jiang		2020. 11. 27
Prepared By	Zelin Gao		2020. 11. 27

Signatures in this approval box have checked this document in line with the requirements of TÜV SÜD Product Service control rules.

EXECUTIVE SUMMARY

A sample of this product was tested and found to be in compliant with EN 301 489-1: V2.2.3:2019, EN 301 489-17 V3.2.4:2020.

DISCLAIMER AND COPYRIGHT

This non-binding report has been prepared by TÜV SÜD Product Service with all reasonable skill and care. The reports apply only to the specific samples tested under stated test conditions. The document is confidential to the potential Client and TÜV SÜD Product Service. No part of this document may be reproduced without the prior written approval of TÜV SÜD Product Service.



Contents

1	Report Summary	3
1.1	Report Modification Record.....	3
1.2	Introduction.....	3
1.3	Brief Summary of Results	4
1.4	Product Information.....	5
1.5	Deviations from the Standard.....	6
1.6	Test Location.....	6
2	Test Details	7
2.1	Radiated Emissions (Enclosure Port)	7
2.2	Conducted Emissions (AC Power Port)	14
2.3	Immunity to Radio Frequency Electromagnetic Field (Enclosure Port)	21
2.4	Immunity to Electrostatic Discharge (Enclosure Port).....	24
2.5	Immunity to Fast Transients (AC Power Port).....	27
2.6	Immunity to Radio Frequency (AC Power Port)	30
2.7	Immunity to Voltage dips and interruptions (AC Power Port)	33
2.8	Immunity to Surges (AC Power Port)	36
2.9	Harmonic current emission	39
2.10	Flicker	44
3	Test Equipment Information	47
3.1	General Test Equipment Used.....	47
4	Measurement Uncertainty	49
5	Photographs	50



1 Report Summary

1.1 Report Modification Record

Alterations and additions to this report will be issued to the holders of each copy in the form of a complete document.

Issue	Description of Change	Date of Issue
1	First Issue	27/11/2020

1.2 Introduction

The information contained in this report is intended to show verification of the EMC Qualification Approval Testing of the requirements of the standards for the tests listed in Section 1.3.

Applicant	Lumi United technology Co., Ltd.
address	8th Floor, JinQi Wisdom Valley, No.1 Tangling Road, Liuxian Ave, Taoyuan Residential District, Nanshan District, Shenzhen, China.
Manufacturer	Lumi United technology Co., Ltd.
address	8th Floor, JinQi Wisdom Valley, No.1 Tangling Road, Liuxian Ave, Taoyuan Residential District, Nanshan District, Shenzhen, China.
Factory	Ningbo Dooya Mechanic & Electronic Technology Co., Ltd
address	No.168 Shengguang Road, Luotuo, Zhenghai, 315202 Ningbo, Zhejiang Province, People's Republic of China
Model Number(s)	SRSC-M01
Sample No.	522559
Ratings	220-230V~, 50Hz, 121W,0.53A
Number of Samples Tested	1
Test Specification	EN 301 489-1: V2.2.3: 2019 EN 301 489-17 V3.2.4:2020
Date of Receipt of EUT	24/10/2020
Start of Test	25/10/2020
Finish of Test	28/10/2020
Name of Engineer(s)	Zelin Gao, Xin Feng

1.3 Brief Summary of Results

A brief summary of the tests carried out in accordance with EN 301 489-1 is shown below.

Section	Specification	Clause	Test Description	Result	Comments/Base Standard
AC Powered power on					
2.1	EN 301 489-1	8.2	Radiated Emissions (Enclosure Port)	Pass	
2.2	EN 301 489-1	8.4	Conducted Emissions (AC Power Port)	Pass	EN 55032
2.3	EN 301 489-1	9.2	Immunity to Radio Frequency Electromagnetic Field	Pass	EN 61000-4-3
2.4	EN 301 489-1	9.3	Immunity to Electrostatic Discharge	Pass	EN 61000-4-2
2.5	EN 301 489-1	9.4	Immunity to Fast Transients, Common Mode	Pass	EN 61000-4-4
2.6	EN 301 489-1	9.5	Immunity to Radio Frequency, Common Mode	Pass	EN 61000-4-6
2.7	EN 301 489-1	9.7	Immunity to Voltage dips and interruptions	Pass	EN 61000-4-11
2.8	EN 301 489-1	9.8	Immunity to Surges	Pass	EN 61000-4-5
2.9	EN 301 489-1	8.5	Harmonic current emissions	Pass	
Switch on/off					
2.10	EN 301 489-1	8.6	Voltage fluctuations and flicker	Pass	



1.4 Product Information

1.4.1 Technical Description

The Equipment Under Test (EUT) was a Smart Roller Shade controller

1.4.2 EUT Port/Cable Identification

Port	Max Cable Length specified	Usage	Type	Screened
Power on				
AC Power port	1m	Power line	3 core	No

1.4.3 Test Configuration

Configuration	Description
1:AC Powered	230V AC 50Hz

1.4.4 Modes of Operation

Mode	Description
1: Power on	Normal working with Zigbee communication
2: switch on/off	The EUT was switch on/off

1.4.5 Monitoring of Performance

The EUT works normally

1.4.6 Performance Criteria

Functional tests before, during and after the immunity tests were performed in order to verify compliance with the Performance criterion in section 6 of EN 301 489-17.

Performance criteria A

During immunity tests, the test object shall operate as intended with no loss of function, and no unintentional transmissions.

After each test case the test object shall operate as intended, with no loss of function, no degradation of performance, no loss of stored data or user programmable functions.

Performance criteria B

During immunity tests, the test object may be loss of function (one or more) and degradation of performance, with no unintentional transmissions.



After each test case the test object shall operate as intended, lost function(s) shall be self-recoverable, with no degradation of performance, no loss of stored data or user programmable functions.

1.5 Deviations from the Standard

No deviations from the applicable test standard were made during testing.

1.6 Test Location

TÜV SÜD Product Service conducted the following tests at TÜV SÜD Certification and Testing (China) Co., Ltd.

Address:

No. 10 Huaxia Road (M)
 Dongting
 Wuxi
 Jiangsu Province
 214100
 China

Test Name	Name of Engineer(s)
AC Powered	
Conducted Disturbance at Mains Terminals	Xin Feng
Radiated Emissions	Xin Feng
Electrostatic discharge immunity test	Xin Feng
Electrical fast transient /burst immunity test	Xin Feng
Immunity to conducted disturbances, induced by radio-frequency fields	Xin Feng
Radiated, radio-frequency, electromagnetic field immunity test	Xin Feng
Surge immunity test	Xin Feng
Voltage dips, short interruptions and voltage variations immunity tests	Xin Feng
Harmonic Current Emissions	Xin Feng
switch on/off	
Flicker	Xin Feng

2 Test Details

2.1 Radiated Emissions (Enclosure Port)

2.1.1 Specification Reference

EN 301 489-1 V2.2.3: 2019, Clause 8.

2.1.2 Equipment Under Test

SRSC-M01

2.1.3 Date of Test

28/10/2020

2.1.4 Test Method

The EUT was set up in a semi-anechoic chamber on a remotely controlled turntable and placed on a non-conductive table 0.8m above a reference ground plane. A prescan of the EUT emissions profile was made while varying the antenna-to-EUT azimuth and antenna-to-EUT polarization using a peak (average) detector; measurements were taken at a 10m (3m) distance. Using the prescan list of the highest emissions detected, their bearing and associated antenna polarization, the EUT was then formally measured using a Quasi-Peak detector. The readings were maximized by adjusting the antenna height, polarization and turntable azimuth, in accordance with the specification.

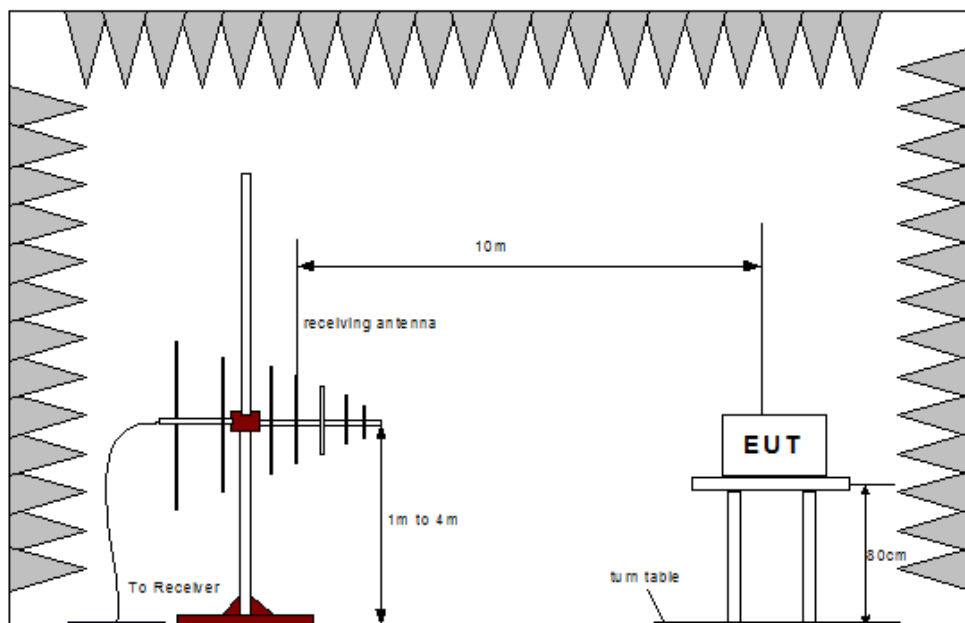

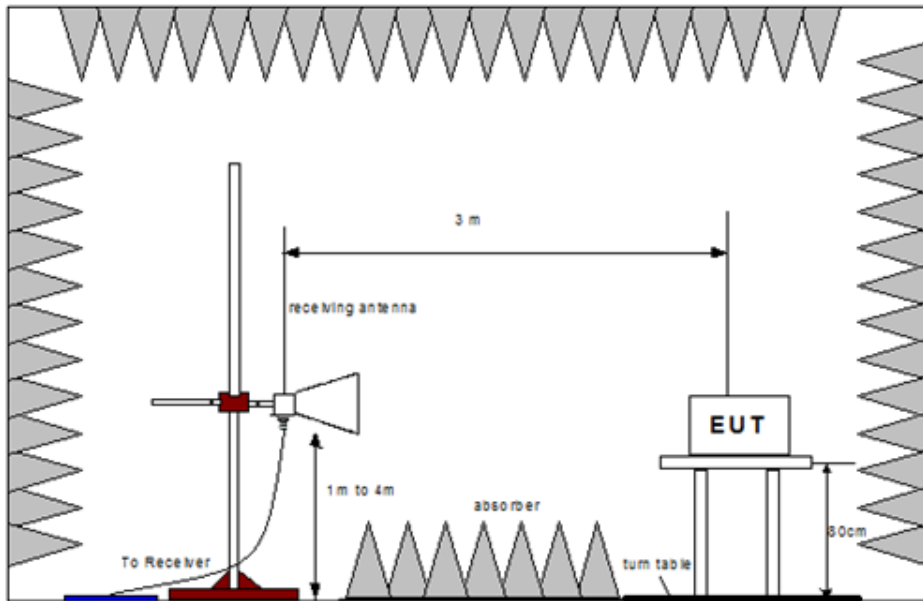

2.1.5 Environmental Conditions

Ambient Temperature 22.0 °C
 Relative Humidity 55.0 %
 Atmospheric Pressure 1012.0 mbar

2.1.6 Specification Limits

Radiated disturbance limits in the frequency range 30MHz to 1000MHz at a measuring distance of 10 m	
Frequency range MHz	Quasi-peak limits dB(µV/m)
30 to 230	30
230 to 1000	37

Required Specification Limits (Class B @ 3m)		
Frequency Range (MHz)	Average (dBµV/m)	Peak (dBµV/m)
1000 to 3000	50	70
3000 to 6000	54	74

2.1.7 Test Results

Results for Configuration and Mode: Configuration1 and mode1

Performance assessment of the EUT made during this test: Pass.

Detailed results are shown below:



30MHz-1000MHz Radiated Emission Test

SRSC-M01

EUT: Smart Roller Shade controller
 Manufacturer: lumi
 Operating Condition: Power on
 Test Site: TUV 10m Chamber
 Operator: Xin Feng
 Test Specification: EN 55032 CLASSB
 Comment1: Horizontal
 Comment2: Sample No:522559

SCAN TABLE: "EN 55032 CLASS B"

Short Description:		Field Strength QP Limit				
Start	Stop	Step	Detector	Meas. Time	IF Bandw.	Transducer
Frequency	Frequency	Width				
30.0 MHz	1.0 GHz	50.0 kHz	MaxPeak	1.0 ms	120 kHz	310N2020

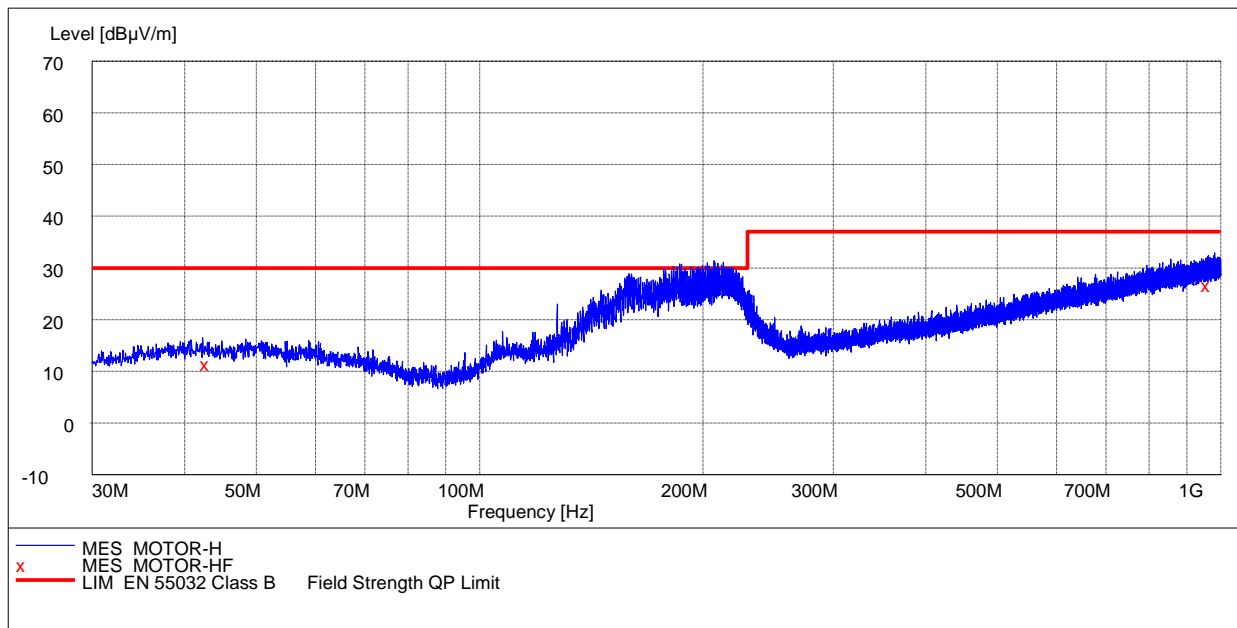

MEASUREMENT RESULT: "MOTOR-HF"

Frequency	Level
MHz	dBµV/m
42.900000	11.73
186.050000	27.79
202.850000	28.23
207.500000	28.35
213.150000	28.72
962.150000	27.04



30MHz-1000MHz Radiated Emission Test

SRSC-M01

EUT: Smart Roller Shade controller
 Manufacturer: lumi
 Operating Condition: Power on
 Test Site: TUV 10m Chamber
 Operator: Xin Feng
 Test Specification: EN 55032 CLASSB
 Comment1: Vertical
 Comment2: Sample No:522559

SCAN TABLE: "EN 55032 CLASS B"

Short Description:		Field Strength QP Limit				
Start	Stop	Step	Detector	Meas. Time	IF Bandw.	Transducer
Frequency	Frequency	Width				
30.0 MHz	1.0 GHz	50.0 kHz	MaxPeak	1.0 ms	120 kHz	310N2020

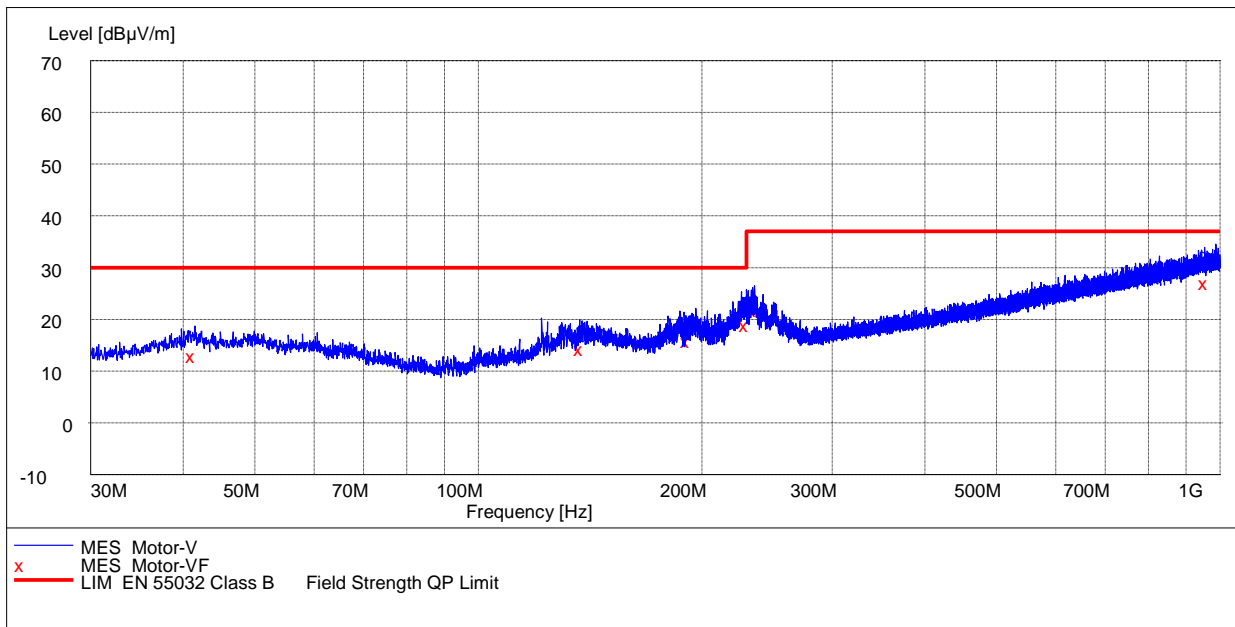

MEASUREMENT RESULT: "Motor-VF"

Frequency	Level
MHz	dBµV/m
41.250000	13.40
137.550000	14.69
191.450000	16.27
229.650000	19.32
235.450000	22.18
957.250000	27.40

Data sheet:

Test Description: 1-6GHz Radiated Emission Test
 Operating Conditions: power on, AC 230V 50Hz
 Operator Name: Xin Feng
 Comment: Horizontal
 Sample No: 522559

Subrange 1

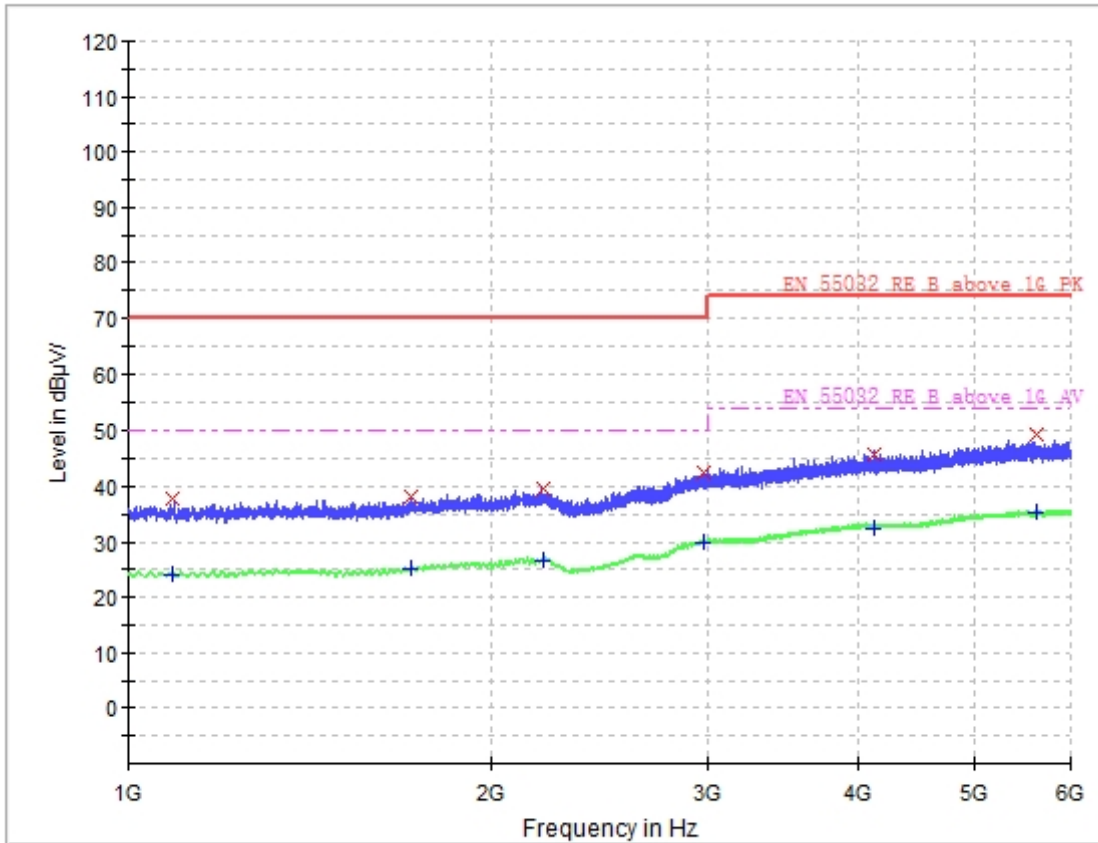

Result

Frequency (MHz)	MaxPeak (dBµV/m)	Average (dBµV/m)	Margin - AVG (dB)	Limit - AVG (dBµV/m)	Margin - PK+ (dB)	Limit - PK+ (dBµV/m)
1086.500000	37.7	24.2	25.8	50.0	32.3	70.0
1713.500000	38.0	25.0	25.0	50.0	32.0	70.0
2199.000000	39.6	26.6	23.5	50.0	30.4	70.0
2979.500000	42.6	29.8	20.2	50.0	27.4	70.0
4132.000000	45.9	32.4	21.6	54.0	28.1	74.0
5625.500000	49.3	35.4	18.6	54.0	24.7	74.0

Data sheet:

Test Description: 1-6GHz Radiated Emission Test
 Operating Conditions: power on, AC 230V 50Hz
 Operator Name: Xin Feng
 Comment: Vertical
 Sample No: 522559

Subrange 1

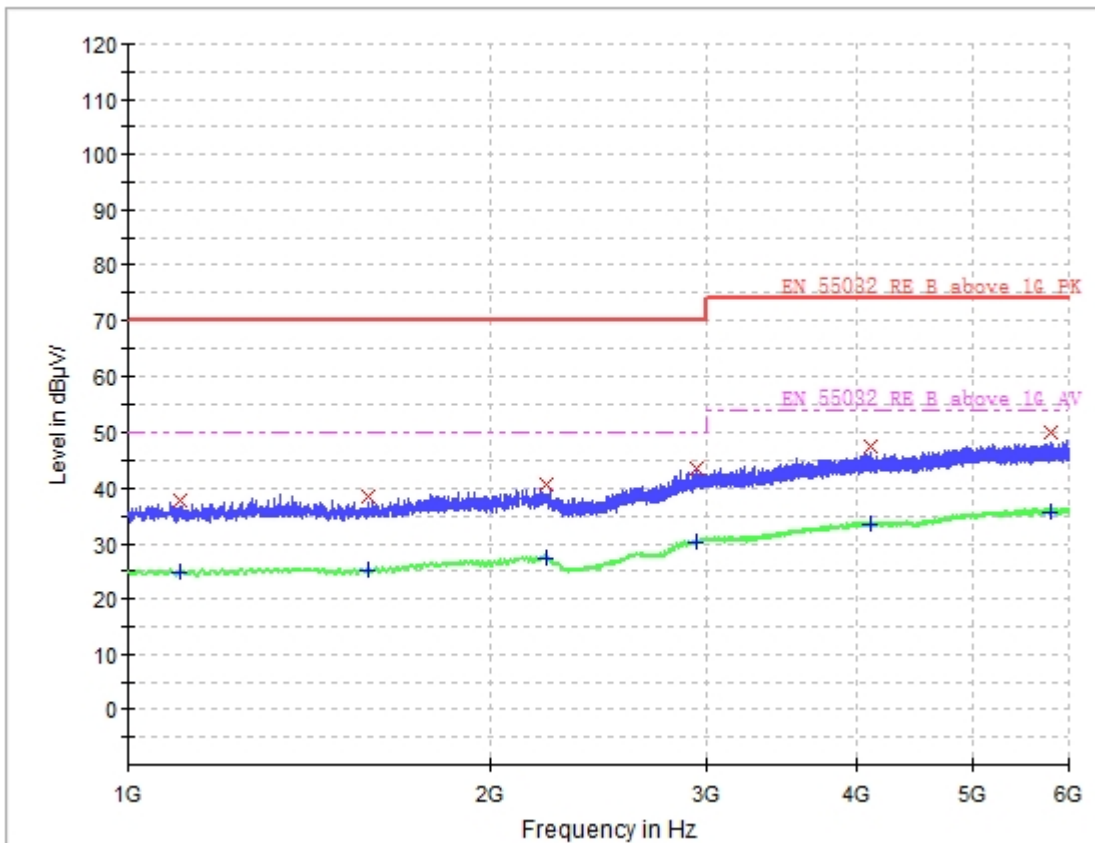

Result

Frequency (MHz)	MaxPeak (dBµV/m)	Average (dBµV/m)	Margin - AVG (dB)	Limit - AVG (dBµV/m)	Margin - PK+ (dB)	Limit - PK+ (dBµV/m)
1106.500000	37.8	24.7	25.3	50.0	32.2	70.0
1582.500000	38.7	25.1	24.9	50.0	31.3	70.0
2217.500000	40.6	27.2	22.8	50.0	29.4	70.0
2953.000000	43.5	30.1	19.9	50.0	26.5	70.0
4105.000000	47.5	33.3	20.7	54.0	26.5	74.0
5788.500000	50.0	35.8	18.2	54.0	24.0	74.0

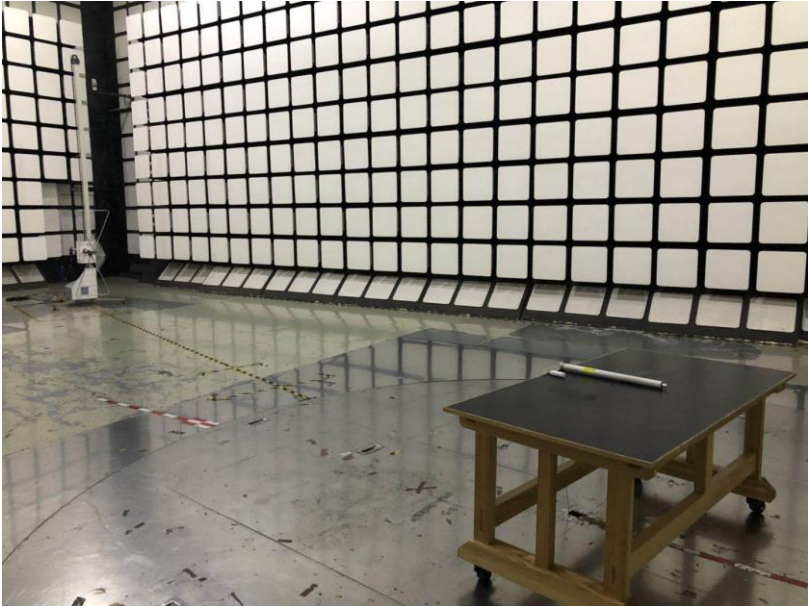

Test Setup(30 MHz -1000MHz)

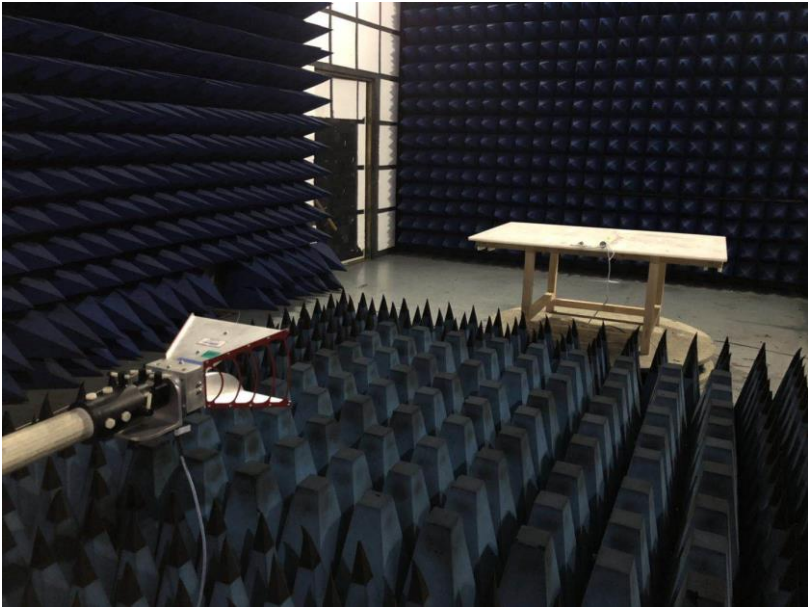

Test Setup(1000 MHz -6000MHz)

2.1.8 Test Location

This test was carried out in 10m anechoic chamber and 3m anechoic.

2.2 Conducted Emissions (AC Power Port)

2.2.1 Specification Reference

EN 301 489-1 V2.2.3: 2019, Clause 8.4

2.2.2 Equipment Under Test

SRSC-M01

2.2.3 Date of Test

28/10/2020

2.2.4 Test Method

The EUT was placed on a non-conductive table 0.1m above a reference ground plane. All power was connected to the EUT through an Artificial Mains Network (AMN). Conducted disturbance voltage measurements on mains lines were made at the output of the AMN. The AMN was placed 0.8m from the boundary of the EUT and bonded to the reference ground plane.

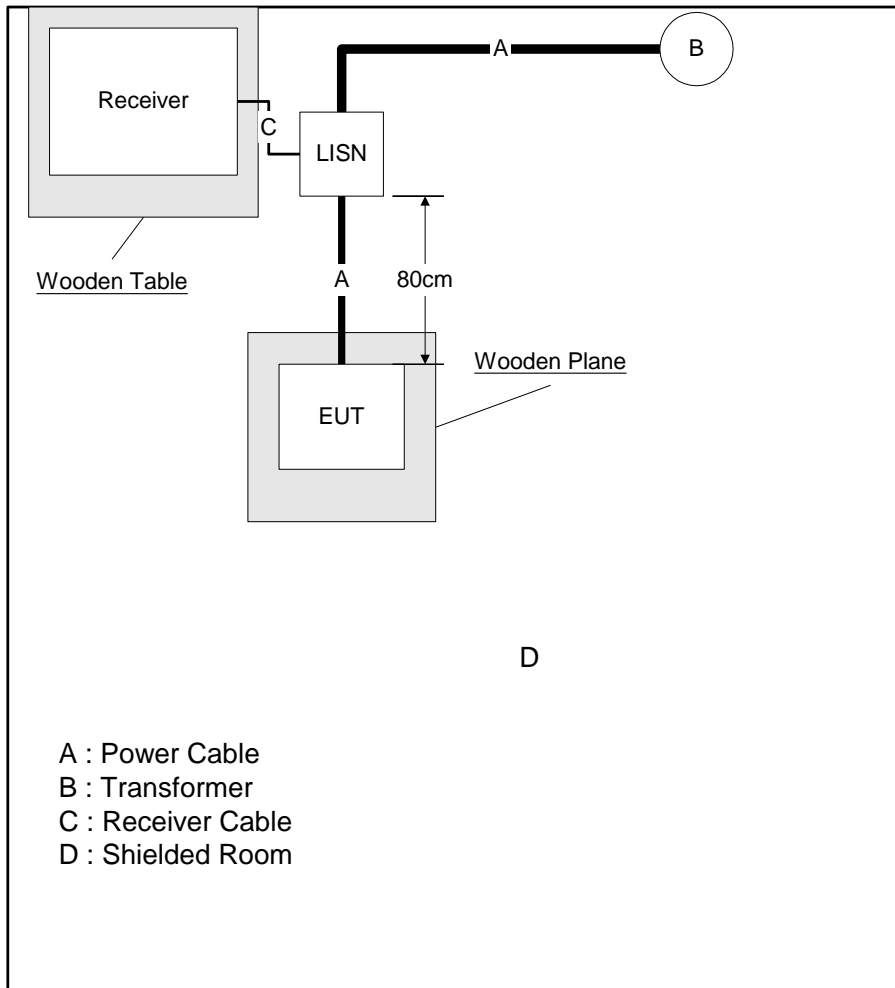

2.2.5 Environmental Conditions

Ambient Temperature 25.0 °C
 Relative Humidity 51.0 %
 Atmospheric Pressure 1012.0 mbar

2.2.6 Specification Limits

Required Specification Limits (Class B)			
Line Under Test	Frequency Range (MHz)	Quasi-peak (dBµV)	Average (dBµV)
AC Power Port	0.15 to 0.5	66 to 56	56 to 46
	0.5 to 5	56	46
	5 to 30	60	50
Supplementary information:			
Note 1. EUT powered at one of the Nominal input voltages and frequencies			

2.2.7 Test Results

Results for Configuration and Mode: Configuration1 and mode1
 Performance assessment of the EUT made during this test: Pass.
 Detailed results are shown below.



**150kHz-30MHz Conducted Emission Test
SRSC-M01**

EUT: Smart Roller Shade controller
 Manuf: Lumi United technology Co., Ltd.
 Op Cond: Power on, AC 230V 50Hz
 Operator: Xin Feng
 Test Spec: EN 55032 Class B
 Comment: Phase L
 Sample No.: 522559
 Result File: CE-L.dat : New Measurement

Scan Settings (2 Ranges)				Receiver Settings				
Start	Stop	Step	IF BW	Detector	M-Time	Atten	Preamp	OpRge
150kHz	1000kHz	5kHz	10kHz	PK+AV	20msec	Auto	OFF	60dB
1000kHz	30MHz	10kHz	10kHz	PK+AV	20msec	Auto	OFF	60dB

Transducer	No.	Start	Stop	Name
	1	9kHz	30MHz	NSLK8127

Final Measurement: Detectors: X QP / + AV
 Meas Time: 1sec
 Subranges: 16
 Acc Margin: 8 dB

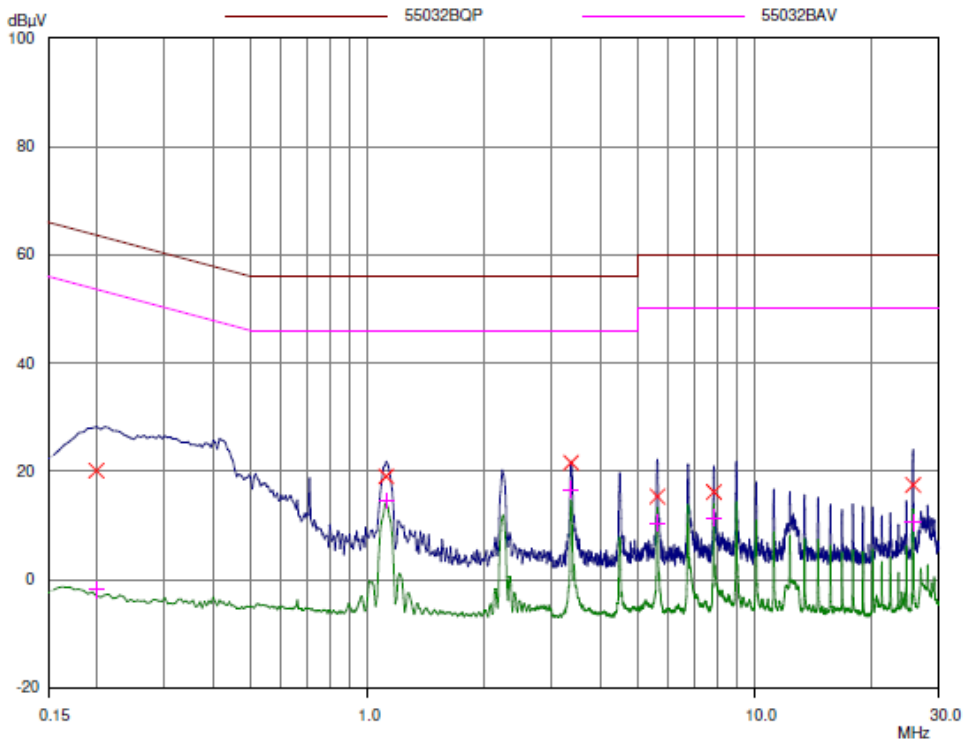



**150kHz-30MHz Conducted Emission Test
SRSC-M01**

EUT: Smart Roller Shade controller
 Manuf: Lumi United technology Co., Ltd.
 Op Cond: Power on, AC 230V 50Hz
 Operator: Xin Feng
 Test Spec: EN 55032 Class B
 Comment: Phase L
 Sample No.:522559
 Result File: CE-L.dat : New Measurement

Scan Settings (2 Ranges)

Frequencies			Receiver Settings					
Start	Stop	Step	IF BW	Detector	M-Time	Atten	Preamp	OpRge
150kHz	1000kHz	5kHz	10kHz	PK+AV	20msec	Auto	OFF	60dB
1000kHz	30MHz	10kHz	10kHz	PK+AV	20msec	Auto	OFF	60dB

Transducer	No.	Start	Stop	Name
	1	9kHz	30MHz	NSLK8127

Final Measurement: Detectors: X QP / + AV
 Meas Time: 1sec
 Subranges: 16
 Acc Margin: 8 dB

Final Measurement Results

Frequency MHz	QP Level dBµV	QP Limit dBµV	QP Delta dB
0.2	20.09	63.61	43.52
1.12	19.05	56.00	36.95
3.36	21.57	56.00	34.43
5.61	15.33	60.00	44.67
7.85	16.17	60.00	43.83
25.68	17.44	60.00	42.56

Frequency MHz	AV Level dBµV	AV Limit dBµV	AV Delta dB
0.2	-1.96	53.61	55.57
1.12	14.52	46.00	31.48
3.36	16.66	46.00	29.34
5.61	10.40	50.00	39.60
7.85	11.41	50.00	38.59
25.68	10.48	50.00	39.52

**150kHz-30MHz Conducted Emission Test
SRSC-M01**

EUT: Smart Roller Shade controller
 Manuf: Lumi United technology Co., Ltd.
 Op Cond: Power on, AC 230V 50Hz
 Operator: Xin Feng
 Test Spec: EN 55032 Class B
 Comment: Phase N
 Sample No.: 522559
 Result File: CE-N.dat : New Measurement

Scan Settings (2 Ranges)				Receiver Settings				
Start	Stop	Step	IF BW	Detector	M-Time	Atten	Preamp	OpRge
150kHz	1000kHz	5kHz	10kHz	PK+AV	20msec	Auto	OFF	60dB
1000kHz	30MHz	10kHz	10kHz	PK+AV	20msec	Auto	OFF	60dB

Transducer	No.	Start	Stop	Name
	1	9kHz	30MHz	NSLK8127

Final Measurement:	Detectors:	X QP / + AV
	Meas Time:	1sec
	Subranges:	16
	Acc Margin:	8 dB

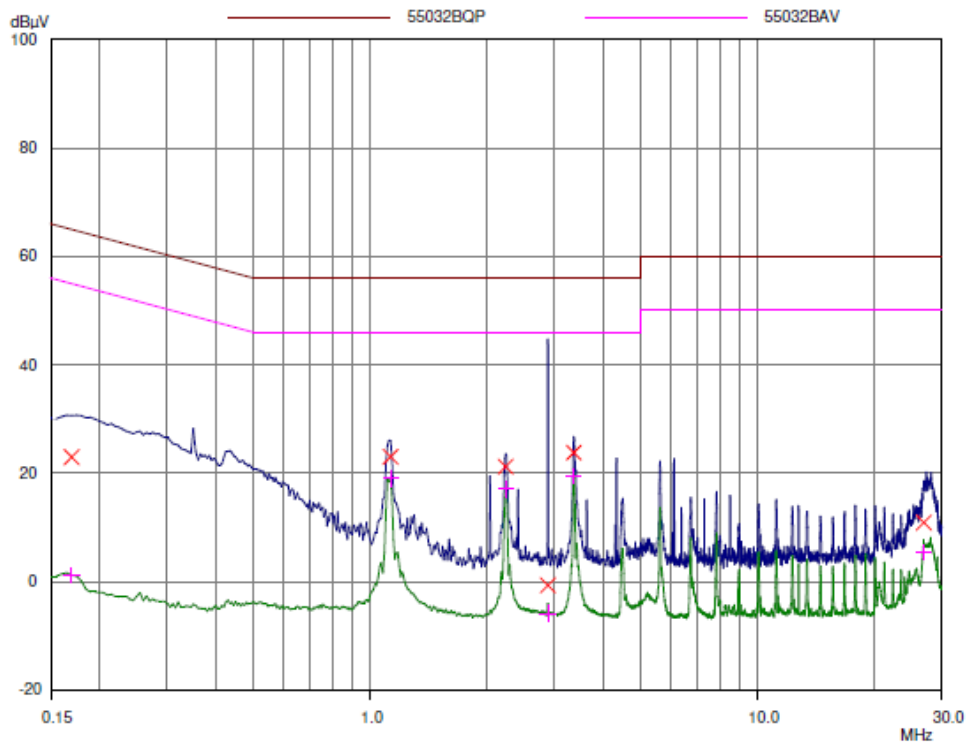



150kHz-30MHz Conducted Emission Test

SRSC-M01

EUT: Smart Roller Shade controller
 Manuf: Lumi United technology Co., Ltd.
 Op Cond: Power on, AC 230V 50Hz
 Operator: Xin Feng
 Test Spec: EN 55032 Class B
 Comment: Phase N
 Sample No.:522559
 Result File: CE-N.dat : New Measurement

Scan Settings (2 Ranges)

Frequencies				Receiver Settings					
Start	Stop	Step	IF BW	Detector	M-Time	Atten	Preamp	OpRge	
150kHz	1000kHz	5kHz	10kHz	PK+AV	20msec	Auto	OFF	60dB	
1000kHz	30MHz	10kHz	10kHz	PK+AV	20msec	Auto	OFF	60dB	

Transducer	No.	Start	Stop	Name
	1	9kHz	30MHz	NSLK8127

Final Measurement: Detectors: X QP / + AV
 Meas Time: 1sec
 Subranges: 16
 Acc Margin: 8 dB

Final Measurement Results

Frequency MHz	QP Level dBµV	QP Limit dBµV	QP Delta dB
0.17	22.95	64.96	42.01
1.13	23.03	56.00	32.97
2.24	21.18	56.00	34.82
2.88	-0.72	56.00	56.72
3.36	23.79	56.00	32.21
26.89	10.85	60.00	49.15

Frequency MHz	AV Level dBµV	AV Limit dBµV	AV Delta dB
0.17	1.23	54.96	53.73
1.13	18.99	46.00	27.01
2.24	17.03	46.00	28.97
2.88	-5.89	46.00	51.89
3.36	19.37	46.00	26.63
26.89	5.38	50.00	44.62

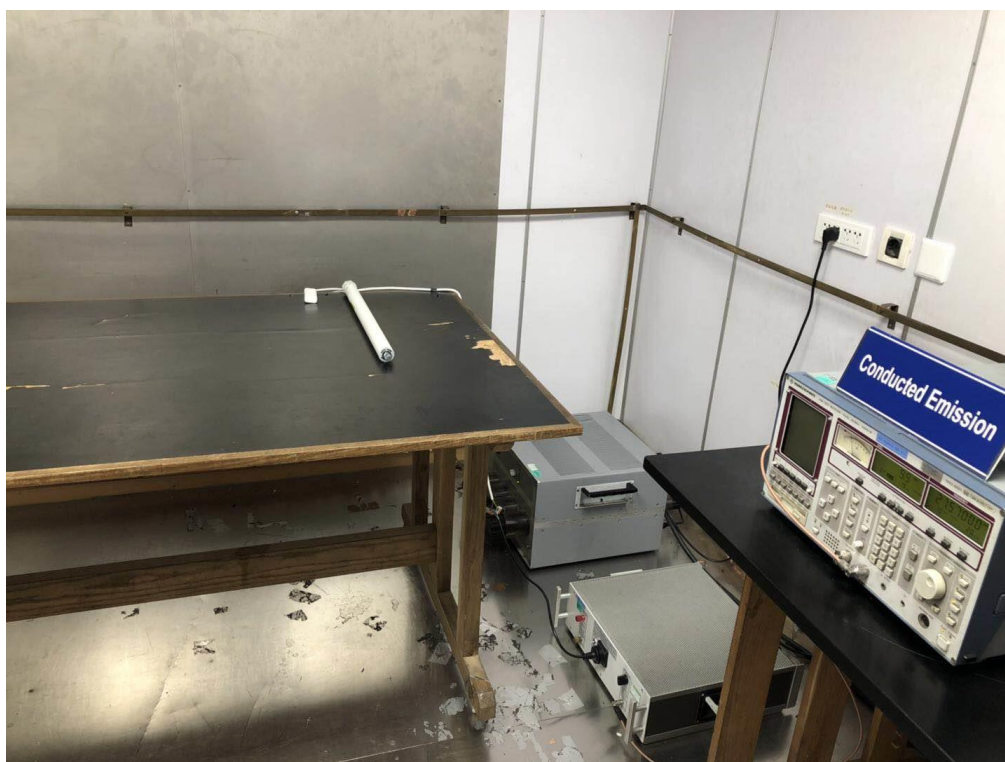

Test Setup

2.2.8 Test Location

This test was carried out in shielded room C.

2.3 Immunity to Radio Frequency Electromagnetic Field (Enclosure Port)

2.3.1 Specification Reference

EN 301 489-1 V2.2.3:2019, Clause 9.2

2.3.2 Equipment Under Test

SRSC-M01

2.3.3 Date of Test

27/10/2020

2.3.4 Test Method

The equipment under test including associated cabling was configured, on a 0.8 m non-conductive table for table-top equipment and on a 0.1 m insulated support for floor standing equipment; with a pre-calibrated semi anechoic chamber.

All four side of the equipment under test were subjected to the required RF field strength, modulated as described, swept over the frequency range of test with the antenna positioned in both horizontal and vertical polarizations.

During this testing any anomalies in the equipment under tests performance was recorded.

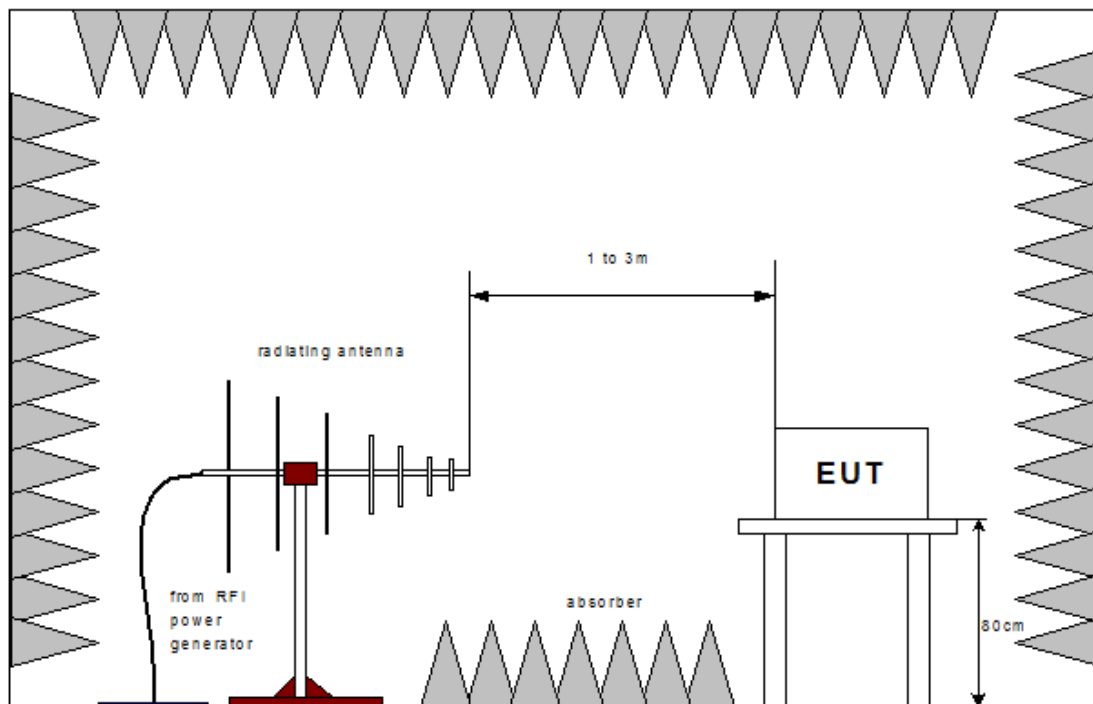



2.3.5 Environmental Conditions

Ambient Temperature 22.0 °C
 Relative Humidity 54.0 %
 Atmospheric Pressure 1012.0 mbar

2.3.6 Specification Limits

Required Test Levels					Performance Criteria
Frequency Range (MHz)	Level (V/m)	Modulation	Step Size (%)	Dwell (s)	
80 to 6000	3	AM (80 %, 1 kHz, sine wave)	1	<3>	A
Supplementary information:					
Note 1. EUT powered at one of the Nominal input voltages and frequencies					
Note 2. If the wanted signal is modulated at 1 000 Hz, then an audio signal of 400 Hz shall be used					

2.3.7 Test Results

Results for Configuration and Mode: Configuration1 and mode1

Performance assessment of the EUT made during this test: Pass.

Detailed results are shown below.

Tabulated Results for RF Electromagnetic Field 80 - 6000 MHz				
Side of the equipment under test	Antenna polarization	Test Level	Dwell Time	Result
Front	horizontal	3 V/m	3 s	Pass PC A
Front	vertical	3 V/m	3 s	Pass PC A
Rear	horizontal	3 V/m	3 s	Pass PC A
Rear	vertical	3 V/m	3 s	Pass PC A
Left	horizontal	3 V/m	3 s	Pass PC A
Left	vertical	3 V/m	3 s	Pass PC A
Right	horizontal	3 V/m	3 s	Pass PC A
Right	vertical	3 V/m	3 s	Pass PC A

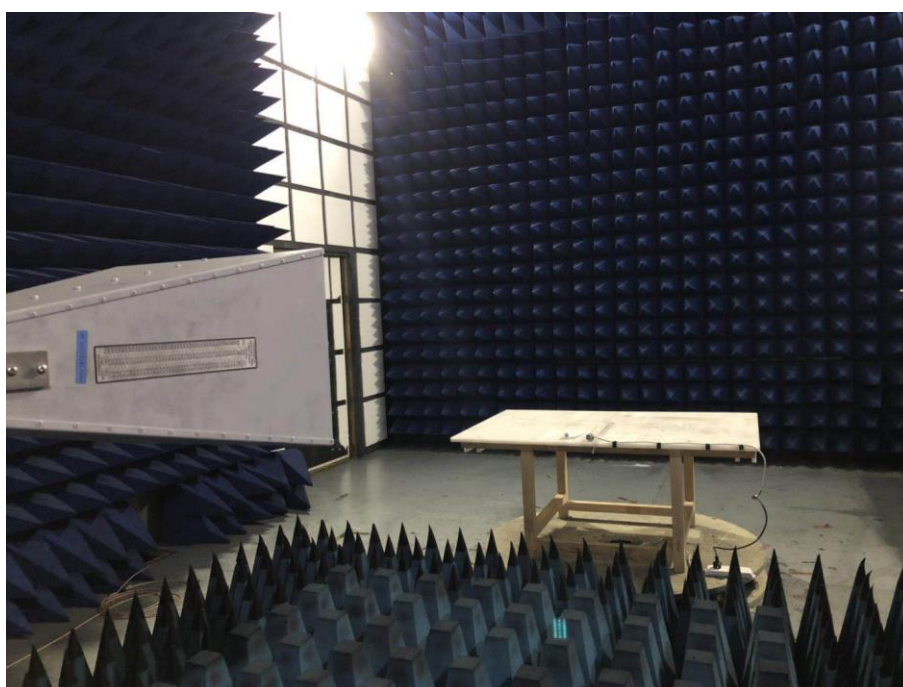

Test Setup

2.3.8 Test Location

This test was carried out in 3m anechoic chamber.

2.4 Immunity to Electrostatic Discharge (Enclosure Port)

2.4.1 Specification Reference

EN 301 489-1 V2.2.3: 2019, Clause 9.3

2.4.2 Equipment Under Test

SRSC-M01

2.4.3 Date of Test

27/10/2020

2.4.4 Test Method

The equipment under test including associated cabling was configured on but insulated from, using a 0.5mm isolator, a horizontal coupling plane fitted to the top of a 0.8m non-conductive table for table-top equipment; and on a 0.1m insulated support for floor standing equipment; above a ground reference plane all within a test laboratory.

Using the air discharge method for non-metallic parts, contact discharge method for metallic parts with both vertical and horizontal couple plane discharge methods for the sides of the equipment under test, the required electrostatic discharge voltage levels in both voltage polarities were applied at the detailed pulse repartition rate.

During this testing any anomalies in the equipment under tests performance was recorded.

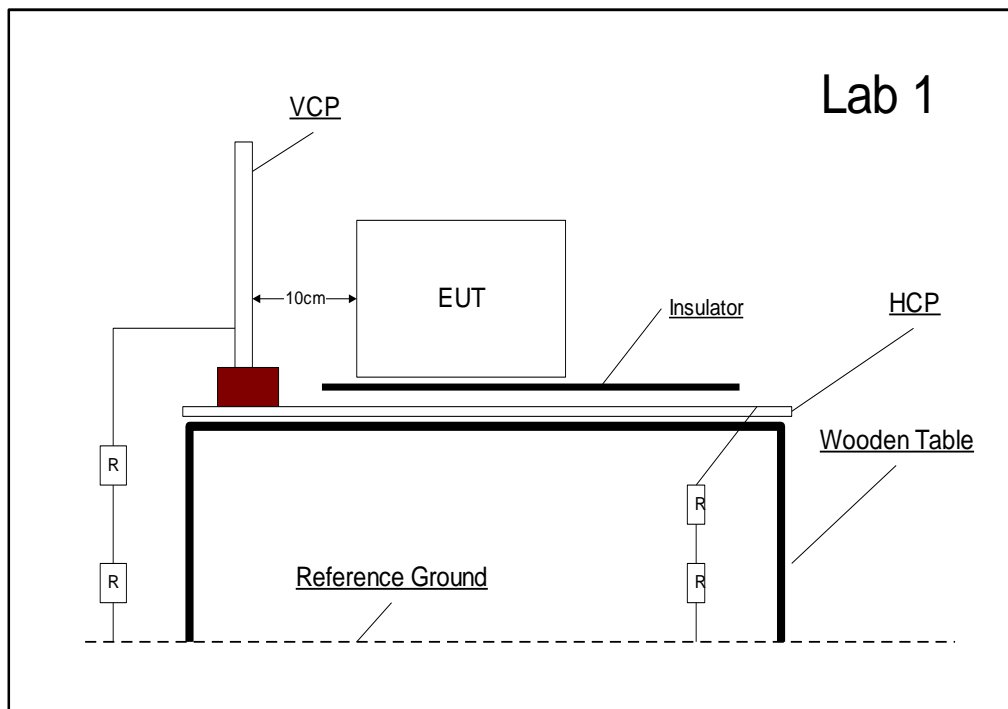



2.4.5 Environmental Conditions

Ambient Temperature 21.0 °C
 Relative Humidity 52.0 %
 Atmospheric Pressure 1009.0 mbar

2.4.6 Specification Limits

Required Test Levels				Performance Criteria
Discharge type	Discharge Level (kV)		Number of discharges per location (each polarity)	
	Positive	Negative		
Air – Direct	2, 4 and 8	2, 4 and 8	<10>	B
Contact – Direct	2 and 4	2 and 4	<10>	B
Contact – Indirect	2 and 4	2 and 4	<10>	B

2.4.7 Test Results

Results for Configuration and Mode: Configuration1 and mode1

Performance assessment of the EUT made during this test: Pass.

Detailed results are shown below.

ID	Test Point	Discharge	Results									
			2kV		4kV		6kV		8kV		15kV	
			+	-	+	-	+	-	+	-	+	-
	VCP/HCP/Enclosure	Contact	✓	✓	✓	✓						
	Case	Air	✓	✓	✓	✓			✓	✓		

Key to Results	
✓	The EUTs performance was not impacted when the ESD pulse was applied.
✓*	No discharge occurred at this point when the ESD pulse was applied
Ox	
Fx	
N/A	Not Appliance



Test Setup

2.4.8 Test Location

This test was carried out in shielded room D.

2.5 Immunity to Fast Transients (AC Power Port)

2.5.1 Specification Reference

EN 301 489-1 V2.2.3: 2019, Clause 9.4

2.5.2 Equipment Under Test

SRSC-M01

2.5.3 Date of Test

26/10/2020

2.5.4 Test Method

The equipment under test including associated cabling was configured on but insulated from, using a 0.1 m isolator, a horizontal coupling plane fitted to the top of a 0.8 m non-conductive table for table-top equipment; and on a 0.1 m insulated support for floor standing equipment; above a ground reference plane all within a test laboratory.

Using a CDN for power ports, capacitive coupling clamp for signal and control ports and a 33nF coupling capacitor for earth ports, the required fast transient burst voltage levels in both voltage polarities were applied at the detailed pulse repartition rate and duration of test.

During this testing any anomalies in the equipment under tests performance was recorded.

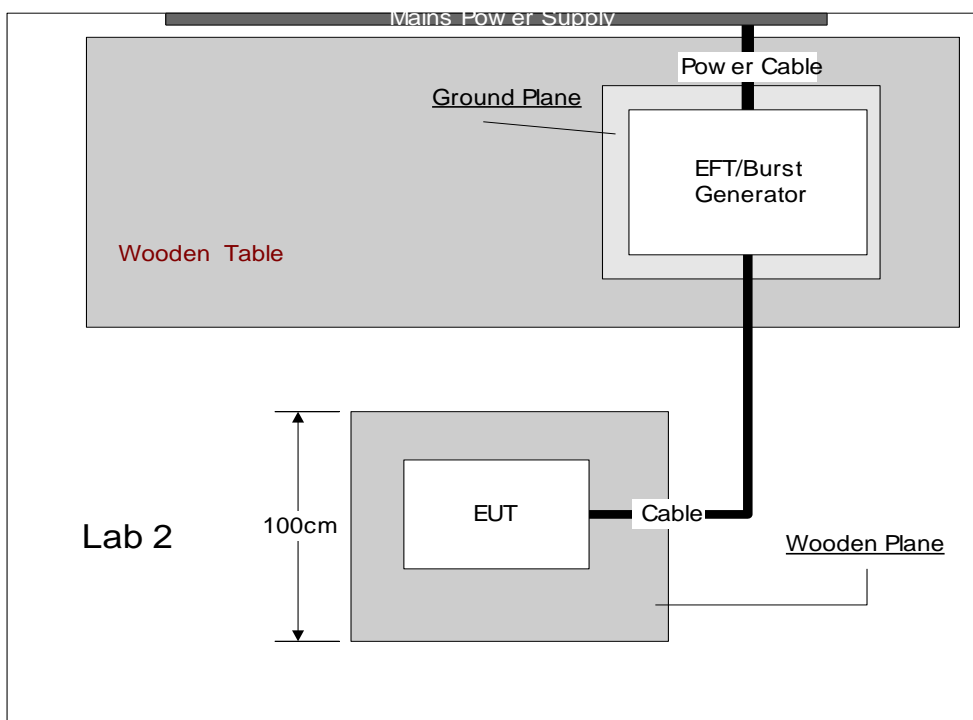



2.5.5 Environmental Conditions

Ambient Temperature 22.0 °C
 Relative Humidity 55.0 %
 Atmospheric Pressure 1012.0 mbar

2.5.6 Specification Limits

Required Test Levels					Performance Criteria
Line Under Test	Level (±kV)	Repetition Rate (kHz)	Test Duration	Coupling Method	
AC Power Port	0.5, & 1.0	5	2 min per polarity	Direct	B
Supplementary information: Note 1. EUT powered at one of the Nominal input voltages and frequencies					

2.5.7 Test Results

Results for Configuration and Mode: Configuration1 and mode1

Performance assessment of the EUT made during this test: Pass.

Detailed results are shown below.

Tabulated Results for Fast Transient Burst Immunity					
Line under test	Test Level (KV)	Repetition Rate	Test Duration	Coupling Method	Result
AC input Power lines	± 0.5 & 1.0 kV	5 kHz	2 min	CDN	Pass PC A

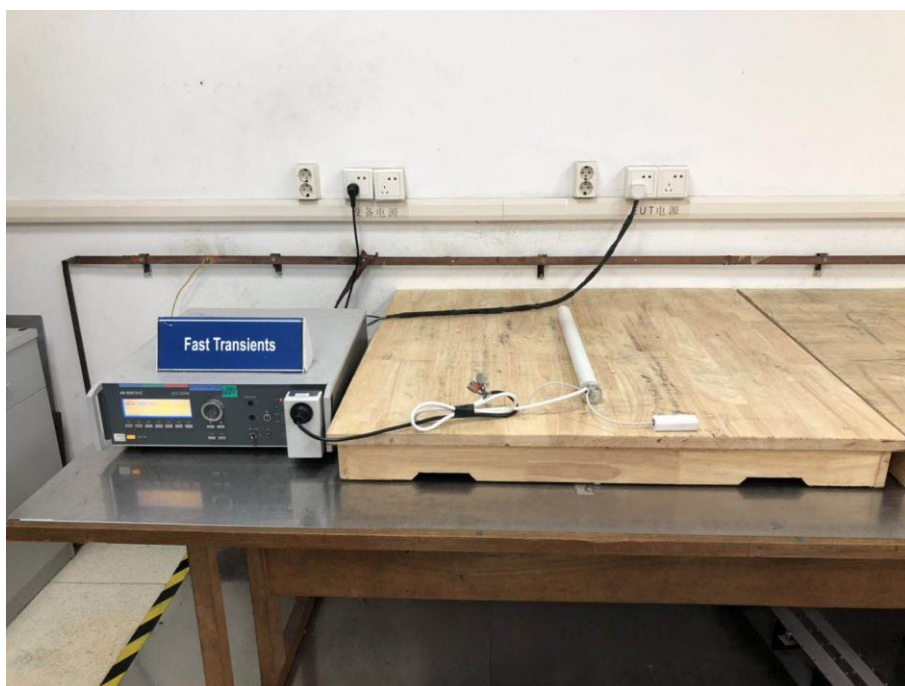

Test Setup

2.5.8 Test Location

This test was carried out in shielded room G.

2.6 Immunity to Radio Frequency (AC Power Port)

2.6.1 Specification Reference

EN 301 489-1 V2.2.3: 2019, Clause 9.5

2.6.2 Equipment Under Test

SRSC-M01

2.6.3 Date of Test

26/10/2020

2.6.4 Test Method

The equipment under test was configured, on but insulated from, using a 0.1 m isolator, a horizontal coupling plane fitted to the top of a 0.8 m non-conductive table for table-top equipment; and on a 0.1 m insulated support for floor standing equipment; above a ground reference plane all within a test laboratory.

All associated cabling was configured, on but insulated from, using a 50 mm isolator, the same horizontal coupling plane as the equipment under test.

Using CDNs, EM Clamps or current clamps as appropriate, the power ports and applicable signal and control ports were subjected to the required, pre calibrated RF injected signal strength, modulated as described, swept over the frequency range of test.

During this testing any anomalies in the equipment under tests performance was recorded.

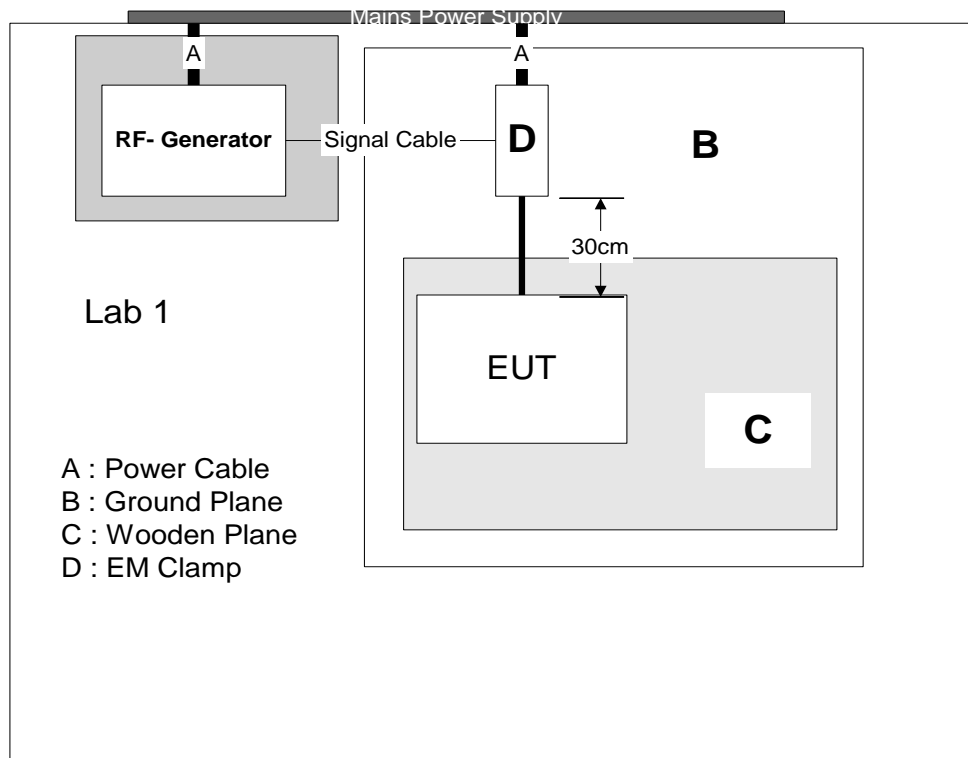



2.6.5 Environmental Conditions

Ambient Temperature 22.0 °C
 Relative Humidity 55.0 %
 Atmospheric Pressure 1012.0 mbar

2.6.6 Specification Limits

Required Test Levels						Performance Criteria
Line Under Test	Frequency Range (MHz)	Level (V)	Modulation	Step Size (%)	Dwell (s)	
AC Power Port	0.15 to 80	3	AM (80 %,1 kHz, sine wave)	1	3	A
Supplementary information:						
Note 1. EUT powered at one of the Nominal input voltages and frequencies						
Note 2. If the wanted signal is modulated at 1000 Hz, then the test signal of 400 Hz shall be used						

2.6.7 Test Results

Results for Configuration and Mode: Configuration1 and mode1

Performance assessment of the EUT made during this test: Pass.

Detailed results are shown below.

Tabulated Results for Injected current						
Line under test	Test Level	Step	Dwell Time	Coupling Method	Modulation	Result
Power Line	3V	1%	3s	CDN	1KHZ 80%	Pass PC A



Test Setup

2.6.8 Test Location

This test was carried out in shielded room G.

2.7 Immunity to Voltage dips and interruptions (AC Power Port)

2.7.1 Specification Reference

EN 301 489-1 V2.2.3 :2019, Clause 9.7

2.7.2 Equipment Under Test

SRSC-M01

2.7.3 Date of Test

26/10/2020

2.7.4 Test Method

The equipment under test including associated cabling was configured, on a 0.8 m non-conductive table for table-top equipment and on a 0.1 m insulated support for floor standing equipment above a ground reference plane all within a test laboratory.

Using a programmable power supply the equipment under test was subjected to the detailed supply voltage dips and interruptions. The required supply phase synchronization and test repetition rate, detailed, was controlled by the programmable power supply. During this testing any anomalies in the equipment under tests performance was recorded.

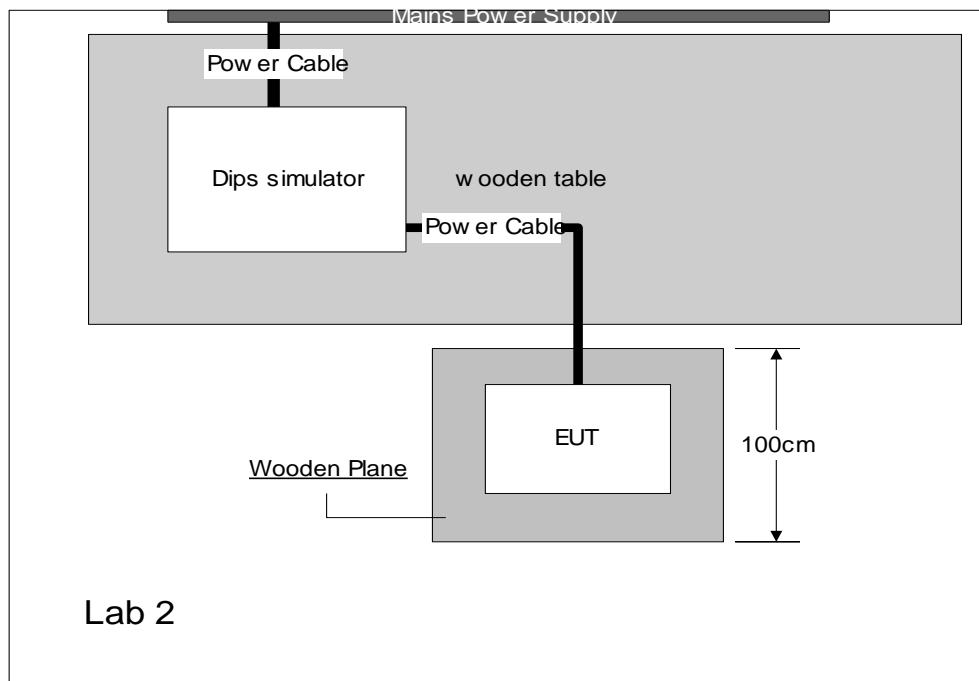



2.7.5 Environmental Conditions

Ambient Temperature 22.0 °C
 Relative Humidity 55.0 %
 Atmospheric Pressure 1008.0 mbar

2.7.6 Specification Limits

Required Test Levels			Performance Criteria
Test	Test Level % of nominal Voltage	Duration (ms) (cycles)	
Voltage Dip	0	½ cycle (50 Hz)	B
Voltage Dip	0	1 cycle	B
Voltage Dip	70	25 cycles (50 Hz)	B
Short Interruption	0	250 cycles (50 Hz)	C
Supplementary information: Note 1. EUT powered at one of the Nominal input voltages and frequencies			

2.7.7 Test Results

Results for Configuration and Mode: Configuration1 and mode1

Performance assessment of the EUT made during this test: Pass.

Detailed results are shown below.

Tabulated Results for Voltage Dip and Short Interruption					
Line under test	Vnom	Operating Frequency	Test Level	Duration	Result
Power line	230 Vac	50 Hz	0% of Vnom	½ cycle	Pass PC B
Power line	230 Vac	50 Hz	0% of Vnom	1 cycles (50Hz)	Pass PC B
Power line	230 Vac	50 Hz	70% of Vnom	25 cycles (50Hz)	Pass PC B
Power line	230 Vac	50 Hz	0% of Vnom	250 cycles (50 Hz)	Pass PC C

Remark: During the tests of voltage dips 40%,70% of Vnom and Short Interruption, the speed of motor slows down and stop working, it can get right after removing the interference.



Test Setup

2.7.8 Test Location

This test was carried out in shielded room G.

2.8 Immunity to Surges (AC Power Port)

2.8.1 Specification Reference

EN 301 489-1 V2.2.3: 2019, Clause 9.8

2.8.2 Equipment Under Test

SRSC-M01

2.8.3 Date of Test

26/10/2020

2.8.4 Test Method

The equipment under test including associated cabling was configured, on a 0.8 m non-conductive table for table-top equipment and on a 0.1 m insulated support for floor standing equipment above a ground reference plane all within a test laboratory.

Using CDNs for power ports and appropriate coupling methods for applicable signal and control ports, the required number of surges was applied for each surge voltage level using both positive and negative surge voltage polarities. Surges were applied at the power line frequency phase angles and repartition rates detailed.

During this testing any anomalies in the equipment under tests performance was recorded.

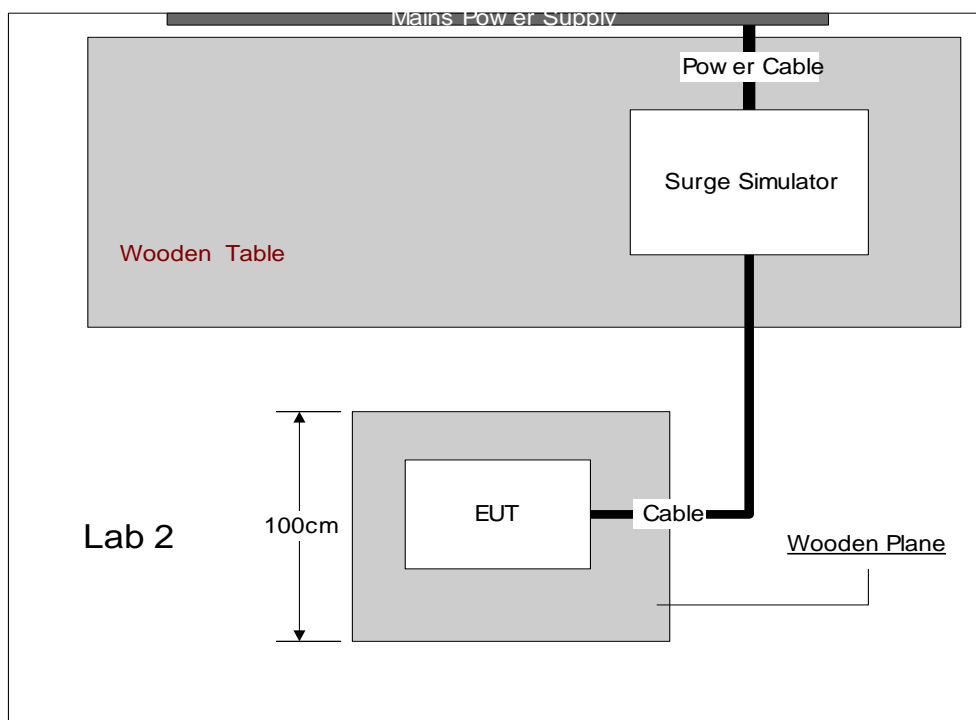



2.8.5 Environmental Conditions

Ambient Temperature 22.0 °C
 Relative Humidity 55.0 %
 Atmospheric Pressure 1012.0 mbar

2.8.6 Specification Limits

Characteristics	Test Levels	Performance Criteria
Wave- shape data Test levels line to line with 2Ω impedance line to earth with 12Ω impedance	1.2/50 μs ± 1.0 kV ±2.0 kV	B
Note In addition to the specified test level, all lower levels as detailed in IEC 61000-4-5 should also be satisfied.		

2.8.7 Test Results

Results for Configuration and Mode: Configuration1 and mode1

Performance assessment of the EUT made during this test: Pass.

Detailed results are shown below.

Tabulated Results for Surge Immunity (Power Ports)							
Line Name	Coupling	Level	Polarity	Phase Angle	No of Pulses	Repetition Rate	Result
L-N	Live to Neutral	+1.0kV	POSITIVE	0,90,180,270	5	60 sec	Pass PC A
L-N	Live to Neutral	+1.0kV	NEGATIVE	0,90,180,270	5	60 sec	Pass PC A
L-PE	Live to PE	+2.0kV	POSITIVE	0,90,180,270	5	60 sec	Pass PC A
L-PE	Live to PE	+2.0kV	NEGATIVE	0,90,180,270	5	60 sec	Pass PC A
N-PE	Neutral to PE	+2.0kV	POSITIVE	0,90,180,270	5	60 sec	Pass PC A
N-PE	Neutral to PE	+2.0kV	NEGATIVE	0,90,180,270	5	60 sec	Pass PC A



Test Setup

2.8.8 Test Location

This test was carried out in shielded room G.

2.9 Harmonic current emission

2.9.1 Specification Reference

EN 61000-3-2:2014, Clause 7

2.9.2 Equipment Under Test

SRSC-M01

2.9.3 Date of Test

26/10/2020

2.9.4 Test Method

Harmonic current test should be conducted with the user's operation control or automatic programs set to the mode expected to produce the maximum total harmonic current under normal operating conditions.

Specific test conditions for the measurement of harmonic currents associated with some types of equipment are given in Annex C.

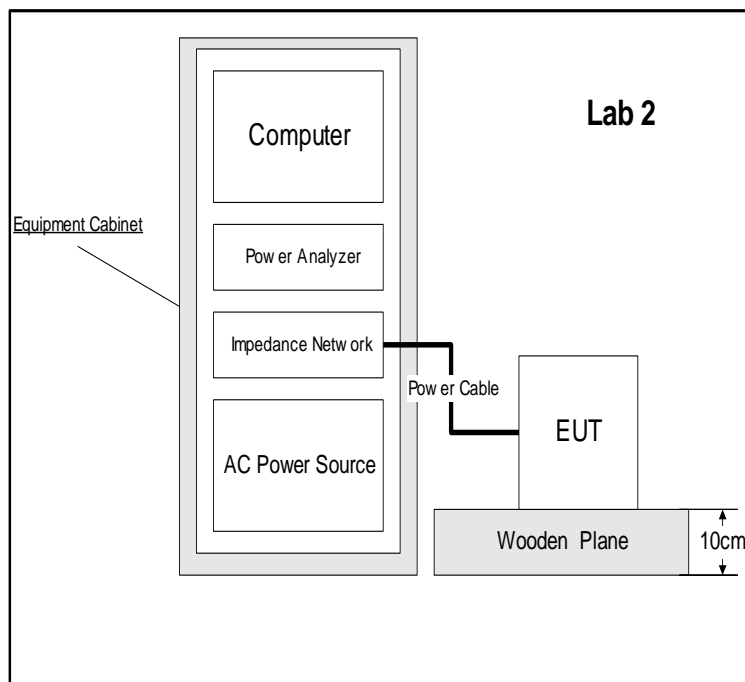

2.9.5 Environmental Conditions

Ambient Temperature 25.0 °C
 Relative Humidity 51.0 %
 Atmospheric Pressure 1012.0 mbar

2.9.6 Specification Limits

Harmonic order n	Maximum permissible harmonic current A
Odd harmonics	
3	2,30
5	1,14
7	0,77
9	0,40
11	0,33
13	0,21
$15 \leq n \leq 39$	$0,15 \frac{15}{n}$
Even harmonics	
2	1,08
4	0,43
6	0,30
$8 \leq n \leq 40$	$0,23 \frac{8}{n}$

2.9.7 Test Results

Results for Configuration and Mode: Configuration1 and mode1

Performance assessment of the EUT made during this test: *Pass*.

Detailed results are shown below:



Harmonics – Class-A per Ed. 4.0 (2014)(Run time) incl. inter-harmonics

EUT: Smart Roller Shade controller
Test category: Class-A per Ed. 4.0 (2014) (European limits) Tested by: Xin Feng
Test date: 10/26/2020 Start time: 3:41:25 PM End time: 3:44:08 PM
Test duration (min): 2.5 Data file name: CTSMXL_H-000055.cts_data
Comment: Power on, AC 230V 50Hz
Sample No:522559
Customer: Lumi United Technology Co.,Ltd

Test Result: Pass Source qualification: Normal

Current & voltage waveforms

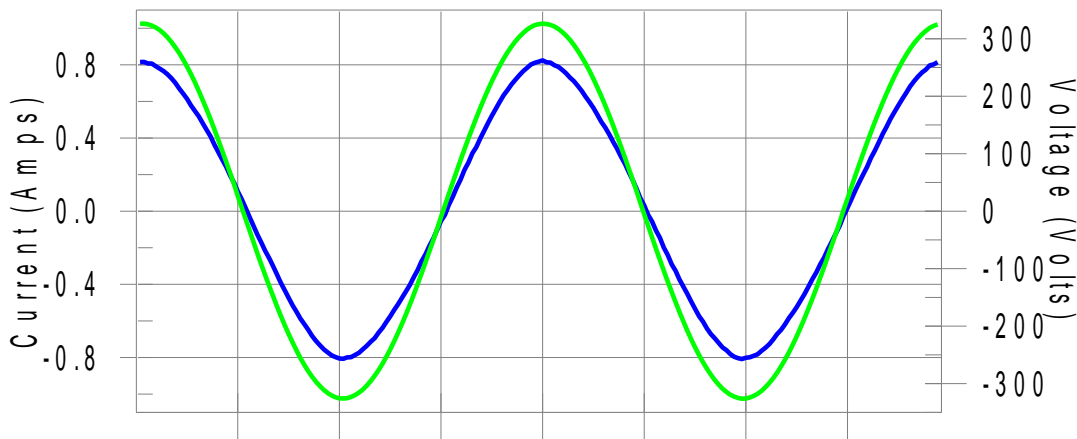

Harmonics and Class A limit line European Limits

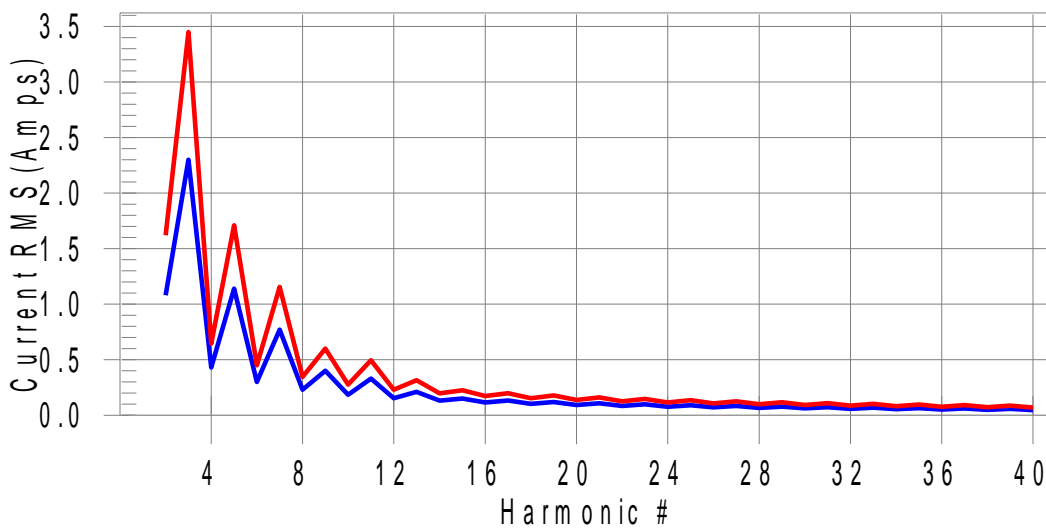

Test result: Pass Worst harmonics H3-0.4% of 150% limit, H3-0.5% of 100% limit.



Current Test Result Summary (Run time)

EUT: Smart Roller Shade controller
 Test category: Class-A per Ed. 4.0 (2014) (European limits) Tested by: Xin Feng
 Test date: 10/26/2020 Start time: 3:41:25 PM Test Margin: 100
 Test duration (min): 2.5 End time: 3:44:08 PM
 Comment: Power on, AC 230V 50Hz Data file name: CTSMXL_H-000055.cts_data
 Sample No:522559
 Customer: Lumi United Technology Co.,Ltd

Test Result: Pass Source qualification: Normal
 THC(A): 0.012 I-THD(%): 2.3 POHC(A): 0.001 POHC Limit(A): 0.251

Highest parameter values during test:

V_RMS (Volts): 230.627	Frequency(Hz): 50.00
I_Peak (Amps): 0.826	I_RMS (Amps): 0.558
I_Fund (Amps): 0.558	Crest Factor: 1.484
Power (Watts): 128.5	Power Factor: 0.999

Harm#	Harms(avg)	100%Limit	%of Limit	Harms(max)	150%Limit	%of Limit	Status
2	0.001	1.080	N/A	0.001	1.620	N/A	Pass
3	0.012	2.300	0.5	0.015	3.450	0.4	Pass
4	0.001	0.430	N/A	0.001	0.645	N/A	Pass
5	0.003	1.140	N/A	0.003	1.710	N/A	Pass
6	0.000	0.300	N/A	0.000	0.450	N/A	Pass
7	0.001	0.770	N/A	0.001	1.155	N/A	Pass
8	0.000	0.230	N/A	0.000	0.345	N/A	Pass
9	0.001	0.400	N/A	0.001	0.600	N/A	Pass
10	0.001	0.184	N/A	0.001	0.276	N/A	Pass
11	0.001	0.330	N/A	0.001	0.495	N/A	Pass
12	0.001	0.153	N/A	0.001	0.230	N/A	Pass
13	0.001	0.210	N/A	0.001	0.315	N/A	Pass
14	0.000	0.131	N/A	0.000	0.197	N/A	Pass
15	0.000	0.150	N/A	0.000	0.225	N/A	Pass
16	0.000	0.115	N/A	0.000	0.173	N/A	Pass
17	0.000	0.132	N/A	0.000	0.198	N/A	Pass
18	0.000	0.102	N/A	0.000	0.153	N/A	Pass
19	0.000	0.118	N/A	0.000	0.178	N/A	Pass
20	0.000	0.092	N/A	0.000	0.138	N/A	Pass
21	0.000	0.107	N/A	0.000	0.161	N/A	Pass
22	0.000	0.084	N/A	0.000	0.125	N/A	Pass
23	0.000	0.098	N/A	0.000	0.147	N/A	Pass
24	0.000	0.077	N/A	0.000	0.115	N/A	Pass
25	0.000	0.090	N/A	0.000	0.135	N/A	Pass
26	0.000	0.071	N/A	0.000	0.107	N/A	Pass
27	0.000	0.083	N/A	0.000	0.125	N/A	Pass
28	0.000	0.066	N/A	0.000	0.099	N/A	Pass
29	0.000	0.078	N/A	0.000	0.116	N/A	Pass
30	0.000	0.061	N/A	0.000	0.092	N/A	Pass
31	0.000	0.073	N/A	0.000	0.109	N/A	Pass
32	0.000	0.058	N/A	0.000	0.086	N/A	Pass
33	0.000	0.068	N/A	0.000	0.102	N/A	Pass
34	0.000	0.054	N/A	0.000	0.081	N/A	Pass
35	0.000	0.064	N/A	0.000	0.096	N/A	Pass
36	0.000	0.051	N/A	0.000	0.077	N/A	Pass
37	0.000	0.061	N/A	0.000	0.091	N/A	Pass
38	0.000	0.048	N/A	0.000	0.073	N/A	Pass
39	0.000	0.058	N/A	0.000	0.087	N/A	Pass
40	0.000	0.046	N/A	0.000	0.069	N/A	Pass



Test Setup

2.9.8 Test Location

This test was carried out in Harmonic Flicker Test area.

2.10 Flicker

2.10.1 Specification Reference

EN 61000-3-3:2013, Clause 6

2.10.2 Equipment Under Test

SRSC-M01

2.10.3 Date of Test

26/10/2020

2.10.4 Test Method

switch on/off

For equipment not mentioned in annex A, controls or automatic programs should be set to produce the most unfavorable sequence of voltage change, using only those combinations of controls and programmes which are mentioned by the manufacturer in the instruction manual, or are otherwise likely to be used

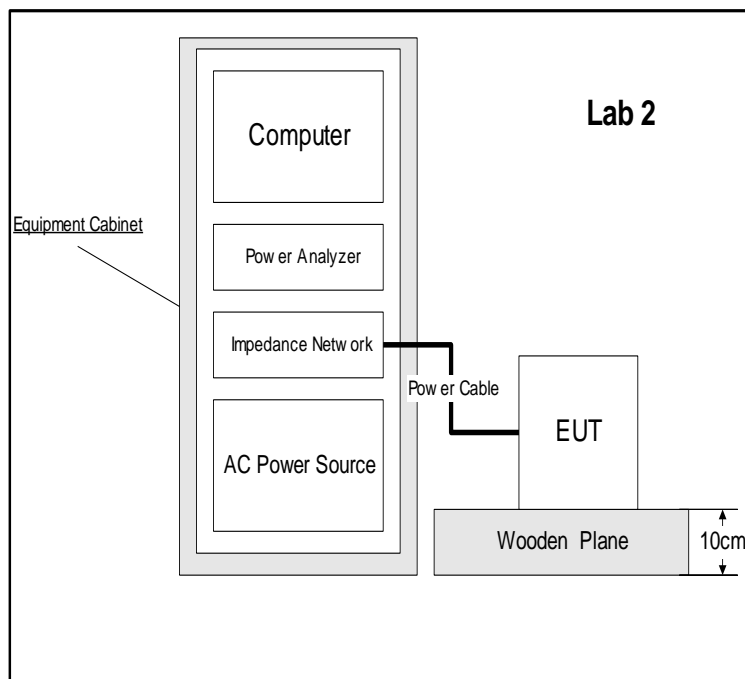



2.10.5 Environmental Conditions

Ambient Temperature 25.0 °C
 Relative Humidity 51.0 %
 Atmospheric Pressure 1012.0 mbar

2.10.6 Specification Limits

The value of Pst shall not be greater than 1.0
 The value of Plt shall not be greater than 0.65
 Tmax, the accumulated time value of d(t) with a deviation exceeding 3.3% during a single voltage change at the EUT terminals, shall not exceed 500ms
 The maximum relative steady-state voltage change, dc, shall not exceed 3.3%
 The maximum relative voltage change dmax, shall not exceed 4% without additional conditions
 6% for equipment which is:
 Switched manually, or
 Switched automatically more frequently than twice per day, and also has either a delayed start, or manual restart, after a power supply interruption
 7% for equipment which is:
 Attended whilst in use, or
 Switched on automatically, or is intended to be switched on manually, no more than twice per day, and also has either a delayed restart or manual restart, after a power supply interruption

2.10.7 Test Results

Results for Configuration and Mode: Configuration1 and mode 2

Performance assessment of the EUT made during this test: *Pass*.

Detailed results are shown below.

Parameter values recorded during the test:

Vrms at the end of test (Volt):230.62

T-max (mS):	0.0	Test limit (mS):	500.0	Pass
Highest dc (%):	0.26	Test limit (%):	3.30	Pass
Highest dmax (%):	0.28	Test limit (%):	4.00	Pass
Highest dt (%):	0.24	Test limit (%):	N/A	N/A



Test Setup

2.10.8 Test Location

This test was carried out in Harmonic Flicker Test area.

3 Test Equipment Information

3.1 General Test Equipment Used

Instrument	Manufacturer	Type No	TE No	Calibration Date	Calibration Due
Conducted Emission					
EMI Test Receiver	Rohde & Schwarz	ESHS30	707/639701	2020.5.11	2021.5.10
LISN	Schwarzbeck	NSLK8127	487/601428	2019.12.23	2020.12.22
Radiated Emissions					
EMI Test Receiver	Rohde & Schwarz	ESIB7	487/630408	2019.12.23	2020.12.22
Broadband Antenna	Schwarzbeck	VULB9168	487/621840	2020.7.26	2021.7.25
Broad-Band Horn Antenna	ETS	3115	487/621838	2019.12.6	2020.12.5
EMI Test Receiver	Rohde & Schwarz	ESU8	487/630909	2019.12.23	2020.12.22
Immunity					
ESD Simulator	HAEFELY	ONYX 30	487/751520	2020.09.17	2021.09.16
EFT/Burst Generator	EM test	UCS 500N5V	487/751218	2020.7.2	2021.7.1
Surge Generator	EM test	UCS 500N5E	487/751219	2020.7.2	2021.7.1
RF-Generator	Schaffner	NSG 2070	487/391121	2020.05.11	2021.05.10

Coupling/decoupling Network	TeseQ	CDN M016	487/571539	2020.05.11	2021.05.10
Voltage Drop Generator	EM test	UCS500N5-PFS	487/751117	2019.12.23	2020.12.22
Signal Generator	Rohde & Schwarz	SMB-100A	487/391120	2019.12.23	2020.12.22
Power Amplifier	TESEQ	CBA1G-500	487/400908	2019.12.23	2020.12.22
Power Amplifier	TESEQ	CBA3G-100	487/400909	2019.12.23	2020.12.22
Power Meter	Rohde & Schwarz	NRP-2	487/741156	2019.12.23	2020.12.22
Coupler	Amplifier Research	DC7144A	487/571117	2019.12.23	2020.12.22
Coupler	Amplifier Research	DC6180A	487/571116	2019.12.23	2020.12.22
Antenna	Schwarzbeck	STLP 9128Ds	487/621432	2019.4.25	2021.4.24
Antenna	Schwarzbeck	BBHA 9120E	487/624535	2019.4.25	2021.4.24
Power Amplifier	Amplifier Research	BBA150-E60	487/401816	2020.09.17	2021.09.16

4 Measurement Uncertainty

For a 95% confidence level, the measurement uncertainties for defined systems are:

Test Name	Measurement Uncertainty
Conducted Disturbance at Mains Terminals	150kHz to 30MHz, LISN, ± 3.09 dB
Discontinuous Disturbance	150kHz to 30MHz, LISN, ± 3.4 dB
Disturbance power	30MHz to 300MHz, ± 3.32 dB
Radiated Disturbance	30MHz to 1GHz, ± 3.88 dB
Harmonic current emission	The test was applied using proprietary equipment that meets the requirements of EN 61000-3-2.
Flicker	The test was applied using proprietary equipment that meets the requirements of EN 61000-3-3
Electrostatic discharge immunity test	The test was applied using proprietary equipment that meets the requirements of EN 61000-4-2
Electrical fast transient /burst immunity test	The test was applied using proprietary equipment that meets the requirements of EN 61000-4-4
Immunity to conducted disturbances, induced by radio-frequency fields	The test was applied using proprietary equipment that meets the requirements of EN 61000-4-6
Radiated, radio-frequency, electromagnetic field immunity test	The test was applied using proprietary equipment that meets the requirements of EN 61000-4-3
Surge immunity test	The test was applied using proprietary equipment that meets the requirements of EN 61000-4-5
Voltage dips, short interruptions and voltage variations immunity tests	The test was applied using proprietary equipment that meets the requirements of EN 61000-4-11

5 Photographs

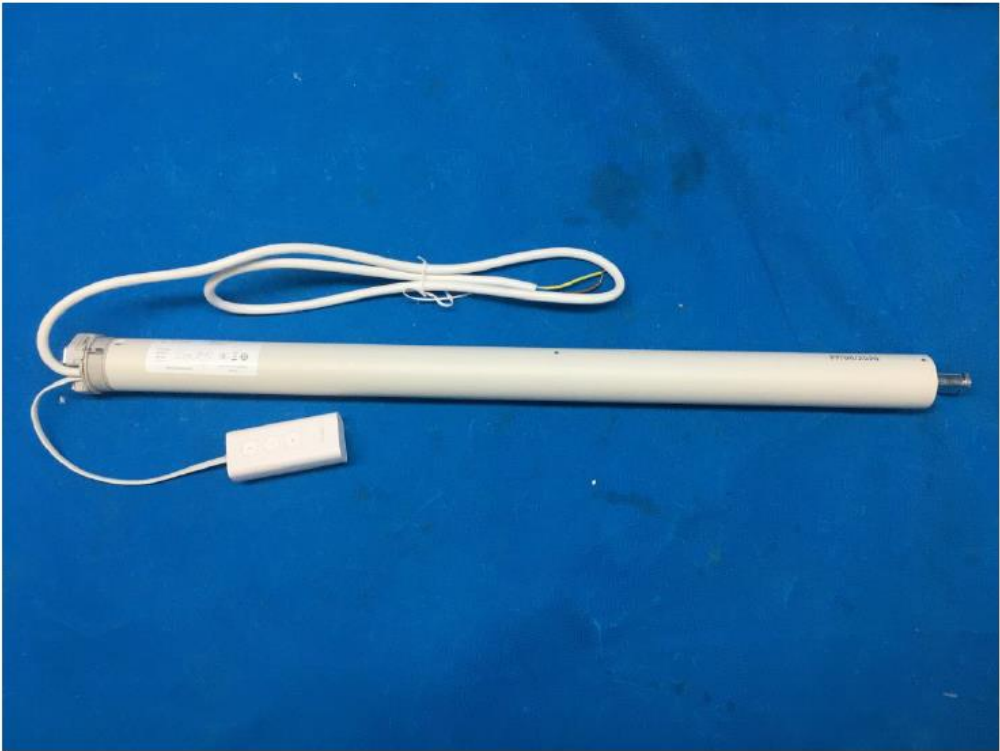

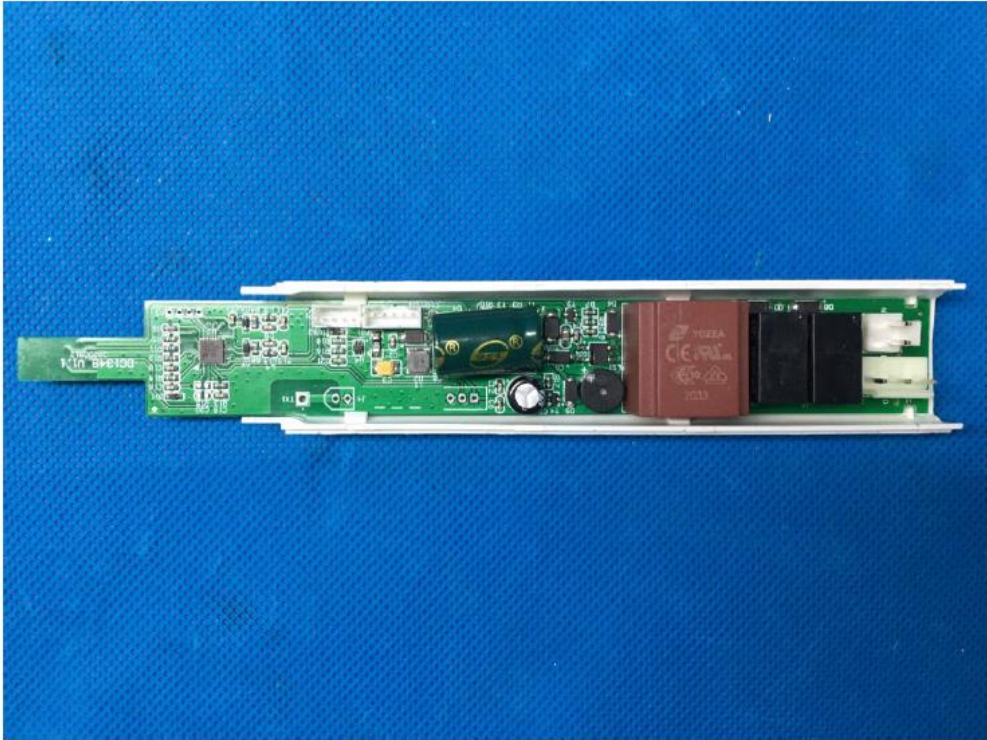
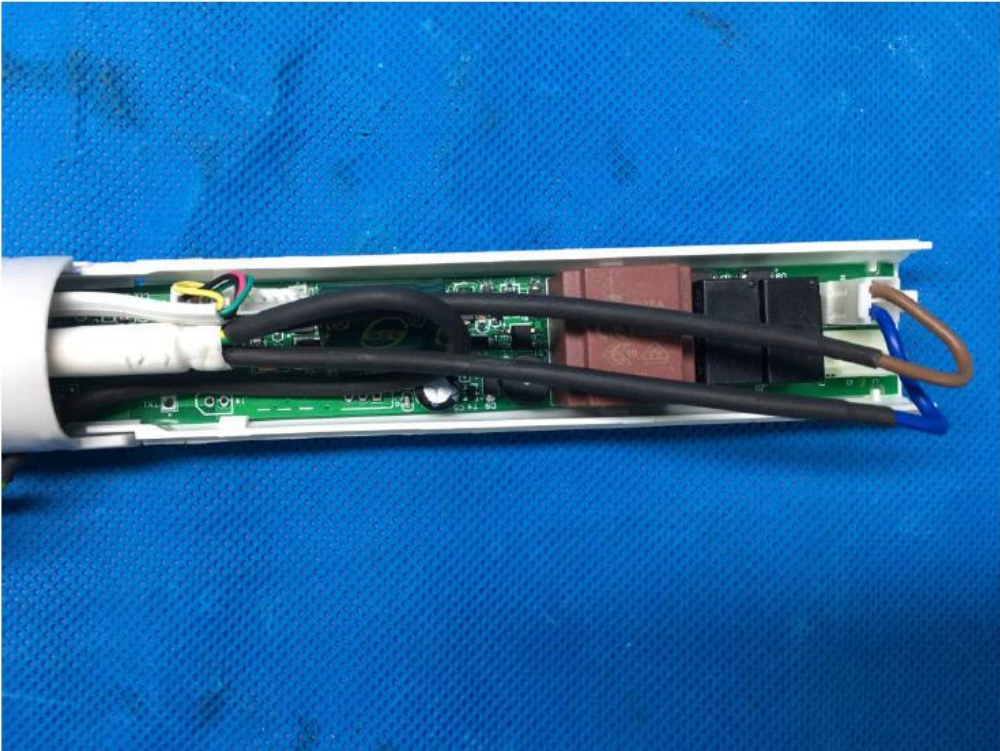



China

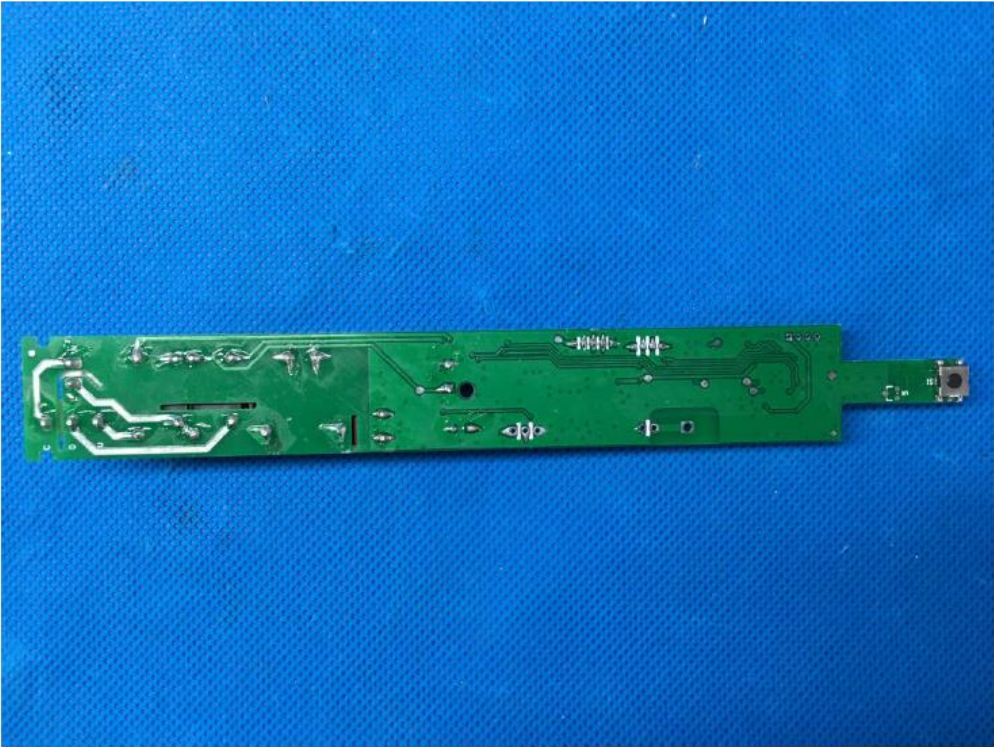
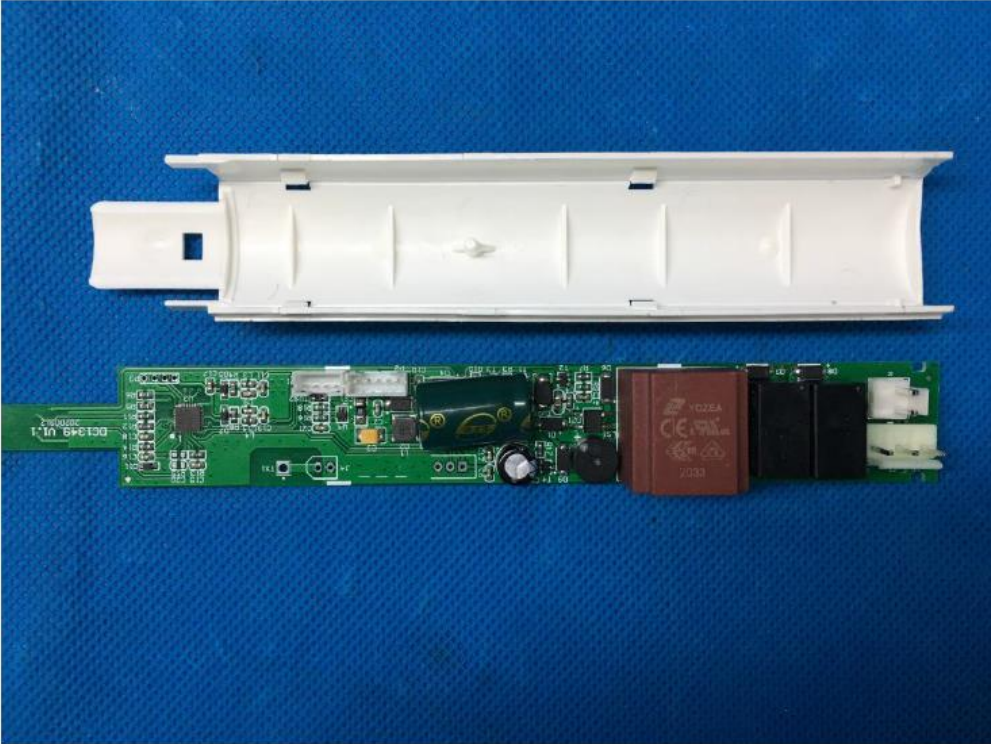



China

