



Shenzhen GTI Technology Co., Ltd.

1-2/F., Building 2, Jiaquan Building, Guanlan High-Tech Park, Shenzhen, Guangdong, China

Tel: +86-755- 27521059

Fax: +86-755- 27521011

TEST REPORT

Product Name : Wireless Mini Switch

Trademark : AQara

Model/Type reference : WXKG11LM

Test Standards : **ETSI EN 301 489-1 V2.1.1: 2017-02**
: **ETSI EN 301 489-17 V3.1.1: 2017-02**

Applicant : Lumi United Technology Co., Ltd.

Address of applicant : 8th Floor, JinQi Wisdom Valley, No.1 Tangling Road, Liuxian Ave,
Taoyuan Residential District, Nanshan District, Shenzhen, China.

Date of Receipt : Nov. 7, 2017

Date of Test Date..... : Nov. 7, 2017 to Nov.12, 2017

Date of Issue...... : Nov.16, 2017

Test result	Pass *
--------------------	---------------

* In the configuration tested, the EUT complied with the standards specified above



The CE mark as shown above can be used, under the responsibility of the manufacturer, after completion of an EC Declaration of Conformity and compliance with all relevant EC Directives. The protection requirements with respect to electromagnetic compatibility contained in Directive 2014/53/EU are considered.

GENERAL DESCRIPTION OF EUT	
Equipment:	Wireless Mini Switch
Model Name:	WXKG11LM
Adding Model(s)	/
Model difference	/
Manufacturer:	Lumi United Technology Co., Ltd.
Manufacturer Address:	8th Floor, JinQi Wisdom Valley, No.1 Tangling Road, Liuxian Ave, Taoyuan Residential District, Nanshan District, Shenzhen, China.
Power Rating:	Input: DC 3V,25mA. (This is powered by the CR2032 battery)

Compiled By:

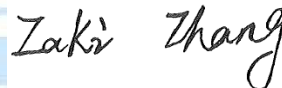

(Zaki Zhang)

Reviewed By:



(Gavin Shi)

Approved By:

Walter Chen

This test report may be duplicated completely for legal use with the approval of the applicant. It should not be reproduced except in full, without the written approval of our laboratory. The client should not use it to claim product endorsement by GTI. The test results in the report only apply to the tested sample. The test report shall be invalid without all the signatures of testing engineers, reviewer and approver. Any objections must be raised to GTI within 15 days since the date when the report is received. It will not be taken into consideration beyond this limit.

Table of Contents

Page

1. SUMMARY.....	4
1.1. TEST STANDARDS.....	4
1.2. TEST DESCRIPTION.....	4
1.3. TEST FACILITY	5
1.4. MEASUREMENT UNCERTAINTY	5
2. GENERAL INFORMATION	6
2.1. ENVIRONMENTAL CONDITIONS	6
2.2. GENERAL DESCRIPTION OF EUT	6
2.3. DESCRIPTION OF TEST MODES	7
2.4. MEASUREMENT INSTRUMENTS LIST	8
2.5. EMC EMISSION TEST	10
2.6. CONDUCTED EMISSION (AC MAINS).....	10
2.7. CONDUCTED EMISSION (TELECOMMUNICATION PORTS).....	11
2.8. RADIATED EMISSION	13
2.9. HARMONIC CURRENT EMISSIONS	17
2.10. VOLTAGE FLUCTUATIONS AND FLICKER	18
3. EMC IMMUNITY TEST	20
3.1. PERFORMANCE CRITERIA.....	20
3.2. ELECTROSTATIC DISCHARGE	22
3.3. RF ELECTROMAGNETIC FIELD.....	25
3.4. FAST TRANSIENTS COMMON MODE.....	27
3.5. SURGE TESTING.....	29
3.6. RF COMMON MODE	30
3.7. VOLTAGE DIPS AND INTERRUPTIONS	32
4. EUT TEST PHOTO	33
5. PHOTOGRAPHS OF EUT CONSTRUCTIONAL	35

1. SUMMARY

1.1. Test Standards

ETSI EN 301 489-1 V2.1.1(2017-02) – Electromagnetic compatibility and Radio spectrum Matters (ERM); Electromagnetic Compatibility (EMC) standard for radio equipment and services; Part 1: Common technical requirements

ETSI EN 301 489-17 V3.1.1 (2017-02) – Electromagnetic compatibility and Radio spectrum Matters (ERM); Electromagnetic Compatibility (EMC) standard for radio equipment; Part 17: Specific conditions for wideband transmission systems

1.2. Test Description

ETSI EN 301 489-1/ requirements		
Conducted Emission(AC Mains)	ETSI EN 301 489-1 V2.1.1Clause 7.1	N/A
Radiated Emission	ETSI EN 301 489-1 V2.1.1Clause 7.1	PASS
Conducted Emission (Telecommunication Ports)	ETSI EN 301 489-1 V2.1.1Clause 7.1	N/A
Harmonic Current Emissions	ETSI EN 301 489-1 V2.1.1Clause 7.1	N/A
Voltage Fluctuations and Flicker	ETSI EN 301 489-1 V2.1.1Clause 7.1	N/A
Electrostatic Discharge	ETSI EN 301 489-1 V2.1.1Clause 7.2	PASS
RF Electromagnetic Field	ETSI EN 301 489-1 V2.1.1Clause 7.2	PASS
Fast Transients Common Mode	ETSI EN 301 489-1 V2.1.1Clause 7.2	N/A
Surges	ETSI EN 301 489-1 V2.1.1Clause 7.2	N/A
RF Common Mode 0,15 MHz to 80 MHz	ETSI EN 301 489-1 V2.1.1Clause 7.2	N/A
Transients and Surges	ETSI EN 301 489-1 V2.1.1Clause 7.2	N/A
Voltage Dips and Interruptions	ETSI EN 301 489-1 V2.1.1Clause 7.2	N/A

Remark: (1)The measurement uncertainty is not included in the test result.
(2) "N/A" does not tested because the EUT battery powered.

1.3. Test Facility

1.3.1 Address of the test laboratory

Shenzhen General Testing & Inspection Technology Co., Ltd.

Add: 1-2/F., Building 2, Jiaquan Building, Guanlan High-Tech Park, Shenzhen, Guangdong, China

1.3.2 Laboratory accreditation

The test facility is recognized, certified, or accredited by the following organizations:

IC Registration No.: 9783A

The 3m alternate test site of Shenzhen GTI Technology Co., Ltd. EMC Laboratory has been registered by Certification and Engineer Bureau of Industry Canada for the performance of with Registration NO.: 9783A on Jan, 2016.

1.4. Measurement Uncertainty

The data and results referenced in this document are true and accurate. The reader is cautioned that there may be errors within the calibration limits of the equipment and facilities. The measurement uncertainty was calculated for all measurements listed in this test report acc. To CISPR 16 – 4 Specification for radio disturbance and immunity measuring apparatus and methods – Part 4: Uncertainty in EMC Measurements and is documented in the Shenzhen General Testing & Inspection Technology Co., Ltd quality system acc. To DIN EN ISO/IEC 17025. Furthermore, component and process variability of devices similar to that tested may result in additional deviation. The manufacturer has the sole responsibility of continued compliance of the device.

Hereafter the best measurement capability for General Testing & Inspection laboratory is reported:

A. Conducted Measurement:

Test Site	Method	Measurement Frequency Range	U , (dB)	NOTE
C01	ANSI	150 KHz ~ 30MHz	3.2	

B. Radiated Measurement:

Test	Range	Measurement Uncertainty	Notes
Radiated Emission	30~1000MHz	4.7 dB	(1)
Radiated Emission	1~18GHz	5.0 dB	(1)

(1) This uncertainty represents an expanded uncertainty expressed at approximately the 95% confidence level using a coverage factor of k=1.96.

2. GENERAL INFORMATION

2.1. Environmental conditions

During the measurement the environmental conditions were within the listed ranges:

Normal Temperature:	15°C- 35°C
Relative Humidity:	35 % - 55 %
Air Pressure:	101 kPa

2.2. General Description of EUT

Product Name:	Wireless Mini Switch
Model/Type reference:	WXKG11LM
Adding models:	/
Power supply:	Input: DC 3V,25mA. (This is powered by the CR2032 battery)
Hardware version:	V1.0.1
Software version:	V1.0.1
Zigbee	
Supported type:	ZigBee IEEE 802.15.4
Modulation:	O-QPSK
Operation frequency:	2405-2480MHz
Channel number:	16
Channel separation:	5 MHz
Antenna type:	PCB Antenna
Antenna gain:	2.0dBi

2.3. Description of Test Modes

As the function of the EUT, test mode selected to test as below to conform this standard:

Pretest Mode	Description
Mode 1	Normal working

Pre-scan above all test mode, found below test mode which it was worse case mode.

Test item	Test mode (Worse case operation mode)
Radiated emission	Mode 1
Electrostatic Discharge	Mode 1
RF Electromagnetic Field	Mode 1



2.4. Measurement Instruments List

Conducted Emission					
Item	Test Equipment	Manufacturer	Model No.	Serial No.	Calibrated until
1	LISN	R&S	ENV216	101112	Jan. 07, 2018
2	LISN	R&S	ENV216	101113	Jan. 07, 2018
3	EMI Test Receiver	R&S	ESCI	100920	Jan. 07, 2018
4	ISN CAT6	Schwarzbeck	NTFM 8158	8158-0046	Jan. 07, 2018

Radiated Emission					
Item	Test Equipment	Manufacturer	Model No.	Serial No.	Calibrated until
1	Bilog Antenna	Schwarzbeck	CBL6141A	4180	Jan. 07, 2018
2	Spectrum Analyzer	R&S	FSU26	100105	Jan. 07, 2018
3	Horn Antenna	Schwarzbeck	BBHA 9120D	647	Jan. 07, 2018
4	Low Noise Pre-Amplifier	HP	8447D	1937A03050	Jan. 07, 2018
5	Low Noise Pre-Amplifier	EMCI	EMC051835	980075	Jan. 07, 2018
6	Test Receiver	R&S	ESCI7	100967	Jan. 07, 2018
7	Antenna Mast	UC	UC3000	N/A	N/A
8	Turn Table	UC	UC3000	N/A	N/A

Harmonic Current Emissions & Voltage Fluctuations and Flicker					
Item	Test Equipment	Manufacturer	Model No.	Serial No.	Calibrated until
1	Universal Power Analyzer	Voltech	PM6000	200006700723	Jan. 07, 2018
2	Programmable AC Power Source	Mtoni	PHF1530	MTPS001	Jan. 07, 2018

Electrostatic Discharge					
Item	Test Equipment	Manufacturer	Model No.	Serial No.	Calibrated until
1	ESD Simulator	EM TEST	DITO	V1113109156	Jan. 16, 2018

RF Electromagnetic Field					
Item	Test Equipment	Manufacturer	Model No.	Serial No.	Calibrated until
1	Integrated Measurement System	R&S	IMS	100008	Jan. 07, 2018
2	Field probe	ETS	HI-6005	89587	Jan. 07, 2018
3	RS Antenna	R&S	HL046E	100037	Jan. 07, 2018
4	POWER AMPLIFIER	BONN ELEKTRONIK	BLWA 0830-160/100/40D	076788	Jan. 07, 2018

Fast Transients Common Mode					
Item	Test Equipment	Manufacturer	Model No.	Serial No.	Calibrated until
1	Electrical fast transient generator	3ctest	EFT-4003G	EC0471140	Jan. 07, 2018
2	Coupling/Decoupling Clamp	3ctest	EFTC	EC0441141	Jan. 07, 2018

Surges					
Item	Test Equipment	Manufacturer	Model No.	Serial No.	Calibrated until
1	Surge generator	3ctest	SG-5006G	EC5581149	Jan. 07, 2018
2	Surge CDN	3ctest	SGN-20G	EC5551128	Jan. 07, 2018
3	Network Surge Generator	3ctest	CWS 600T	ES0311603	Jan. 07, 2018
4	Network Surge CDN	3ctest	CDN 405T8AI	ES2731605	Jan. 07, 2018

RF Common Mode					
Item	Test Equipment	Manufacturer	Model No.	Serial No.	Calibrated until
1	Conducted Disturbances Test System	Schloder	CDG 6000	126A1266/2013	Jan. 07, 2018
2	Coupling/Decoupling	Schloder	CDN-M2+3	A2210251/2013	Jan. 07, 2018
3	Coupling and Decoupling Network	TESEQ GmbH	CDN T8-10	45011	Jan. 07, 2018

Voltage dips and interruptions					
Item	Test Equipment	Manufacturer	Model No.	Serial No.	Calibrated until
1	Voltage dips and up generator	3ctest	VDG-1105G	EC0171116	Jan. 07, 2018



2.5. EMC EMISSION TEST

2.6. Conducted Emission (AC Mains)

LIMIT

POWER LINE CONDUCTED EMISSION (Frequency Range 150KHz-30MHz)

FREQUENCY (MHz)	Class A (dBuV)		Class B (dBuV)	
	Quasi-peak	Average	Quasi-peak	Average
0.15 -0.5	79.00	66.00	66 - 56 *	56 - 46 *
0.50 -5.0	73.00	60.00	56.00	46.00
5.0 -30.0	73.00	60.00	60.00	50.00

Note:

- (1) The tighter limit applies at the band edges.
- (2) The limit of " * " marked band means the limitation decreases linearly with the logarithm of the frequency in the range.

TEST PROCEDURE

- a) The EUT was placed 0.8 meters from the horizontal ground plane with EUT being connected to the power mains through a line impedance stabilization network (LISN). All other support equipments powered from additional LISN(s). The LISN provide 50 Ohm/ 50uH of coupling impedance for the measuring instrument.
- b) Interconnecting cables that hang closer than 40 cm to the ground plane shall be folded back and forth in the center forming a bundle 30 to 40 cm long.
- c) I/O cables that are not connected to a peripheral shall be bundled in the center. The end of the cable may be terminated, if required, using the correct terminating impedance. The overall length shall not exceed 1 m.
- d) LISN at least 80 cm from nearest part of EUT chassis.
- e) For the actual test configuration, please refer to the related Item –EUT Test Photos.

TEST SETUP

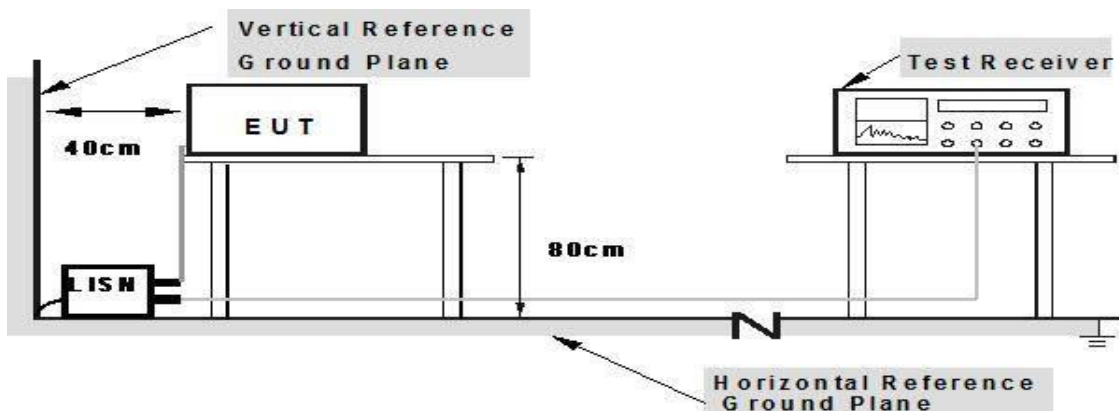

**Note: 1.Support units were connected to second LISN.
2.Both of LISNs (AMN) are 80 cm from EUT and at least 80 from other units and other metal planes**

TEST RESULTS

The test is not applicable in this Test Report.

2.7. Conducted Emission (Telecommunication Ports)

LIMIT

POWER LINE CONDUCTED EMISSION (Frequency Range 150KHz-30MHz)

FREQUENCY (MHz)	Class A (dBuV)		Class B (dBuV)	
	Quasi-peak	Average	Quasi-peak	Average
0.15 -0.5	97 to 87	84 to 74	84 to 74	74 to 64
0.5 -30.0	87	74	74	64

NOTE 1 The limits decrease linearly with the logarithm of the frequency in the range 0,15 MHz to 0,5 MHz.

NOTE 2 The current and voltage disturbance limits are derived for use with an impedance stabilization network

(ISN) which presents a common mode (asymmetric mode) impedance of 150Ω to the telecommunication port under test (conversion factor is $20 \log_{10} 150 / I = 44 \text{ dB}$).

TEST PROCEDURE

- The EUT was placed 0.8 meters from the horizontal ground plane with EUT being connected to the power mains through a line impedance stabilization network (LISN). All other support equipments powered from additional LISN(s). The LISN provide 50 Ohm/ 50uH of coupling impedance for the measuring instrument.
- Interconnecting cables that hang closer than 40 cm to the ground plane shall be folded back and forth in the center forming a bundle 30 to 40 cm long.
- I/O cables that are not connected to a peripheral shall be bundled in the center. The end of the cable may be terminated, if required, using the correct terminating impedance. The overall length shall not exceed 1 m.
- LISN at least 80 cm from nearest part of EUT chassis.
- For the actual test configuration, please refer to the related Item –EUT Test Photos.

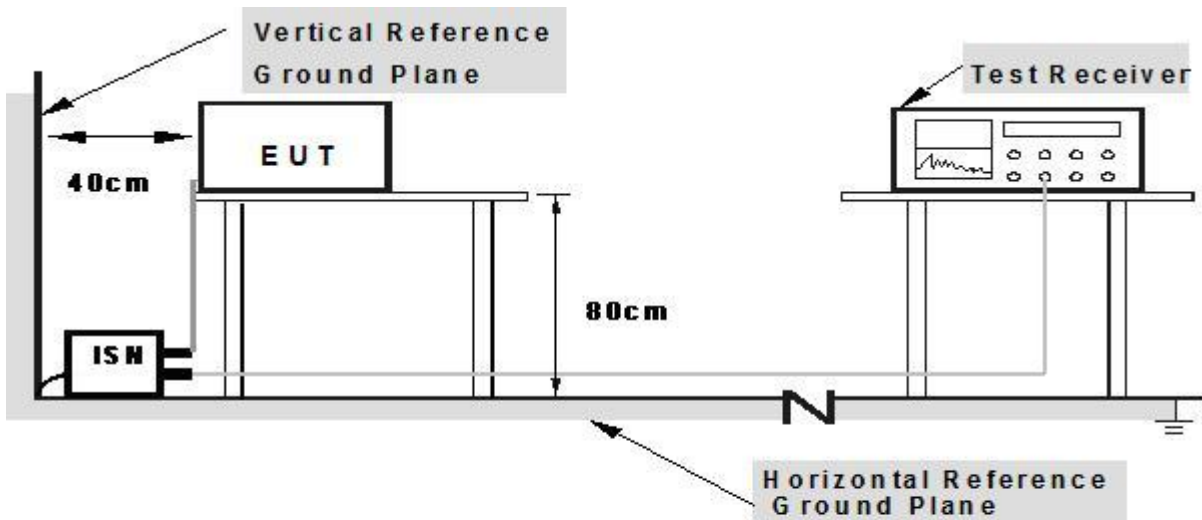

Note: 1. Support units were connected to second LISN.

2. Both of ISM (LISN) are 80 cm from EUT and at least 80 cm from other units and other metal planes

TEST RESULTS

The test is not applicable in this Test Report .



2.8. Radiated Emission

LIMITS

LIMITS OF RADIATED EMISSION MEASUREMENT (Below 1000MHz)

FREQUENCY (MHz)	Class A (at 10m)	Class B (at 10m)
	dBuV/m	dBuV/m
30 – 230	40	30
230 – 1000	47	37

LIMITS OF RADIATED EMISSION MEASUREMENT(Above 1000MHz)

FREQUENCY (MHz)	Class A (at 10m) dBuV/m		Class B (at 10m) dBuV/m	
	Peak	Avg	Peak	Avg
1000-3000	76	56	70	50
3000-6000	80	60	74	54

Notes:

- 1) The limit for radiated test was performed according to as following:
CISPR 22/ FCC PART 15B /ICES-003.
- 2) The tighter limit applies at the band edges.
- 3) Emission level (dBuV/m)=20log Emission level (uV/m).

TEST PROCEDURE

- a) The measuring distance of at 10 m shall be used for measurements at frequency up to 1GHz. For frequencies above 1GHz, any suitable measuring distance may be used.
- b) The EUT was placed on the top of a rotating table 0.8 meters above the ground at a 10 meter open area test site. The table was rotated 360 degrees to determine the position of the highest radiation.
- c) The height of the equipment or of the substitution antenna shall be 0.8 m; the height of the test antenna shall vary between 1 m to 4 m. Both horizontal and vertical polarizations of the antenna are set to make the measurement.
- d) The initial step in collecting conducted emission data is a spectrum analyzer peak detector mode pre-scanning the measurement frequency range. Significant peaks are then marked and then Quasi Peak detector mode re-measured.
- e) If the Peak Mode measured value compliance with and lower than Quasi Peak Mode Limit, the EUT shall be deemed to meet QP Limits and then no additional QP Mode measurement performed.
- f) For the actual test configuration, please refer to the related Item –EUT Test Photos.

TEST SETUP

(A) Radiated Emission Test Set-Up Frequency Below 1 GHz

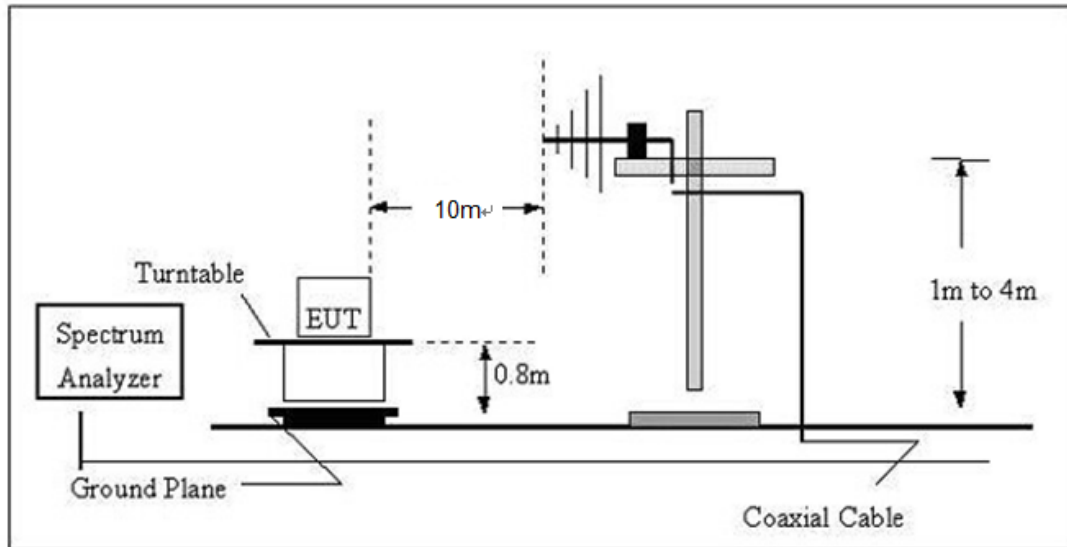

(B) Radiated Emission Test Set-Up Frequency above 1GHz

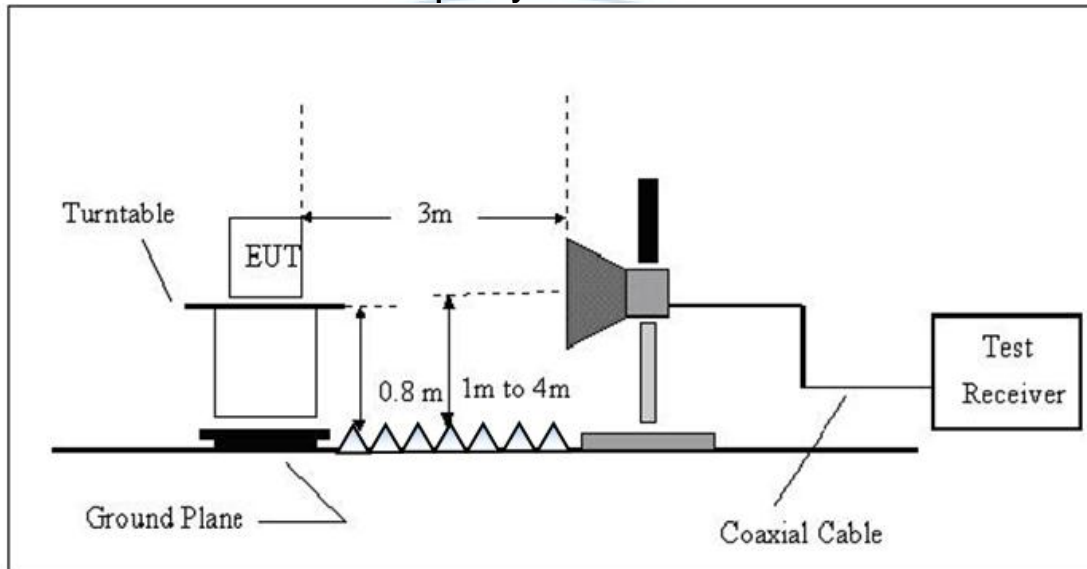

TEST RESULTS

Test mode:	Mode 1	Polarization:	Horizontal
-------------------	--------	----------------------	------------

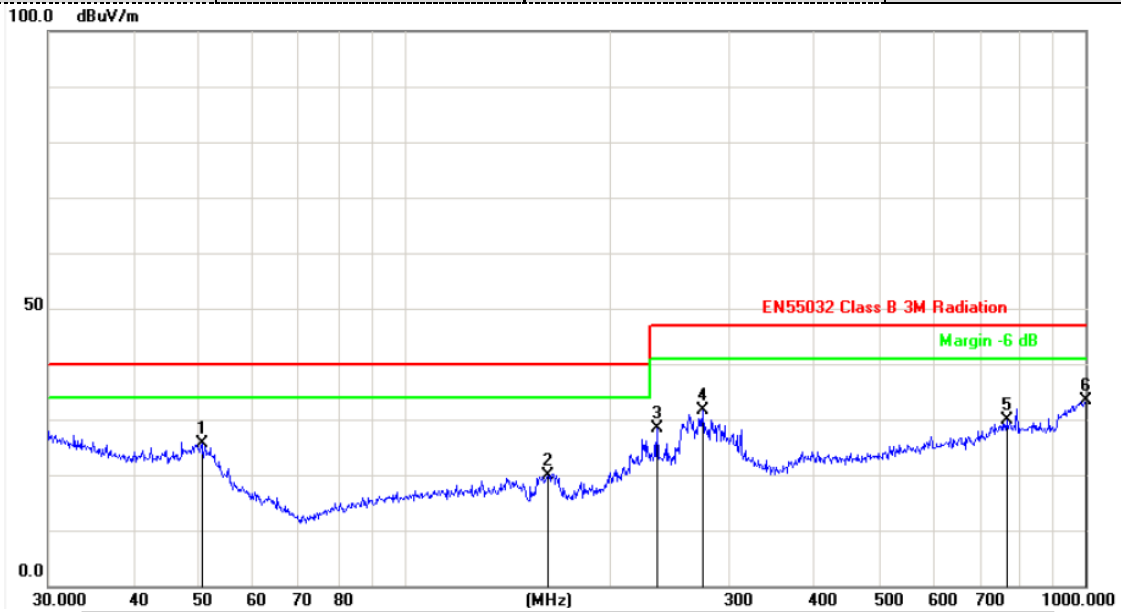

No.	Frequency (MHz)	Factor (dB/m)	Reading (dBuV)	Level (dBuV/m)	Limit (dBuV/m)	Margin (dB)	Detector	Height (cm)	Azimuth ()	P/F	Remark
1	50.4089	-11.81	37.34	25.53	40.00	-14.47	QP			P	
2	162.6105	-16.78	36.60	19.82	40.00	-20.18	QP			P	
3	234.9909	-13.61	42.04	28.43	47.00	-18.57	QP			P	
4	274.1938	-11.80	43.35	31.55	47.00	-15.45	QP			P	
5	766.0570	-3.71	33.50	29.79	47.00	-17.21	QP			P	
6	1000.0000	0.70	32.68	33.38	47.00	-13.62	QP			P	

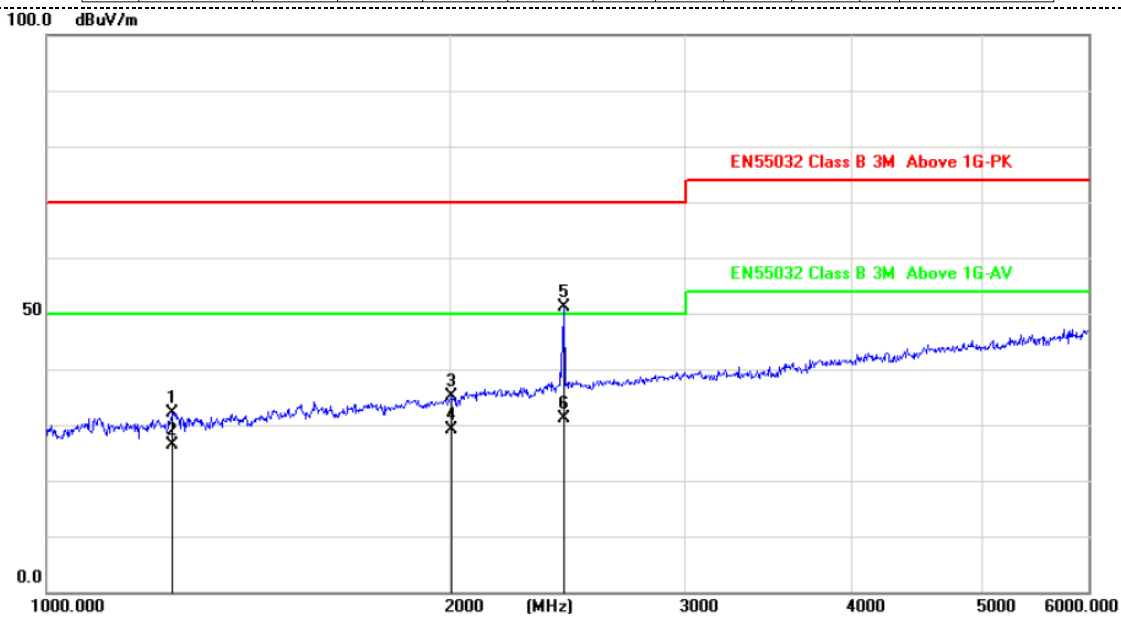

No.	Frequency (MHz)	Factor (dB/m)	Reading (dBuV)	Level (dBuV/m)	Limit (dBuV/m)	Margin (dB)	Detector	Height (cm)	Azimuth ()	P/F	Remark
1	1239.876	-20.80	52.84	32.04	70.00	-37.96	peak			P	
2	1239.876	-20.80	47.10	26.30	50.00	-23.70	AVG			P	
3	2007.709	-15.27	50.46	35.19	70.00	-34.81	peak			P	
4	2007.709	-15.27	44.37	29.10	50.00	-20.90	AVG			P	
5	2436.358	-12.91	63.93	51.02	70.00	-18.98	peak			P	
6	2436.358	-12.91	44.11	31.20	50.00	-18.80	AVG			P	

Shenzhen General Testing & Inspection Technology Co., Ltd.

1-2/F., Building 2, Jiaquan Building, Guanlan High-Tech Park, Shenzhen, Guangdong, China
 Tel.: (86)755-27521059 Fax: (86)755-27521011 Http://www.sz-ctc.org.cn



For anti-fake verification, please visit the official website of Certification and Accreditation Administration of the People's Republic of China : yz.cncaic.cn

Test mode:	Mode 1	Polarization:	Vertical
-------------------	--------	----------------------	----------

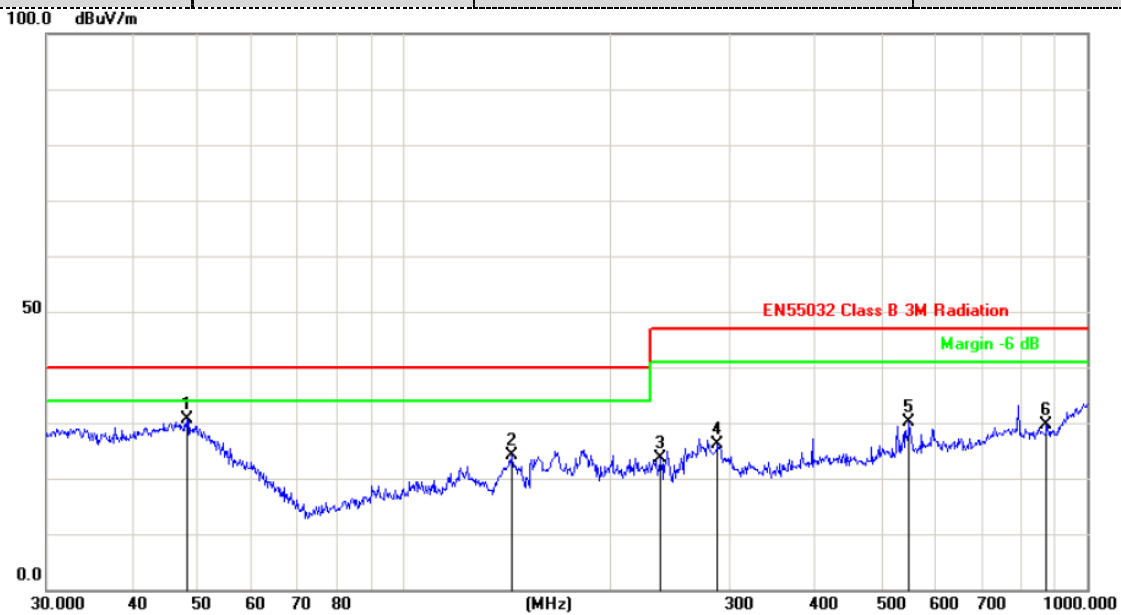

No.	Frequency (MHz)	Factor (dB/m)	Reading (dBuV)	Level (dBuV/m)	Limit (dBuV/m)	Margin (dB)	Detector	Height (cm)	Azimuth ()	P/F	Remark
1	48.1625	-11.06	41.59	30.53	40.00	-9.47	QP			P	
2	143.8294	-15.49	39.52	24.03	40.00	-15.97	QP			P	
3	237.4758	-13.80	37.50	23.70	47.00	-23.30	QP			P	
4	287.9904	-11.72	37.91	26.19	47.00	-20.81	QP			P	
5	549.0193	-7.82	37.92	30.10	47.00	-16.90	QP			P	
6	872.1832	-3.91	33.47	29.56	47.00	-17.44	QP			P	

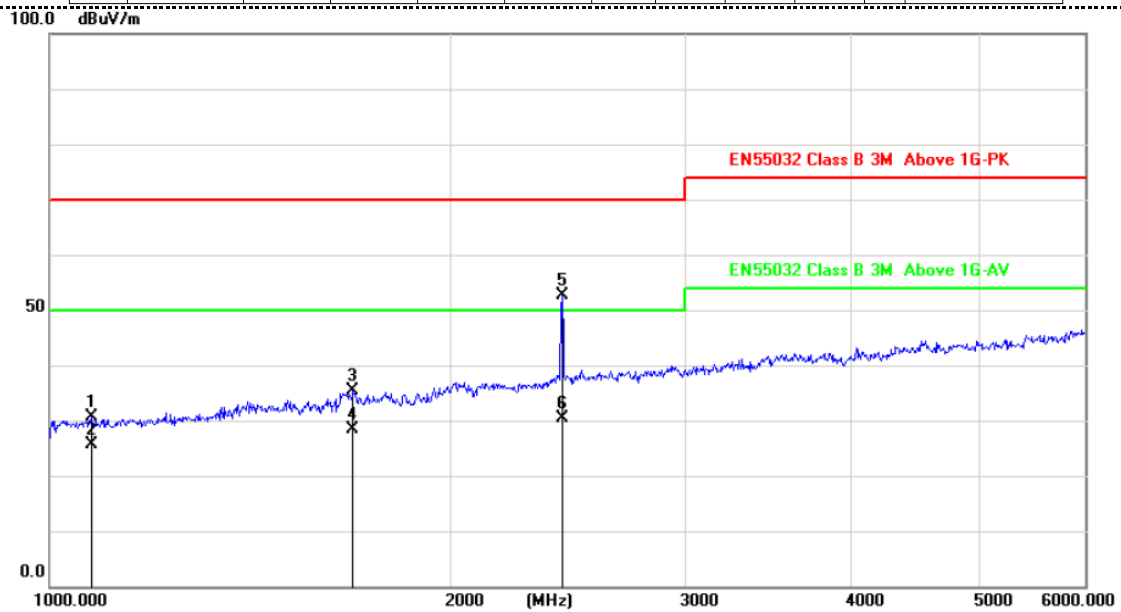

No.	Frequency (MHz)	Factor (dB/m)	Reading (dBuV)	Level (dBuV/m)	Limit (dBuV/m)	Margin (dB)	Detector	Height (cm)	Azimuth ()	P/F	Remark
1	1074.301	-22.70	53.33	30.63	70.00	-39.37	peak			P	
2	1074.301	-22.70	48.30	25.60	50.00	-24.40	AVG			P	
3	1690.434	-18.95	54.33	35.38	70.00	-34.62	peak			P	
4	1690.434	-18.95	47.25	28.30	50.00	-21.70	AVG			P	
5	2427.643	-12.94	65.58	52.64	70.00	-17.36	peak			P	
6	2427.643	-12.94	43.34	30.40	50.00	-19.60	AVG			P	

Shenzhen General Testing & Inspection Technology Co., Ltd.

1-2/F., Building 2, Jiaquan Building, Guanlan High-Tech Park, Shenzhen, Guangdong, China
 Tel.: (86)755-27521059 Fax: (86)755-27521011 Http://www.sz-ctc.org.cn

2.9. Harmonic Current Emissions

LIMITS

EN 61000-3-2/IEC 61000-3-2					
Equipment Category	Max. Permissible Harmonic Current (in Amperes)	Equipment Category	Harmonic Order n	Max. Permissible Harmonic Current (in A) (mA/w)	
Class A	Same as Limits Specified in 4-2.1, Table - I, but only odd harmonics required	Class D	3	2.30	3.4
			5	1.14	1.9
			7	0.77	1.0
			9	0.40	0.5
			11	0.33	0.35
			13 ≤ n ≤ 39	see Table I	3.85/n
only odd harmonics required					

TEST PROCEDURE

- The EUT was placed on the top of a wooden table 0.8 meters above the ground and operated to produce the maximum harmonic components under normal operating conditions.
- The classification of EUT is according to section 5 of EN 61000-3-2: 2000. The EUT is classified as follows:
 Class A: Balanced three-phase equipment, Household appliances excluding equipment as Class D, Tools excluding portable tools, Dimmers for incandescent lamps, audio equipment, equipment not specified in one of the three other classes.
 Class B: Portable tools. Portable tools.; Arc welding equipment which is not professional equipment.
 Class C: Lighting equipment.
 Class D: Equipment having a specified power less than or equal to 600 W of the following types: Personal computers and personal computer monitors and television receivers.
- The correspondent test program of test instrument to measure the current harmonics emanated from EUT is chosen. The measure time shall be not less than the time necessary for the EUT to be exercised.
- For the actual test configuration, please refer to the related item –EUT Test Photos.

TEST SETUP

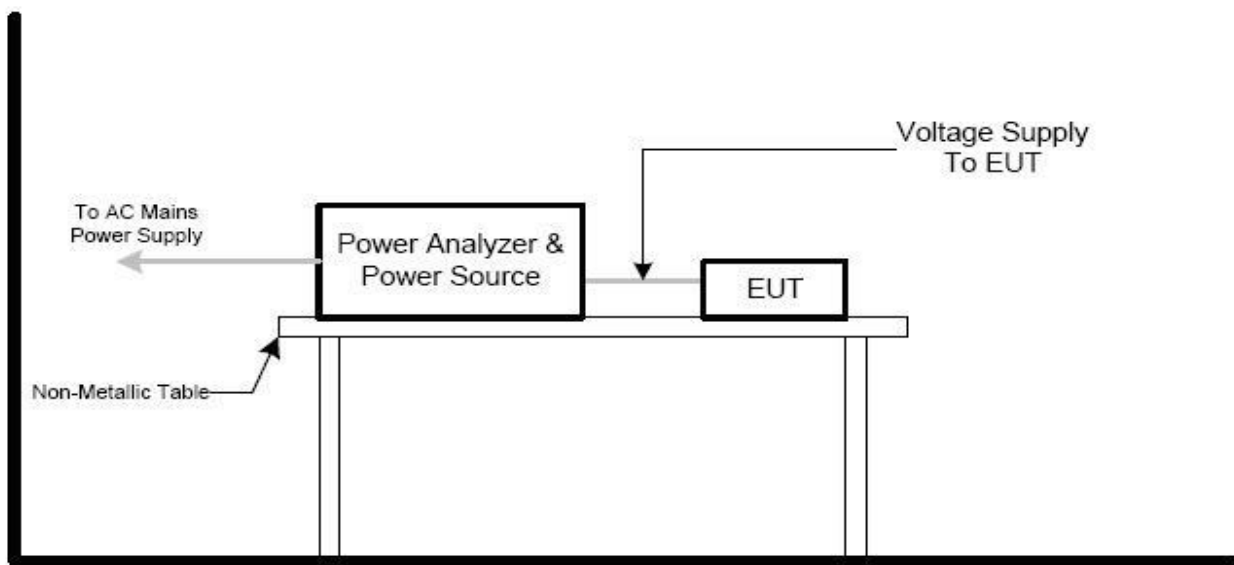

TEST RESULTS

The test is not applicable in this Test Report .

2.10. Voltage Fluctuations and Flicker

LIMITS

Tests	Limits		Descriptions
	IEC555-3	IEC/EN 61000-3-3	
Pst	≤ 1.0, Tp= 10 min.	≤ 1.0, Tp= 10 min.	Short Term Flicker Indicator
Plt	N/A	≤ 0.65, Tp=2 hr.	Long Term Flicker Indicator
dc	≤ 3%	≤ 3.3%	Relative Steady-State V-Chang
dmax	≤ 4%	≤ 4%	Maximum Relative V-change
d (t)	N/A	≤ 3.3% for > 500 ms	Relative V-change characteristic

TEST PROCEDURE

- a) Harmonic Current Test:
Test was performed according to the procedures specified in Clause 5.0 of IEC555-2 and/or Sub-clause 6.2 of IEC/EN 61000-3-2 depend on which standard adopted for compliance
- b) Fluctuation and Flickers Test:
Tests was performed according to the Test Conditions/Assessment of Voltage Fluctuations specified in Clause 5.0/6.0 of IEC555-3 and/or Clause 6.0/4.0 of IEC/EN 61000-3-3 depend on which standard adopted for compliance measurement.
- c) All types of harmonic current and/or voltage fluctuation in this report are assessed by direct measurement using flicker-meter.
- d) For the actual test configuration, please refer to the related Item –EUT Test Photos.

TEST SETUP

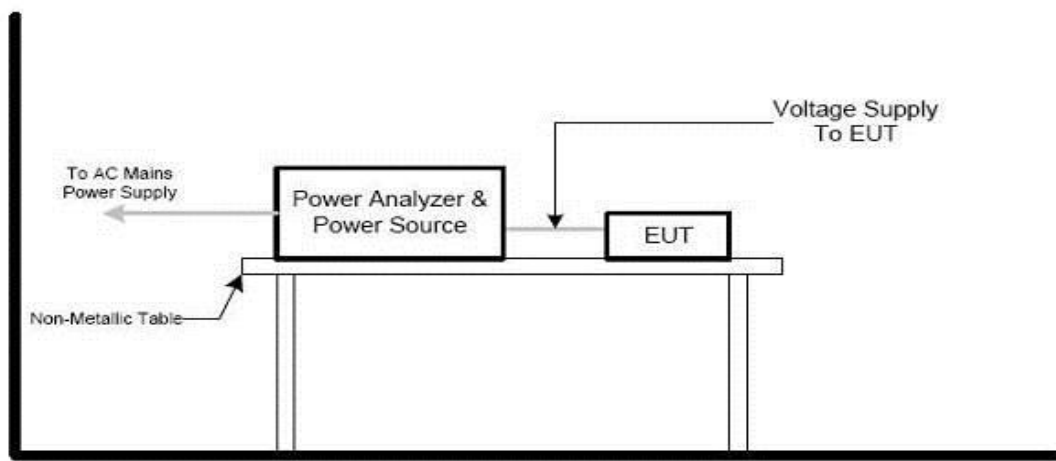

TEST RESULTS

The test is not applicable in this Test Report .



3. EMC IMMUNITY TEST

3.1. Performance criteria

A. EN301489-17

General performance criteria

- Performance criteria A for immunity tests with phenomena of a continuous nature;
- Performance criteria B for immunity tests with phenomena of a transient nature;
- Performance criteria C for immunity tests with power interruptions exceeding a certain time.

The equipment shall meet the minimum performance criteria as specified in the following.

Criteria	During test	After test
A	<p>Shall operate as intended.</p> <p>May show degradation of performance (see note 1).</p> <p>Shall be no loss of function.</p> <p>Shall be no unintentional transmissions.</p>	<p>Shall operate as intended.</p> <p>Shall be no degradation of performance (see note 2).</p> <p>Shall be no loss of function.</p> <p>Shall be no loss of stored data or user programmable functions.</p>
B	<p>May show loss of function (one or more).</p> <p>May show degradation of performance (see note 1).</p> <p>No unintentional transmissions.</p>	<p>Functions shall be self-recoverable.</p> <p>Shall operate as intended after recovering.</p> <p>Shall be no degradation of performance (see note 2).</p> <p>Shall be no loss of stored data or user programmable functions.</p>
C	<p>May be loss of function (one or more).</p>	<p>Functions shall be recoverable by the operator.</p> <p>Shall operate as intended after recovering.</p> <p>Shall be no degradation of performance (see note 2).</p>

NOTE 1:

Degradation of performance during the test is understood as a degradation to a level not below a minimum performance level specified by the manufacturer for the use of the apparatus as intended. In some cases the specified minimum performance level may be replaced by a permissible degradation of performance.

If the minimum performance level or the permissible performance degradation is not specified by the manufacturer then either of these may be derived from the product description and documentation (including leaflets and advertising) and what the user may reasonably expect from the apparatus if used as intended.

NOTE 2:

No degradation of performance after the test is understood as no degradation below a minimum performance level specified by the manufacturer for the use of the apparatus as intended. In some cases the specified minimum performance level may be replaced by a permissible degradation of performance. After the test no change of actual operating data or user retrievable data is allowed.

If the minimum performance level or the permissible performance degradation is not specified by the manufacturer then either of these may be derived from the product description and documentation (including leaflets and advertising) and what the user may reasonably expect from the apparatus if used as intended.

Performance criteria for Continuous phenomena applied to Transmitters (CT)

The performance criteria A shall apply.

Tests shall be repeated with the EUT in standby mode (if applicable) to ensure that unintentional transmission does not occur. In systems using acknowledgement signals, it is recognized that an ACKnowledgement (ACK) or Not ACKnowledgement (NACK) transmission may occur, and steps should be taken to ensure that any transmission resulting from the application of the test is correctly interpreted.

Performance criteria for Transient phenomena applied to Transmitters (TT)

The performance criteria B shall apply, except for voltage dips of 100 ms and voltage interruptions of 5 000 ms duration, for which performance criteria C shall apply.

Tests shall be repeated with the EUT in standby mode (if applicable) to ensure that unintentional transmission does not occur. In systems using acknowledgement signals, it is recognized that an acknowledgement (ACK) or not-acknowledgement (NACK) transmission may occur, and steps should be taken to ensure that any transmission resulting from the application of the test is correctly interpreted.

Performance criteria for Continuous phenomena applied to Receivers (CR)

The performance criteria A shall apply.

Where the EUT is a transceiver, under no circumstances, shall the transmitter operate unintentionally during the test. In systems using acknowledgement signals, it is recognized that an ACK or NACK transmission may occur, and steps should be taken to ensure that any transmission resulting from the application of the test is correctly interpreted.

Performance criteria for Transient phenomena applied to Receivers (TR)

The performance criteria B shall apply, except for voltage dips of 100 ms and voltage interruptions of 5 000 ms duration for which performance criteria C shall apply.

Where the EUT is a transceiver, under no circumstances, shall the transmitter operate unintentionally during the test. In systems using acknowledgement signals, it is recognized that an ACK or NACK transmission may occur, and steps should be taken to ensure that any transmission resulting from the application of the test is correctly interpreted.

3.2. Electrostatic Discharge

TEST SPECIFICATION

Basic Standard:	IEC/EN 61000-4-2
Discharge Impedance:	330 ohm / 150 pF
Required Performance	B
Discharge Voltage:	Air Discharge : 2kV/4kV/8kV (Direct) Contact Discharge : 2kV/4kV (Direct/Indirect)
Polarity:	Positive & Negative
Number of Discharge:	Air Discharge: min. 20 times at each test point Contact Discharge: min. 200 times in total
Discharge Mode:	AC Discharge
Discharge Period:	1 second minimum

TEST PROCEDURE

The test generator necessary to perform direct and indirect application of discharges to the EUT in the following manner:

- a) Contact discharge was applied to conductive surfaces and coupling planes of the EUT. During the test, it was performed with single discharges. For the single discharge time between successive single discharges was at least 1 second. The EUT shall be exposed to at least 200 discharges, 100 each at negative and positive polarity, at a minimum of four test points. One of the test points shall be subjected to at least 50 indirect discharges to the center of the front edge of the horizontal coupling plane. The remaining three test points shall each receive at least 50 direct contact discharges.

If no direct contact test points are available, then at least 200 indirect discharges shall be applied in the indirect mode. Test shall be performed at a maximum repetition rate of one discharge per second.

Vertical Coupling Plane (VCP):

The coupling plane, of dimensions 0.5m x 0.5m, is placed parallel to, and positioned at a distance 0.1m from, the EUT, with the Discharge Electrode touching the coupling plane. The four faces of the EUT will be performed with electrostatic discharge.

Horizontal Coupling Plane (HCP):

The coupling plane is placed under to the EUT. The generator shall be positioned vertically at a distance of 0.1m from the EUT, with the Discharge Electrode touching the coupling plane. The four faces of the EUT will be performed with electrostatic discharge.

- b) Air discharges at insulation surfaces of the EUT. It was at least ten single discharges with positive and negative at the same selected point.
- c) For the actual test configuration, please refer to the related Item –EUT Test Photos.

TEST SETUP

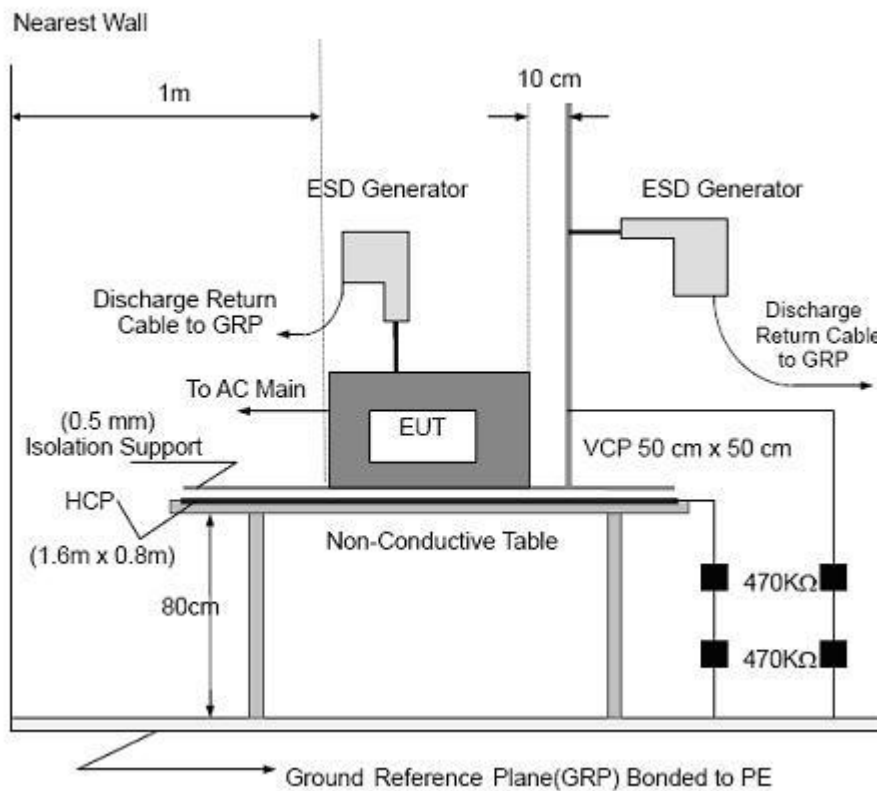

Note:

TABLE-TOP EQUIPMENT

The configuration consisted of a wooden table 0.8 meters high standing on the Ground Reference Plane. The GRP consisted of a sheet of aluminum at least 0.25mm thick, and 2.5 meters square connected to the protective grounding system. A Horizontal Coupling Plane (1.6m x 0.8m) was placed on the table and attached to the GRP by means of a cable with 940k total impedance. The equipment under test, was installed in a representative system as described in section 7 of IEC /EN 61000-4-2, and its cables were placed on the HCP and isolated by an insulating support of 0.5mm thickness. A distance of 1-meter minimum was provided between the EUT and the walls of the laboratory and any other metallic structure.

FLOOR-STANDING EQUIPMENT

The equipment under test was installed in a representative system as described in section 7 of IEC/EN 61000-4-2, and its cables were isolated from the Ground Reference Plane by an insulating support of 0.1-meter thickness. The GRP consisted of a sheet of aluminum that is at least 0.25mm thick, and 2.5meters square connected to the protective grounding system and extended at least 0.5 meters from the EUT on all sides.

TEST RESULTS

Test Mode	Mode1				
Test Points	Test Voltage	Kind	times	Phenomenon	Test Result
GAP	<input checked="" type="checkbox"/> ±2 KV ; <input checked="" type="checkbox"/> ±4KV <input type="checkbox"/> ±6 KV ; <input checked="" type="checkbox"/> ±8KV <input type="checkbox"/> ±10 K ; <input type="checkbox"/> ±15KV	<input checked="" type="checkbox"/> Air	±10	B	Pass
HCP	<input checked="" type="checkbox"/> ±2 KV ; <input checked="" type="checkbox"/> ±4KV <input type="checkbox"/> ±6 KV ; <input type="checkbox"/> ±8KV <input type="checkbox"/> ±10 KV ; <input type="checkbox"/> ±15KV	<input checked="" type="checkbox"/> Contact	±25	B	Pass
VCP	<input checked="" type="checkbox"/> ±2 KV ; <input checked="" type="checkbox"/> ±4KV <input type="checkbox"/> ±6 KV ; <input type="checkbox"/> ±8KV <input type="checkbox"/> ±10 KV ; <input type="checkbox"/> ±15KV	<input checked="" type="checkbox"/> Contact	±25	B	Pass

* Comment:

- No degradation was found
- Phenomenon Description

Test products in the testing process did not appear performance degradation phenomenon, the product works well after the test.

Note:

- 1) N/A - denotes test is not applicable in this test report.

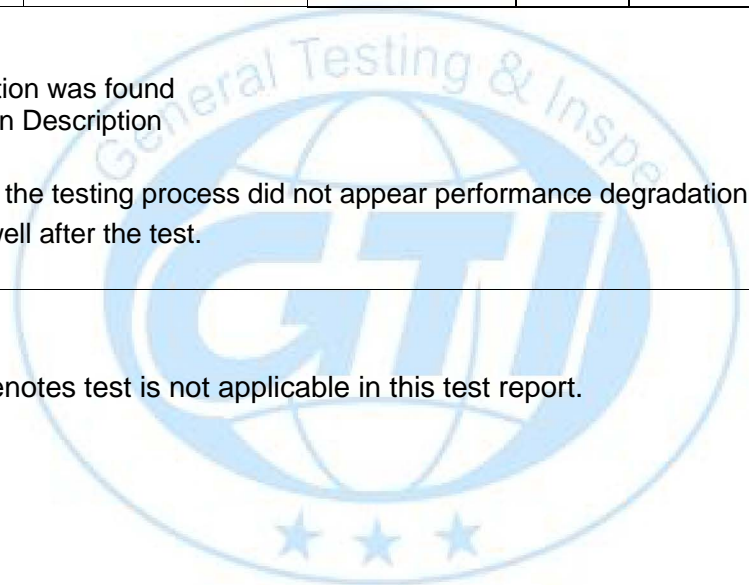

3.3. RF Electromagnetic Field

TEST SPECIFICATION

Basic Standard:	IEC/EN 61000-4-3
Required Performance	A
Frequency Range:	80 MHz - 1000 MHz , 1000MHz-2700MHz, 2700MHz-6000MHz
Field Strength:	3 V/m
Modulation:	1kHz Sine Wave, 80%, AM Modulation
Frequency Step:	1 % of fundamental
Polarity of Antenna:	Horizontal and Vertical
Test Distance:	3 m
Antenna Height:	1.5 m
Dwell Time:	at least 3 seconds

TEST PROCEDURE

The EUT and support equipment, which are placed on a table that is 0.8 meter above ground and the testing was performed in a fully-anechoic chamber. The testing distance from antenna to the EUT was 3 meters. The other condition as following manner:

- a) The field strength level was 3V/m.
- b) The frequency range is swept from 80 MHz to 1000 MHz, & 1400MHz - 2700MHz with the signal 80% amplitude modulated with a 1 kHz sine wave. The rate of sweep did not exceed 1.5×10^{-3} decade/s. Where the frequency range is swept incrementally, the step size was 1% of fundamental.
- c) Sweep Frequency 900 MHz, with the Duty Cycle:1/8 and Modulation: Pulse 217 Hz(if applicable)
- d) The dwell time at each frequency shall be not less than the time necessary for the EUT to be able to respond.
- e) The test was performed with the EUT exposed to both vertically and horizontally polarized fields on each of the four sides.
- f) For the actual test configuration, please refer to the related Item –EUT Test Photos.

TEST SETUP

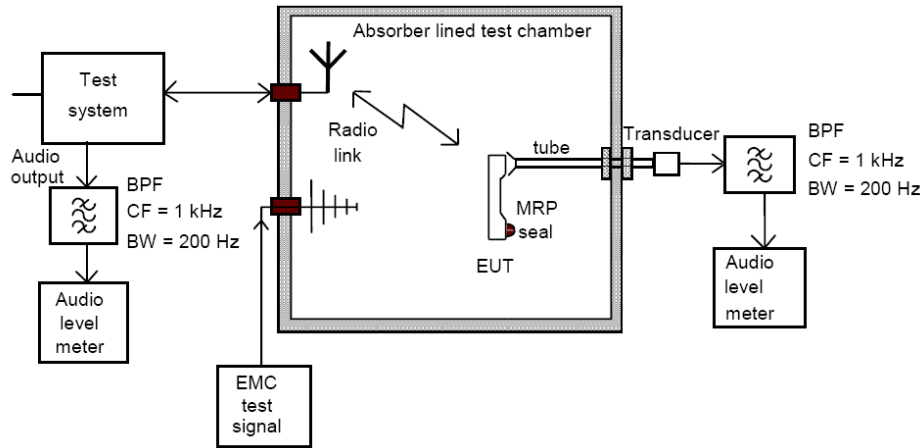

Note:

TABLE-TOP EQUIPMENT

The EUT installed in a representative system as described in section 7 of IEC/EN 61000-4-3 was placed on a non-conductive table 0.8 meters in height. The system under test was connected to the power and signal wire according to relevant installation instructions.

FLOOR-STANDING EQUIPMENT

The EUT installed in a representative system as described in section 7 of IEC/EN 61000-4-3 was placed on a non-conductive wood support 0.1 meters in height. The system under test was connected to the power and signal wire according to relevant installation instructions.

TEST RESULTS

Test Mode	Mode1
-----------	-------

EUT Position	Frequency range 1 80MHz-1000MHz Level:3V/m		Frequency range 2 1000MHz-2700MHz Level: 3V/m		Frequency range 3 2700MHz-6000MHz Level: 3V/m		Test Result
	Horiz- ontal	Verical	Horizo- ntal	Verical	Horizo- ntal	Verical	
from	A *	A *	A *	A *	A *	A *	Pass
right	A *	A *	A *	A *	A *	A *	Pass
back	A *	A *	A *	A *	A *	A *	Pass
left	A *	A *	A *	A *	A *	A *	Pass

* Comment:

- No degradation was found
- Phenomenon Description

Note:

- 1) N/A - denotes test is not applicable in this test report.

3.4. Fast Transients Common Mode

TEST SPECIFICATION

Basic Standard:	IEC/EN 61000-4-4
Required Performance	B
Test Voltage:	Power Line:1 Kv Signal/Control Line:0.5 KV
Polarity:	Positive & Negative
Impulse Frequency:	5 kHz
Impulse Wave shape :	5/50 ns
Burst Duration:	15 ms
Burst Period:	300 ms
Test Duration:	Not less than 1 min.

TEST PROCEDURE

The EUT and support equipment, are placed on a table that is 0.8 meter above a metal ground plane measured 1m*1m min. and 0.65mm thick min. The other condition as following manner:

- The length of power cord between the coupling device and the EUT should not exceed 1 meter.
- Both positive and negative polarity discharges were applied.
- The duration time of each test sequential was 1 minute
- For the actual test configuration, please refer to the related Item –EUT Test Photos.

EST SETUP

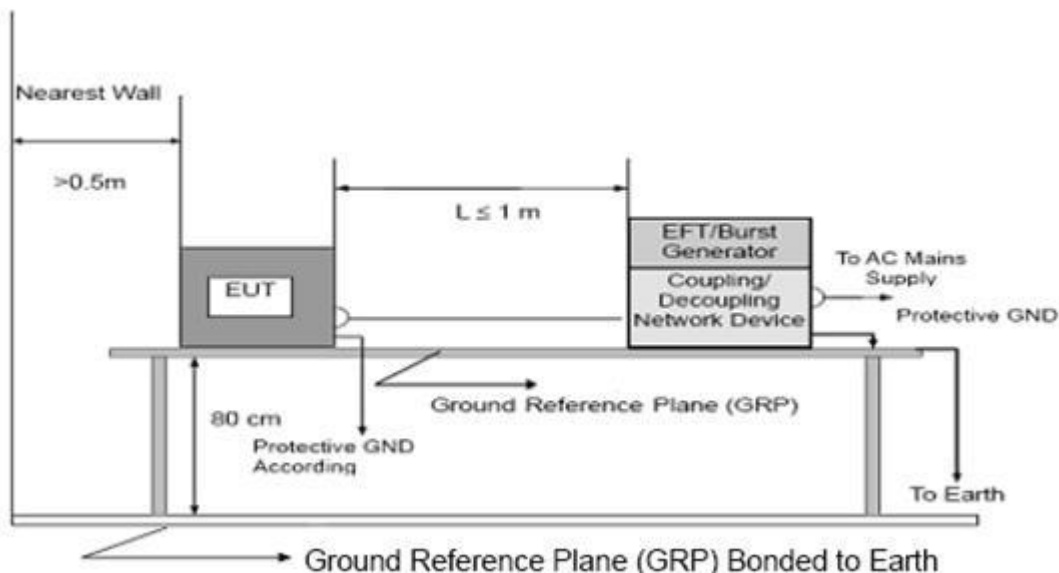

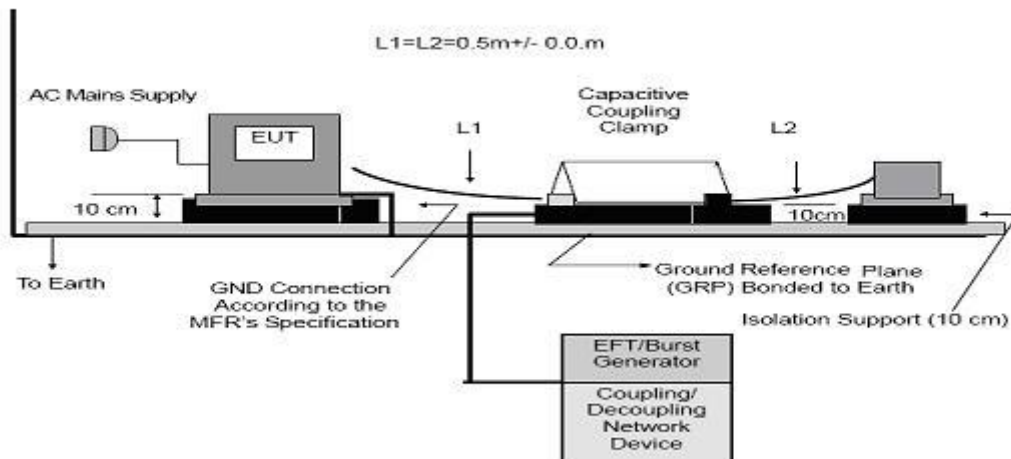

Note:

TABLE-TOP EQUIPMENT

The configuration consisted of a wooden table (0.8m high) standing on the Ground Reference Plane. The GRP consisted of a sheet of aluminum (at least 0.25mm thick and 2.5m square) connected to the protective grounding system. A minimum distance of 0.5m was provided between the EUT and the walls of the laboratory or any other metallic structure.

FLOOR-STANDING EQUIPMENT

The EUT installed in a representative system as described in section 7 of IEC/EN 61000-4-4 and its cables, were isolated from the Ground Reference Plane by an insulating support that is 0.1-meter thick. The GRP consisted of a sheet of aluminum (at least 0.25mm thick and 2.5m square) connected to the protective grounding system.

TEST RESULTS

The test is not applicable in this Test Report .

3.5. SURGE Testing

TEST SPECIFICATION

Basic Standard:	IEC/EN 61000-4-5
Required Performance	B
Wave-Shape:	Combination Wave 1.2/50 us Open Circuit Voltage 8 /20 us Short Circuit Current
Test Voltage:	Power Line: ± 1 Kv RJ45 Line: ± 0.5 Kv
Surge Input /Output:	L1-L2, RJ45
Generator Source:	2 ohm between networks
Impedance:	12 ohm between network and ground
Polarity:	Positive/Negative
Phase Angle:	0 /90/180/270
Pulse Repetition Rate:	1 time / min. (maximum)
Number of Tests:	5 positive and 5 negative at selected points

TEST PROCEDURE

- a) For EUT power supply:
The surge is to be applied to the EUT power supply terminals via the capacitive coupling network. Decoupling networks are required in order to avoid possible adverse effects on equipment not under test that may be powered by the same lines, and to provide sufficient decoupling impedance to the surge wave. The power cord between the EUT and the coupling/decoupling networks shall be 2meters in length (or shorter).
- b) For test applied to unshielded unsymmetrical operated interconnection lines of EUT:
The surge is applied to the lines via the capacitive coupling. The coupling /decoupling networks shall not influence the specified functional conditions of the EUT. The interconnection line between the EUT and the coupling/decoupling networks shall be 2 meters in length (or shorter).
- c) For test applied to unshielded symmetrically operated interconnection /telecommunication lines of EUT: The surge is applied to the lines via gas arrestors coupling. Test levels below the ignition point of the coupling arrestor cannot be specified. The interconnection line between the EUT and the coupling/decoupling networks shall be 2 meters in length (or shorter).
- d) For the actual test configuration, please refer to the related Item –EUT Test Photos.

TEST SETUP

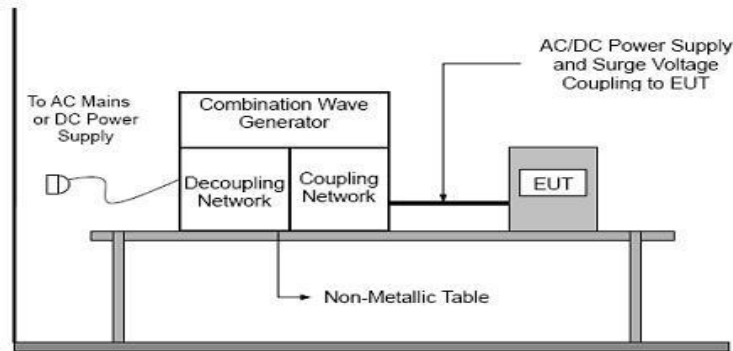

TEST RESULTS

The test is not applicable in this Test Report .

3.6. RF Common Mode

TEST SPECIFICATION

Basic Standard:	IEC/EN 61000-4-6
Required Performance	A
Frequency Range:	0.15 MHz - 80 MHz
Field Strength:	3 V rms
Modulation:	1kHz Sine Wave, 80%, AM Modulation
Frequency Step:	1 % of fundamental
Dwell Time:	at least 3 seconds

TEST PROCEDURE

The EUT and support equipment, are placed on a table that is 0.8 meter above a metal ground plane measured 1m*1m min. and 0.65mm thick min. The other condition as following manner:

- a) The field strength level was 3V.
- b) The frequency range is swept from 150 KHz to 80 MHz, with the signal 80%amplitude modulated with a 1kHz sine wave. The rate of sweep did not exceed 1.5x 10⁻³ decade/s. Where the frequency range is swept incrementally, the step size was 1% of fundamental.
- c) The dwell time at each frequency shall be not less than the time necessary for the EUT to be able to respond.
- d) For the actual test configuration, please refer to the related Item –EUT Test Photos.

TEST SETUP

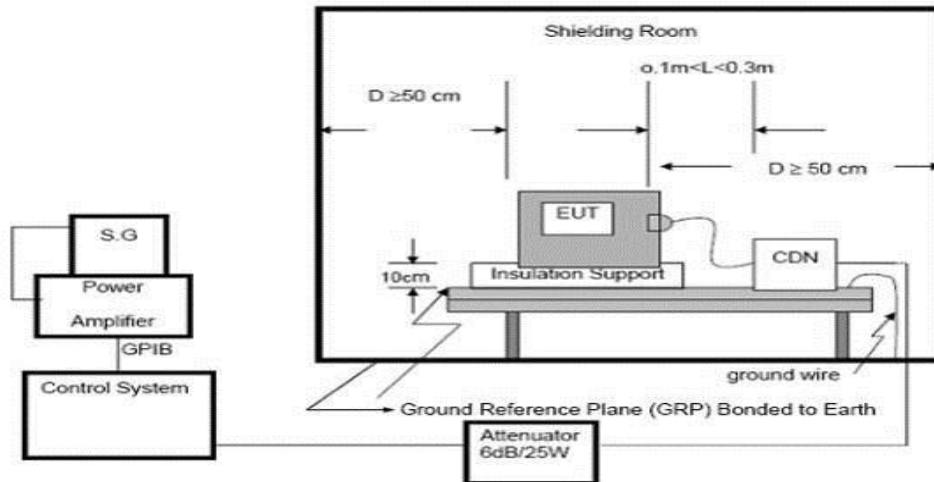

For the actual test configuration, please refer to the related Item –EUT Test Photos.

NOTE:

FLOOR-STANDING EQUIPMENT

The equipment to be tested is placed on an insulating support of 0.1 meters height above a ground reference plane. All relevant cables shall be provided with the appropriate coupling and decoupling devices at a distance between 0.1 meters and 0.3 meters from the projected geometry of the EUT on the ground reference plane.

TEST RESULTS

The test is not applicable in this Test Report .

3.7. Voltage Dips and Interruptions

TEST SPECIFICATION

Basic Standard:	IEC/EN 61000-4-11
Required Performance	B (For 0% Voltage Dips) C (For 70% Voltage Dips) C (For 0% Voltage Interruptions)
Test Duration Time:	Minimum three test events in sequence
Interval between Event:	Minimum ten seconds
Phase Angle:	0°/45°/90°/135°/180°/225°/270°/315°/360°
Test Cycle:	3 times

TEST PROCEDURE

The EUT shall be tested for each selected combination of test levels and duration with a sequence of three dips/interruptions with intervals of 10 s minimum (between each test event). Each representative mode of operation shall be tested. Abrupt changes in supply voltage shall occur at zero crossings of the voltage waveform.

TEST SETUP

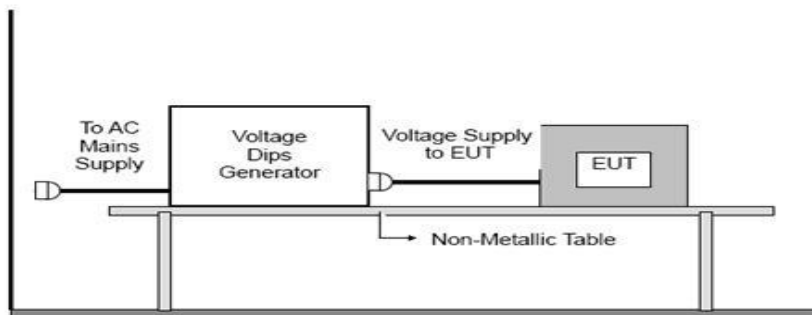

For the actual test configuration, please refer to the related Item –EUT Test Photos.

TEST RESULTS

The test is not applicable in this Test Report .

4. EUT TEST PHOTO

Radiated Measurement (30MHz~1000MHz)



Radiated Measurement (1000~6000MHz)

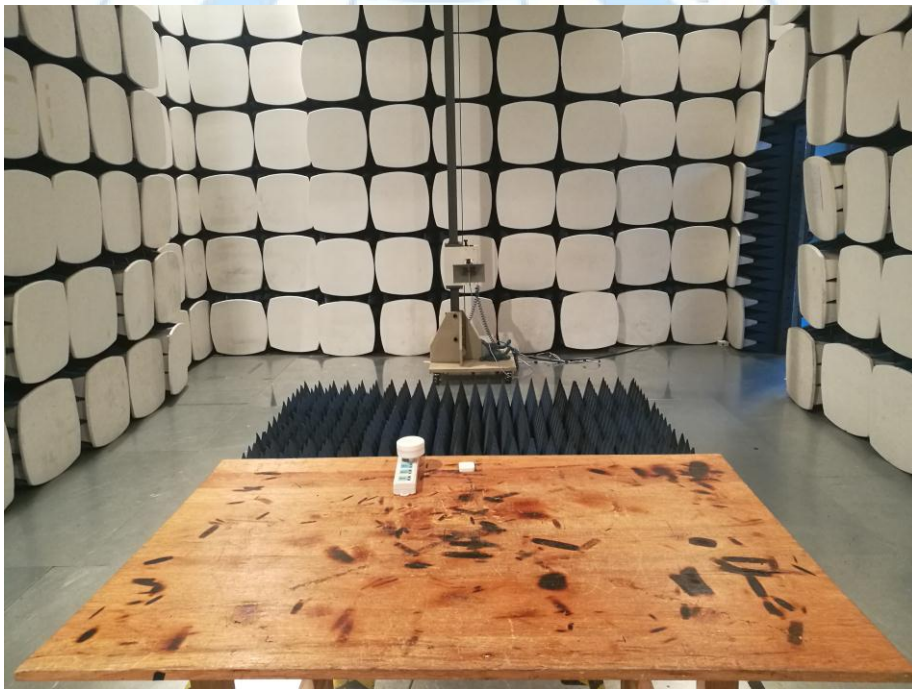

Electrostatic Discharge



RF electromagnetic field



5. PHOTOGRAPHS OF EUT CONSTRUCTIONAL

1. Photo

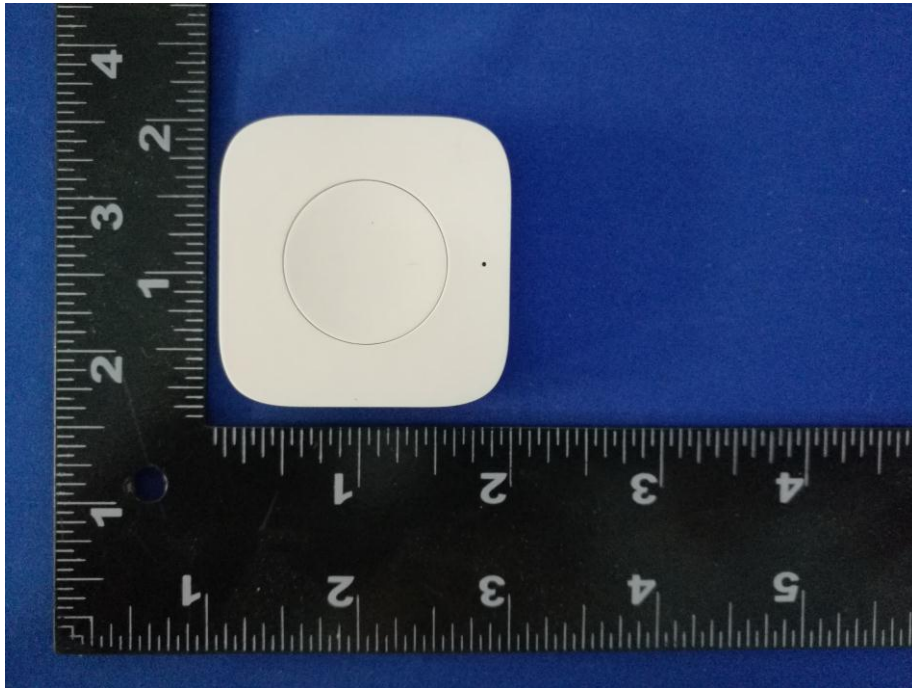

2. Photo



3. Photo

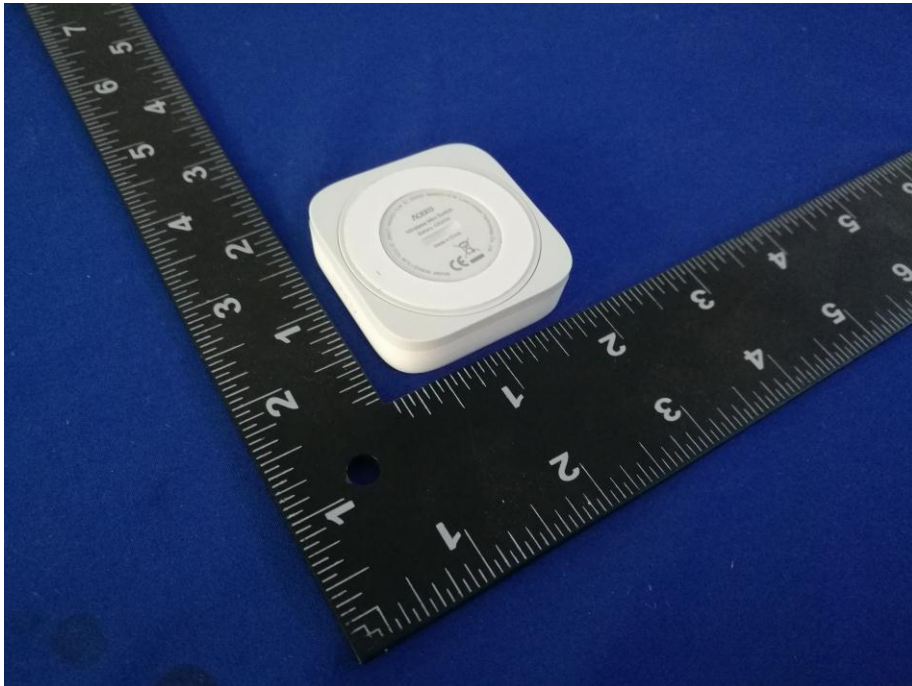

4. Photo

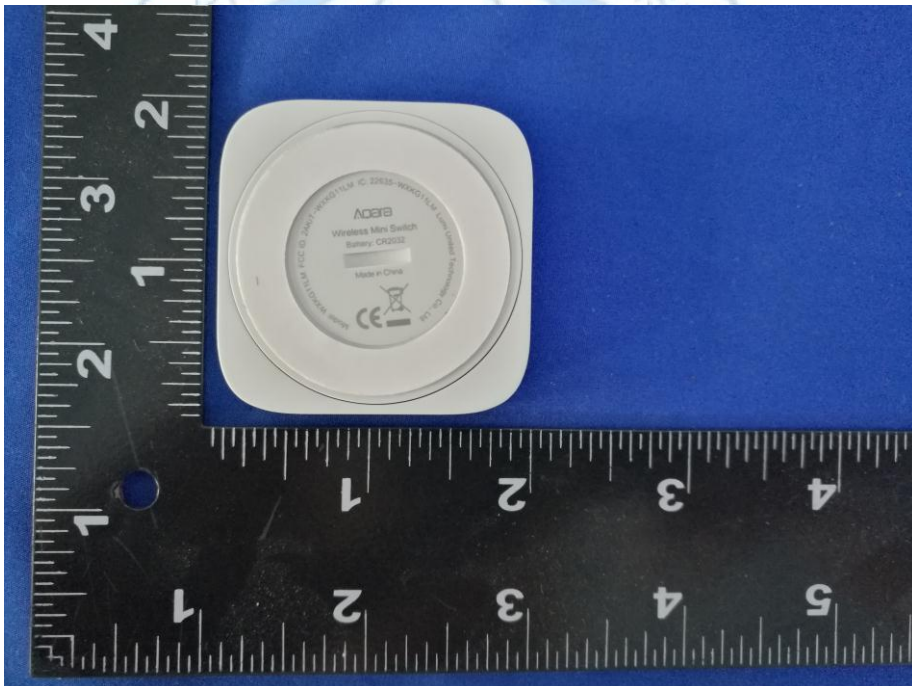

5. Photo



6. Photo

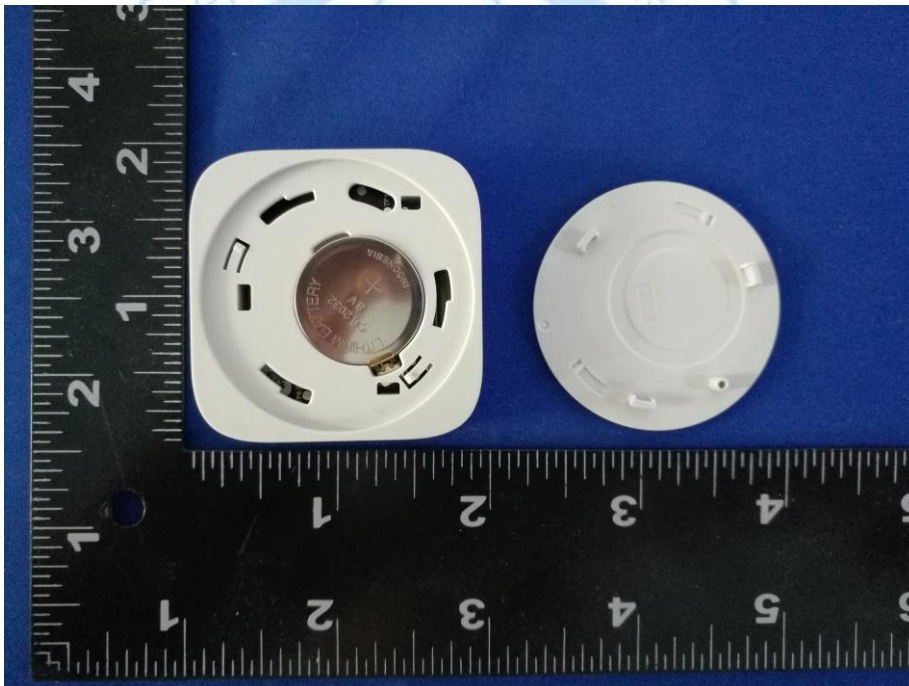

7. Photo

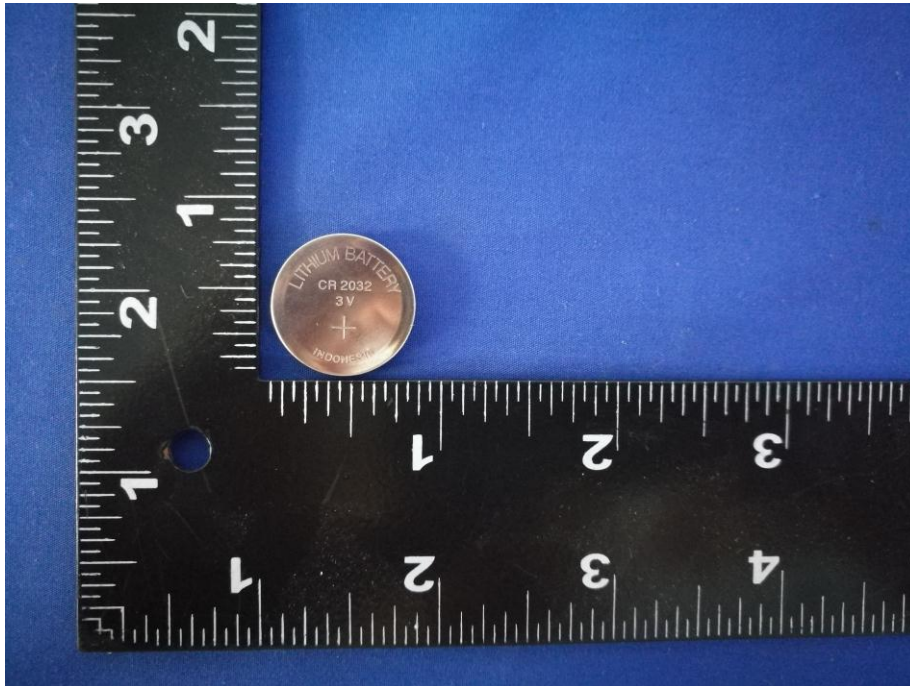

8. Photo

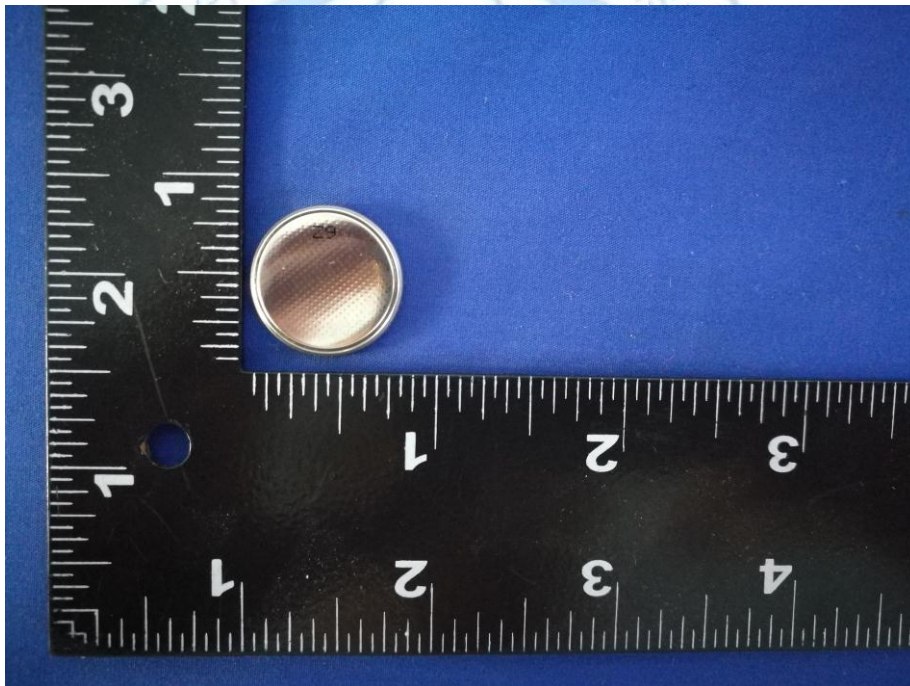

9. Photo

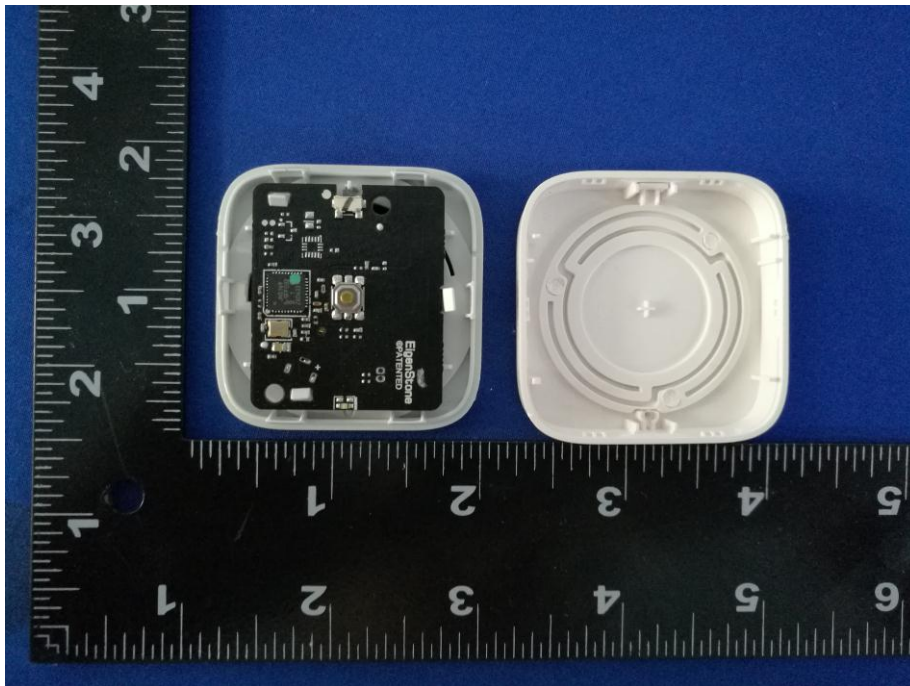

10. Photo

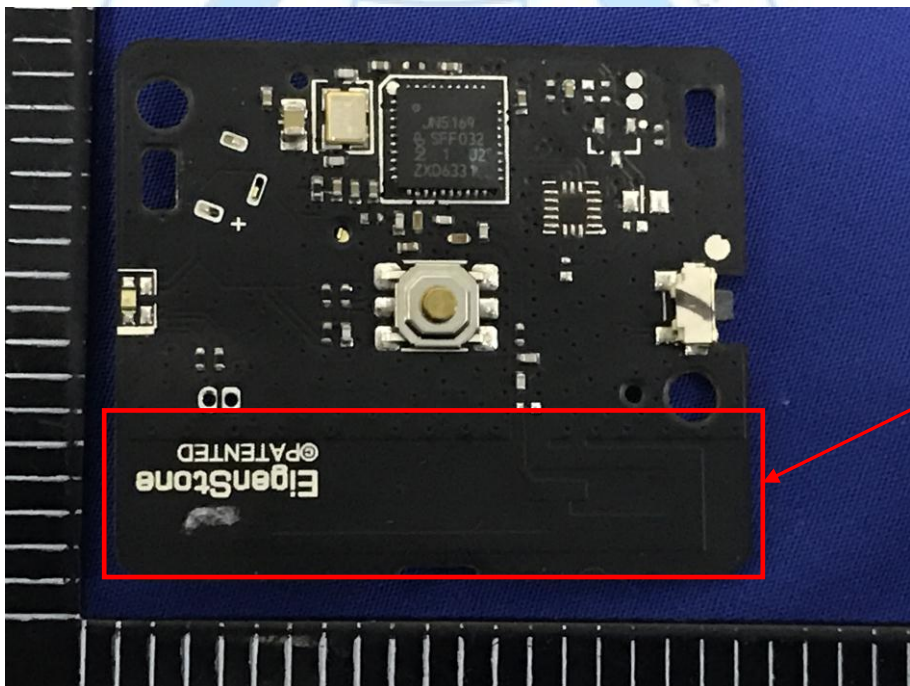

Antenna

11. Photo

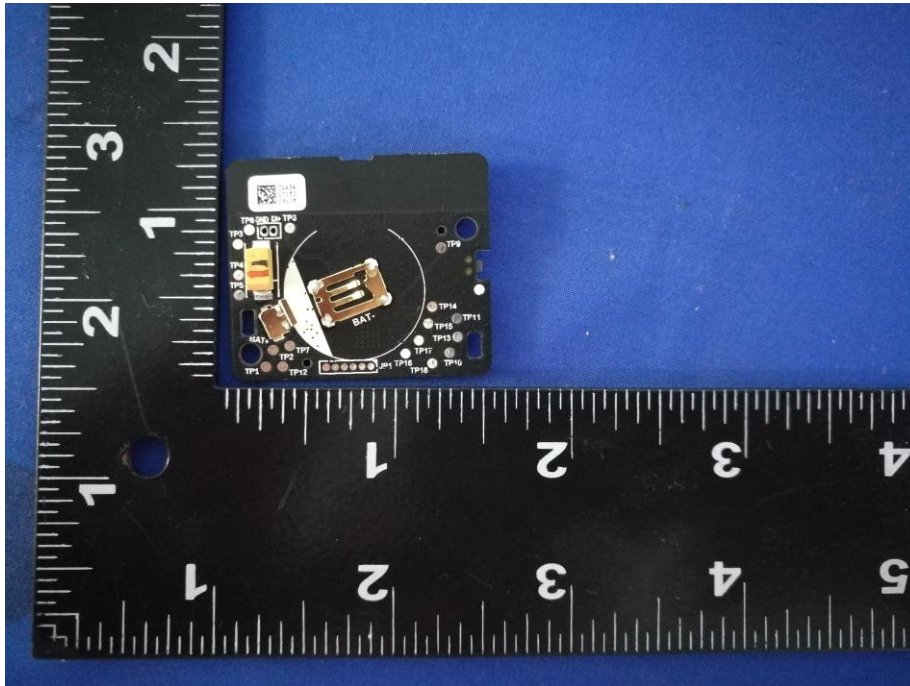

*****THE END*****

