

---

# EMC Test Report

---

Report No.: AGC00550220603EE01

**PRODUCT DESIGNATION** : smartwatch

**BRAND NAME** : Blackview, IOWODO, FeipuQu

**MODEL NAME** : R1, R10, R10Pro, R20, R20Pro, R30, R30Pro, R40, R40Pro,  
R50, R50Pro, R60, R60Pro, R70, R70Pro, R80, R80Pro, R90,  
R90Pro

**APPLICANT** : Shenzhen Hairuichuang Technology Co., Ltd.

**DATE OF ISSUE** : Aug. 03, 2022

**STANDARD(S)** : ETSI EN 301 489-1 V2.2.3 (2019-11)  
ETSI EN 301 489-17 V3.2.4 (2020-09)

**REPORT VERSION** : V1.0



Attestation of Global Compliance (Shenzhen) Co., Ltd

Any report having not been signed by authorized approver, or having been altered without authorization, or having not been stamped by the "Dedicated Testing/Inspection Stamp" is deemed to be invalid. Copying or excerpting portion of, or altering the content of the report is not permitted without the written authorization of AGC. The test results presented in the report apply only to the tested sample. Any objections to report issued by AGC should be submitted to AGC within 15days after the issuance of the test report. Further enquiry of validity or verification of the test report should be addressed to AGC by [agc01@agccert.com](mailto:agc01@agccert.com).



### REPORT REVISE RECORD

Report Version	Revise Time	Issued Date	Valid Version	Notes
V1.0	/	Aug. 03, 2022	Valid	Initial release

Any report having not been signed by authorized approver, or having been altered without authorization, or having not been stamped by the "Dedicated Testing/Inspection Stamp" is deemed to be invalid. Copying or excerpting portion of, or altering the content of the report is not permitted without the written authorization of AGC. The test results presented in the report apply only to the tested sample. Any objections to report issued by AGC should be submitted to AGC within 15days after the issuance of the test report. Further enquiry of validity or verification of the test report should be addressed to AGC by [agc01@agccert.com](mailto:agc01@agccert.com).

## TABLE OF CONTENTS

<b>1. TEST REPORT CERTIFICATION .....</b>	<b>6</b>
<b>2. GENERAL INFORMATION .....</b>	<b>7</b>
2.1. DESCRIPTION OF EUT .....	7
2.2. OBJECTIVE .....	8
2.3. TEST STANDARDS AND RESULTS .....	8
2.4. TEST ITEMS AND THE RESULTS .....	8
2.5. ENVIRONMENTAL CONDITIONS.....	9
<b>3. TEST MODE DESCRIPTION.....</b>	<b>10</b>
<b>4. MEASUREMENT UNCERTAINTY .....</b>	<b>11</b>
<b>5. SUPPORT EQUIPMENT .....</b>	<b>11</b>
<b>6. IDENTIFICATION OF THE RESPONSIBLE TESTING LOCATION.....</b>	<b>12</b>
<b>7. RADIATED DISTURBANCE MEASUREMENT .....</b>	<b>14</b>
7.1. LIMITS OF RADIATED DISTURBANCES .....	14
7.2. TEST PROCEDURE .....	14
7.3. BLOCK DIAGRAM OF TEST SETUP .....	15
7.4. TEST RESULT .....	16
<b>8. MAINS TERMINAL DISTURBANCE VOLTAGE MEASUREMENT .....</b>	<b>20</b>
8.1. LIMITS OF MAINS TERMINAL DISTURBANCE VOLTAGE.....	20
8.2. TEST PROCEDURE.....	20
8.3. TEST SETUP.....	21
8.4. TEST RESULT.....	21
<b>9. HARMONIC CURRENT MEASUREMENT .....</b>	<b>24</b>
9.1. LIMITS OF HARMONIC CURRENT .....	24
9.2. TEST PROCEDURE.....	24
9.3. TEST SETUP.....	25
9.4. TEST RESULT.....	25
<b>10. VOLTAGE FLUCTUATIONS AND FLICK MEASUREMENT .....</b>	<b>26</b>
10.1. LIMITS OF VOLTAGE FLUCTUATIONS AND FLICK.....	26
10.2. TEST PROCEDURE .....	26

Any report having not been signed by authorized approver, or having been altered without authorization, or having not been stamped by the “Dedicated Testing/Inspection Stamp” is deemed to be invalid. Copying or excerpting portion of, or altering the content of the report is not permitted without the written authorization of AGC. The test results presented in the report apply only to the tested sample. Any objections to report issued by AGC should be submitted to AGC within 15days after the issuance of the test report. Further enquiry of validity or verification of the test report should be addressed to AGC by [agc01@agccert.com](mailto:agc01@agccert.com).

10.3. TEST SETUP.....	26
10.4. TEST RESULT.....	26
<b>11. IMMUNITY TEST.....</b>	<b>27</b>
11.1. DESCRIPTION OF PERFORMANCE CRITERIA.....	27
11.2. GENERAL PERFORMANCE CRITERIA .....	27
<b>12. ELECTROSTATIC DISCHARGE IMMUNITY TEST .....</b>	<b>29</b>
12.1 TEST SPECIFICATION .....	29
12.2 TEST PROCEDURE.....	29
12.3 TEST SETUP .....	30
12.4 TEST RESULT .....	30
12.5 PERFORMANCE .....	31
<b>13. RADIATED, RADIO FREQUENCY ELECTROMAGNETIC FIELD IMMUNITY TEST.....</b>	<b>33</b>
13.1. TEST SPECIFICATION .....	33
13.2. TEST PROCEDURE .....	33
13.3. TEST SETUP.....	34
13.4. TEST RESULT.....	35
13.5. PERFORMANCE.....	35
<b>14. ELECTRICAL FAST TRANSIENT/BURST IMMUNITY TEST.....</b>	<b>36</b>
14.1. TEST SPECIFICATION .....	36
14.2. TEST PROCEDURE .....	36
14.3. TEST SETUP.....	36
14.4. TEST RESULT.....	37
14.5. PERFORMANCE.....	37
<b>15. SURGE IMMUNITY TEST .....</b>	<b>38</b>
15.1. TEST SPECIFICATION .....	38
15.2. TEST PROCEDURE .....	38
15.3. TEST SETUP.....	38
15.4. TEST RESULT.....	39
15.5. PERFORMANCE.....	39
<b>16. IMMUNITY TO CONDUCTED DISTURBANCES INDUCED BY RF FIELDS.....</b>	<b>40</b>
16.1. TEST SPECIFICATION .....	40
16.2. TEST PROCEDURE .....	40

Any report having not been signed by authorized approver, or having been altered without authorization, or having not been stamped by the “Dedicated Testing/Inspection Stamp” is deemed to be invalid. Copying or excerpting portion of, or altering the content of the report is not permitted without the written authorization of AGC. The test results presented in the report apply only to the tested sample. Any objections to report issued by AGC should be submitted to AGC within 15days after the issuance of the test report. Further enquiry of validity or verification of the test report should be addressed to AGC by agc01@agccert.com.

16.3. TEST SETUP..... 40

16.4. TEST RESULT..... 41

16.5. PERFORMANCE..... 41

**17. VOLTAGE DIPS AND SHORT INTERRUPTIONS IMMUNITY TEST ..... 42**

17.1. TEST SPECIFICATION ..... 42

17.2. TEST PROCEDURE ..... 42

17.3. TEST SETUP..... 42

17.4. TEST RESULT..... 43

17.5. PERFORMANCE..... 43

**APPENDIX A: PHOTOGRAPHS OF TEST SETUP ..... 44**

**APPENDIX B: PHOTOGRAPHS OF EUT ..... 49**

Any report having not been signed by authorized approver, or having been altered without authorization, or having not been stamped by the “Dedicated Testing/Inspection Stamp” is deemed to be invalid. Copying or excerpting portion of, or altering the content of the report is not permitted without the written authorization of AGC. The test results presented in the report apply only to the tested sample. Any objections to report issued by AGC should be submitted to AGC within 15days after the issuance of the test report. Further enquiry of validity or verification of the test report should be addressed to AGC by [agc01@agccert.com](mailto:agc01@agccert.com).

## 1. TEST REPORT CERTIFICATION

<b>Applicant</b>	Shenzhen Hairuichuang Technology Co., Ltd.
<b>Address</b>	Room 2001, Building A, Weidonglong Business Building, No. 2125, Meilong Avenue, Longhua District, Shenzhen, China
<b>Manufacturer</b>	Shenzhen Hairuichuang Technology Co., Ltd.
<b>Address</b>	Room 2001, Building A, Weidonglong Business Building, No. 2125, Meilong Avenue, Longhua District, Shenzhen, China
<b>Factory</b>	Shenzhen Hairuichuang Technology Co., Ltd.
<b>Address</b>	Room 2001, Building A, Weidonglong Business Building, No. 2125, Meilong Avenue, Longhua District, Shenzhen, China
<b>Product Designation</b>	smartwatch
<b>Brand Name</b>	Blackview, IOWODO, FeipuQu
<b>Test Model</b>	R1
<b>Series Model</b>	R10, R10Pro, R20, R20Pro, R30, R30Pro, R40, R40Pro, R50, R50Pro, R60, R60Pro, R70, R70Pro, R80, R80Pro, R90, R90Pro
<b>Difference description</b>	All the series models are the same as the test model except for the model names.
<b>Date of test</b>	Jul. 25, 2022 to Aug. 03, 2022
<b>Deviation</b>	None
<b>Condition of Test Sample</b>	Normal
<b>Test Result</b>	Pass
<b>Report Template</b>	AGCRT-EC-EMC

We, Attestation of Global Compliance (Shenzhen) Co., Ltd., hereby certify that the submitted samples of the above item, as detailed in chapter 2.1 of this report, has been tested in our facility. The test record, data evaluation and test configuration represented herein are true and accurate accounts of measurements of the sample's EMC characteristics under the conditions herein specified.

Prepared By   
 Bibo Zhang  
 (Project Engineer) Aug. 03, 2022

Reviewed By   
 Calvin Liu  
 (Reviewer) Aug. 03, 2022

Approved By   
 Max Zhang  
 (Authorized Officer) Aug. 03, 2022

Any report having not been signed by authorized approver, or having been altered without authorization, or having not been stamped by the "Dedicated Testing/Inspection Stamp" is deemed to be invalid. Copying or excerpting portion of, or altering the content of the report is not permitted without the written authorization of AGC. The test results presented in the report apply only to the tested sample. Any objections to report issued by AGC should be submitted to AGC within 15days after the issuance of the test report. Further enquiry of validity or verification of the test report should be addressed to AGC by agc01@agccert.com.

## 2. GENERAL INFORMATION

### 2.1. DESCRIPTION OF EUT

Details of technical specification refer to the description in follows:

Transmitter/Receiver (TX/RX)

<b>Operating Frequency</b>	2.402 GHz to 2.480GHz
<b>Modulation</b>	BR: <input type="checkbox"/> GFSK, EDR: <input type="checkbox"/> $\pi$ /4-DQPSK, <input type="checkbox"/> 8DPSK BLE: <input checked="" type="checkbox"/> GFSK 1Mbps <input type="checkbox"/> GFSK 2Mbps
<b>Bluetooth Version</b>	V5.0
<b>Hardware Version</b>	V02
<b>Software Version</b>	V1.0
<b>Antenna designation</b>	FPC Antenna
<b>Number of channels</b>	40
<b>Antenna Gain</b>	-6.91dBi
<b>Power Supply</b>	DC 3.7V by battery or DC 5V by adapter

Any report having not been signed by authorized approver, or having been altered without authorization, or having not been stamped by the "Dedicated Testing/Inspection Stamp" is deemed to be invalid. Copying or excerpting portion of, or altering the content of the report is not permitted without the written authorization of AGC. The test results presented in the report apply only to the tested sample. Any objections to report issued by AGC should be submitted to AGC within 15days after the issuance of the test report. Further enquiry of validity or verification of the test report should be addressed to AGC by agc01@agccert.com.

Attestation of Global Compliance(Shenzhen)Co., Ltd

Attestation of Global Compliance(Shenzhen)Std & Tech Co., Ltd

Tel: +86-755 2523 4088 E-mail: agc@agccert.com Web: <http://www.agccert.com/>

## 2.2. OBJECTIVE

Perform Electro Magnetic Interference (EMI) and Electro Magnetic Susceptibility (EMS) tests for CE Marking.

## 2.3. TEST STANDARDS AND RESULTS

The EUT has been tested according to ETSI EN 301 489-1 V2.2.3 (2019-11) and ETSI EN 301 489-17 V3.2.4 (2020-09).

<b>ETSI EN 301 489-1</b>	ElectroMagnetic Compatibility (EMC) standard for radio equipment and services; Part 1: Common technical requirements; Harmonised Standard for ElectroMagnetic Compatibility.
<b>ETSI EN 301 489-17</b>	ElectroMagnetic Compatibility (EMC) standard for radio equipment and services; Part 17: Specific conditions for Broadband Data Transmission Systems; Harmonised Standard for ElectroMagnetic Compatibility

## 2.4. TEST ITEMS AND THE RESULTS

No.	Basic Standard	Test Type	Result
<b>EMISSION (EN 301 489-1 §7.1)</b>			
1	EN 55032	Radiated emission	PASS
2	EN 55032	Conducted emission, AC ports	PASS
3	EN 55032	Conducted emission, Telecom ports	N/A
4	EN 61000-3-2	Harmonic current emissions	N/A
5	EN 61000-3-3	Voltage fluctuations & flicker	PASS
<b>IMMUNITY (EN 301 489-1 §7.2)</b>			
6	EN 61000-4-2	Electrostatic discharge immunity	PASS
7	EN 61000-4-3	Radiated RF electromagnetic field immunity	PASS
8	EN 61000-4-4	Electrical fast transient/burst immunity	PASS
9	ISO 7637-1, -2	Transients and surges, DC ports	N/A
10	EN 61000-4-5	Surge immunity, AC ports, Telecom ports	PASS
11	EN 61000-4-6	Immunity to conducted disturbances induced by RF fields	PASS
12	EN 61000-4-11	Voltage dips and short interruptions immunity	PASS

Note: 1. N/A- Not Applicable.

2. The latest versions of basic standards are applied.



## 2.5. ENVIRONMENTAL CONDITIONS

During the measurement the environmental conditions were within the listed ranges:

- Temperature: 15-35°C
- Relative humidity: 30-60 %
- Atmospheric pressure: 86-106 kPa

Any report having not been signed by authorized approver, or having been altered without authorization, or having not been stamped by the "Dedicated Testing/Inspection Stamp" is deemed to be invalid. Copying or excerpting portion of, or altering the content of the report is not permitted without the written authorization of AGC. The test results presented in the report apply only to the tested sample. Any objections to report issued by AGC should be submitted to AGC within 15days after the issuance of the test report. Further enquiry of validity or verification of the test report should be addressed to AGC by [agc01@agccert.com](mailto:agc01@agccert.com).

Attestation of Global Compliance(Shenzhen)Co., Ltd  
Attestation of Global Compliance(Shenzhen)Std & Tech Co., Ltd  
Tel: +86-755 2523 4088 E-mail: [agc@agccert.com](mailto:agc@agccert.com) Web: <http://www.agccert.com/>

### 3. TEST MODE DESCRIPTION

TEST MODE DESCRIPTION		
NO.	EMI TEST MODE DESCRIPTION	WORST
1	Charging+BT Mode	V
2	BT Mode	-
NO.	EMS TEST MODE DESCRIPTION	WORST
1	Charging+BT Mode	V
2	BT Mode	-

Note: 1. V means EMI worst mode.  
2. All modes have been tested and only the worst mode test data recorded in the test report.

I/O Port Information (Applicable Not Applicable)

I/O Port of EUT			
I/O Port Type	Number	Cable Description	Tested With
--	--	--	--

Note: All the above "--" means that EUT has no cable.

#### 4. MEASUREMENT UNCERTAINTY

The uncertainty is calculated using the methods suggested in the “Guide to the Expression of Uncertainty in measurement” (GUM) published by CISPR and ANSI.

- Uncertainty of Radiated Emission,  $U_c = \pm 2.9\text{dB}$
- Uncertainty of Radiated Emission below 1GHz,  $U_c = 3.8\text{ dB}$
- Uncertainty of Radiated Emission above 1GHz,  $U_c = \pm 4.9\text{ dB}$

#### 5. SUPPORT EQUIPMENT

Device Type	Manufacturer	Model Name	Data Cable
adapter	jinbaotong	K-T10E0502000E	--
Xiaomi phone	Xiaomi	Mi 10	--

- Note: 1.“--” means no any support device during testing.  
2. All the cables were provided by AGC Lab.

## 6. IDENTIFICATION OF THE RESPONSIBLE TESTING LOCATION

<b>Site</b>	Attestation of Global Compliance (Shenzhen) Co., Ltd
<b>Location</b>	1-2/F, Building 19, Junfeng Industrial Park, Chongqing Road, Heping Community, Fuhai Street, Bao'an District, Shenzhen, Guangdong, China

### TEST EQUIPMENT OF CONDUCTED EMISSION TEST

Equipment	Manufacturer	Model	S/N	Cal. Date	Cal. Due
Test Receiver	R&S	ESPI	101206	Mar. 28, 2022	Mar. 27, 2023
LISN	R&S	ESH2-Z5	100086	Jun. 08, 2022	Jun. 07, 2023

### TEST EQUIPMENT OF RADIATED EMISSION TEST

Equipment	Manufacturer	Model	S/N	Cal. Date	Cal. Due
Test Receiver	R&S	ESCI	10096	Mar. 28, 2022	Mar. 27, 2023
ANTENNA	SCHWARZBECK	VULB9168	494	Jan. 08, 2021	Jan. 07, 2023
Double-Ridged Waveguide Horn	ETS LINDGREN	3117	00034609	Apr. 23, 2021	Apr. 22, 2023
EXA Signal Analyzer	Aglient	N9010A	MY53470504	Nov. 17, 2021	Nov. 16, 2022

### TEST EQUIPMENT OF ESD TEST

Equipment	Manufacturer	Model	S/N	Cal. Date	Cal. Due
ESD Simulator	EM Test	NSG 438	782	Jan. 03, 2022	Jan. 02, 2023

### TEST EQUIPMENT OF POWER HARMONICS / VOLTAGE FLUCTUATION / FLICKER TEST

Equipment	Manufacturer	Model	S/N	Cal. Date	Cal. Due
Signal Conditioning Unit	Schaffner	CCN1000-1	72431	Jun. 23,2022	Jun. 22,2023
AC Source	Schaffner	NSG 1007	56825	Jun. 08,2022	Jun. 07,2023

### TEST EQUIPMENT OF SURGE/EFT/DIPSTEST

Equipment	Manufacturer	Model	S/N	Cal. Date	Cal. Due
EFT Surge Generator	Schaffner	Modula 6150	34437	Jun. 23,2022	Jun. 22,2023

Any report having not been signed by authorized approver, or having been altered without authorization, or having not been stamped by the "Dedicated Testing/Inspection Stamp" is deemed to be invalid. Copying or excerpting portion of, or altering the content of the report is not permitted without the written authorization of AGC. The test results presented in the report apply only to the tested sample. Any objections to report issued by AGC should be submitted to AGC within 15days after the issuance of the test report. Further enquiry of validity or verification of the test report should be addressed to AGC by agc01@agccert.com.

**TEST EQUIPMENT OF RS IMMUNITY TEST**

Equipment	Manufacturer	Model	S/N	Cal. Date	Cal. Due
Signal Generator	R&S	E4421B	MY43351603	Mar. 04, 2022	Mar. 03, 2023
POWER SENSOR	R&S	URV5-Z4	100124	Apr. 26, 2021	Apr. 25, 2023
POWER METER	R&S	NRVD	8323781027	Apr. 26, 2021	Apr. 25, 2023
POWER AMPLIFIER	KALMUS	7100LC	04-02/17-06-001	N/A	N/A
RF AMPLIFIER	Milmega	AS0104-55_55	1004793	N/A	N/A
Double-Ridged Waveguide Horn	ETS LINDGREN	3117	00034609	Apr. 23, 2021	Apr. 22, 2023
ANTENNA	SCHWARZBECK	VULB9168	494	Jan. 08,2021	Jan. 07,2023

**TEST EQUIPMENT OF CS IMMUNITY TEST**

Equipment	Manufacturer	Model	S/N	Cal. Date	Cal. Due
Power Amplifier	AR	75A250	18464	N/A	N/A
CDN	ZHINAN	ZN3751	15004	Sep. 03, 2020	Sep. 02, 2022
6dB attenuator	ZHINAN	E-002	N/A	Sep. 03, 2020	Sep. 02, 2022
Electromagnetic Injection Clamp	Luthi	EM101	35773	Aug. 25,2020	Aug. 24,2022
Power Sensor	R&S	URV5-Z4	100124	Apr. 26, 2021	Apr. 25, 2023
Power Meter	R&S	NRVD	8323781027	Apr. 26, 2021	Apr. 25, 2023
SIGNAL GENERATOR	R&S	E4421B	MY43351603	Mar. 04, 2022	Mar. 03, 2023

Any report having not been signed by authorized approver, or having been altered without authorization, or having not been stamped by the “Dedicated Testing/Inspection Stamp” is deemed to be invalid. Copying or excerpting portion of, or altering the content of the report is not permitted without the written authorization of AGC. The test results presented in the report apply only to the tested sample. Any objections to report issued by AGC should be submitted to AGC within 15days after the issuance of the test report. Further enquiry of validity or verification of the test report should be addressed to AGC by agc01@agccert.com.

## 7. RADIATED DISTURBANCE MEASUREMENT

### 7.1. LIMITS OF RADIATED DISTURBANCES

Limits for radiated disturbance 30M to1 GHz at a measurement distance of 3 m

Frequency range (MHz)	Quasi peak limits(dBuV/m), for Class B ITE, at 3m measurement distance
30 - 230	40
230 - 1000	47

Limits for radiated disturbance above 1 GHz at a measurement distance of 3 m

Frequency range (MHz)	Limits (dBuV/m), Class B ITE	
	Peak	Average
1000-3000MHz	70	50
3000-6000MHz	74	54

Note: 1. The lower limit shall apply at the transition frequency.

2. Additional provisions may be required for cases where interference occurs.

### 7.2. TEST PROCEDURE

- (1). The EUT was placed on the top of an insulating table 0.8 meters above the ground at a semi-anechoic chamber. The table was rotated 360 degrees to determine the position of the highest radiation.
- (2). The EUT was set 3 meters away from the interference-receiving antenna, which was mounted on the top of a variable-height antenna tower.
- (3).The antenna is a broadband antenna, and its height is varied from 1 to 4 meter above the ground to determine the maximum value of the field strength. Both horizontal and vertical polarizations of the antenna are set to make the measurement.
- (4). For each suspected emission, the EUT was arranged to its worst case and then the antenna was tuned to the heights from 1 to 4 meters and the rotatable table was turned from 0 degrees to 360 degrees to find the maximum reading.

### 7.3. BLOCK DIAGRAM OF TEST SETUP

#### Radiated Disturbance below 1 GHz

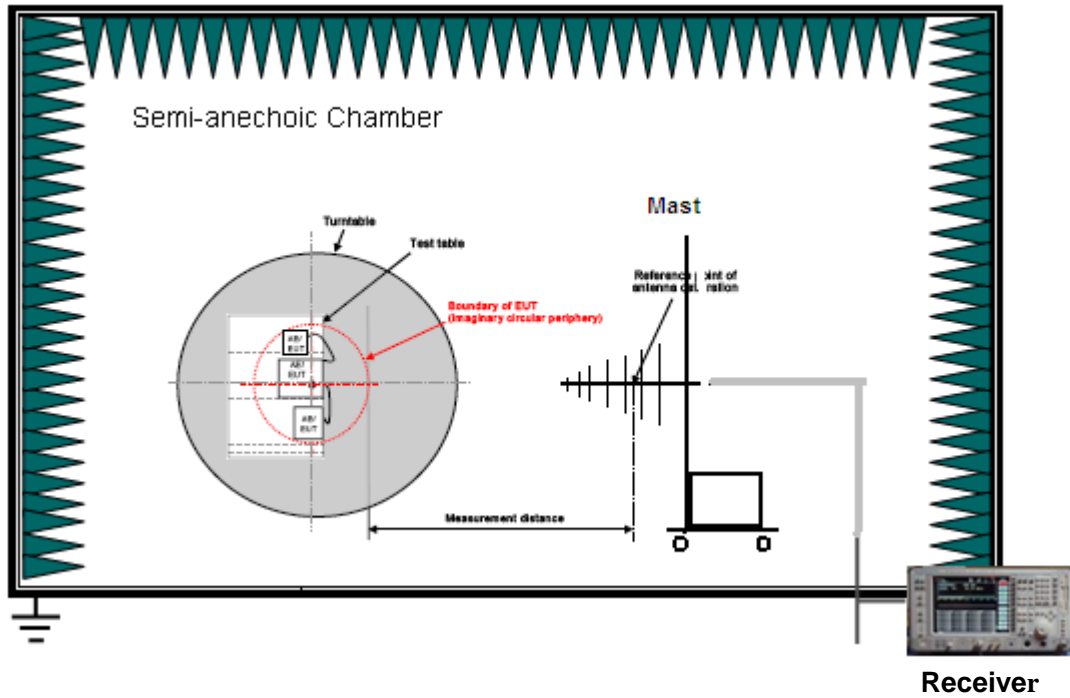

#### Radiated Disturbance above 1 GHz

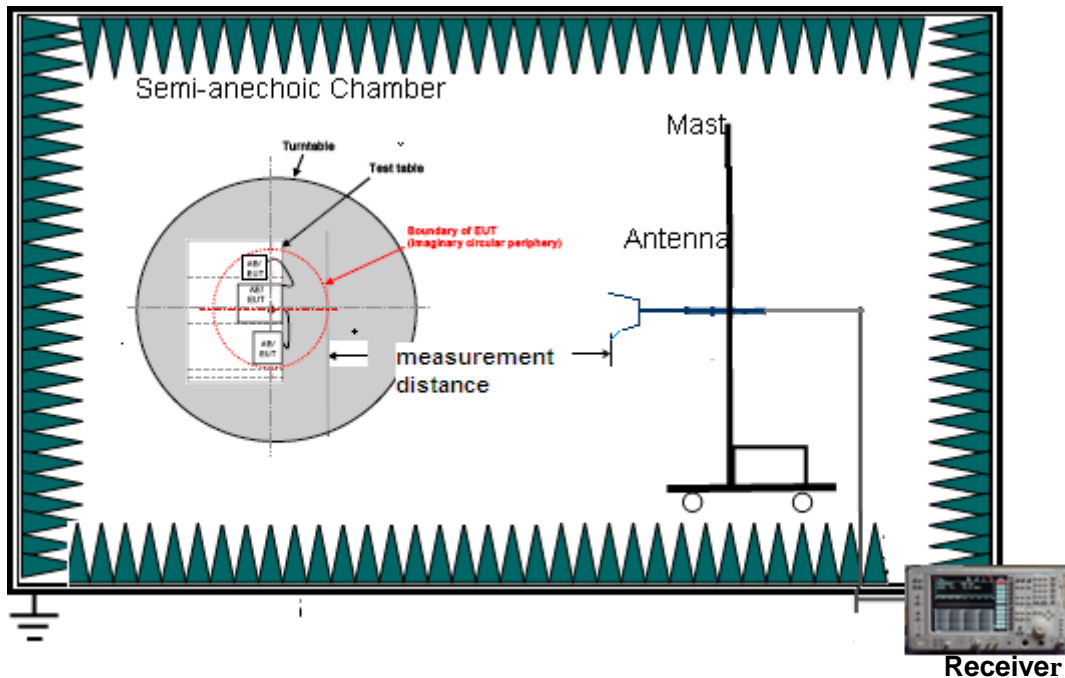

For the actual test configuration, please refer to the related item-Photographs of the Test Configuration.

Any report having not been signed by authorized approver, or having been altered without authorization, or having not been stamped by the “Dedicated Testing/Inspection Stamp” is deemed to be invalid. Copying or excerpting portion of, or altering the content of the report is not permitted without the written authorization of AGC. The test results presented in the report apply only to the tested sample. Any objections to report issued by AGC should be submitted to AGC within 15days after the issuance of the test report. Further enquiry of validity or verification of the test report should be addressed to AGC by agc01@agccert.com.

### 7.4. TEST RESULT

The test modes were carried out for all modes.

The worst test mode of the EUT was Mode 1, and its test data was showed as the follow:

#### RADIATED EMISSION BELOW 1GHz– HORIZONTAL

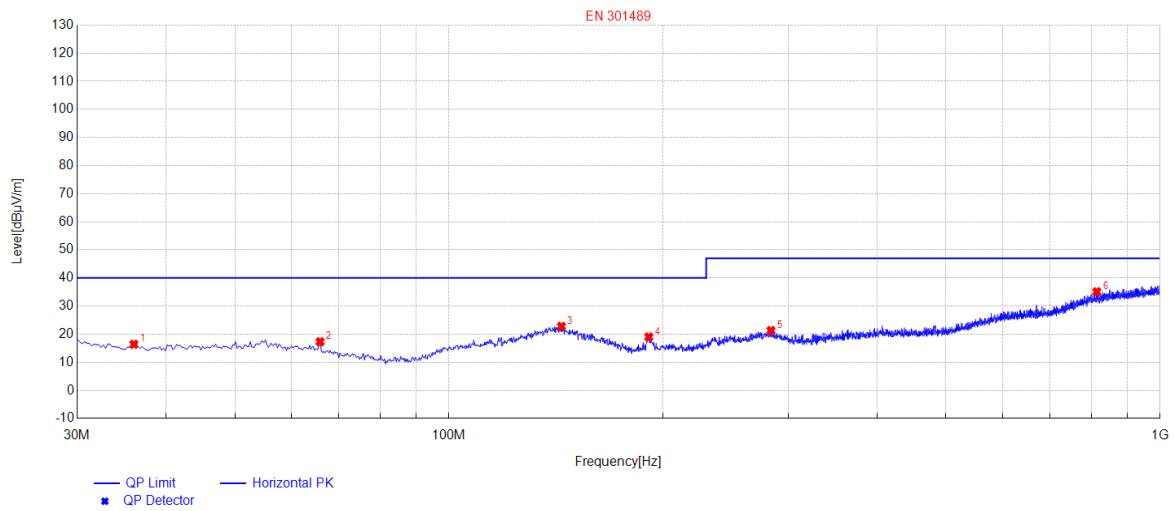

NO.	Freq. [MHz]	Level [dBµV/m]	Factor [dB]	Limit [dBµV/m]	Margin [dB]	Height [cm]	Angle [°]	Polarity
1	36.0625	16.40	10.73	40.00	23.60	100	265	Horizontal
2	65.89	17.30	9.93	40.00	22.70	100	342	Horizontal
3	143.975	22.78	17.29	40.00	17.22	100	50	Horizontal
4	191.02	19.02	11.58	40.00	20.98	100	271	Horizontal
5	283.655	21.31	16.04	47.00	25.69	100	206	Horizontal
6	814.73	35.10	29.41	47.00	11.90	100	122	Horizontal

**RESULT: PASS**

Any report having not been signed by authorized approver, or having been altered without authorization, or having not been stamped by the “Dedicated Testing/Inspection Stamp” is deemed to be invalid. Copying or excerpting portion of, or altering the content of the report is not permitted without the written authorization of AGC. The test results presented in the report apply only to the tested sample. Any objections to report issued by AGC should be submitted to AGC within 15days after the issuance of the test report. Further enquiry of validity or verification of the test report should be addressed to AGC by agc01@agccert.com.



### RADIATED EMISSION BELOW 1GHz- VERTICAL

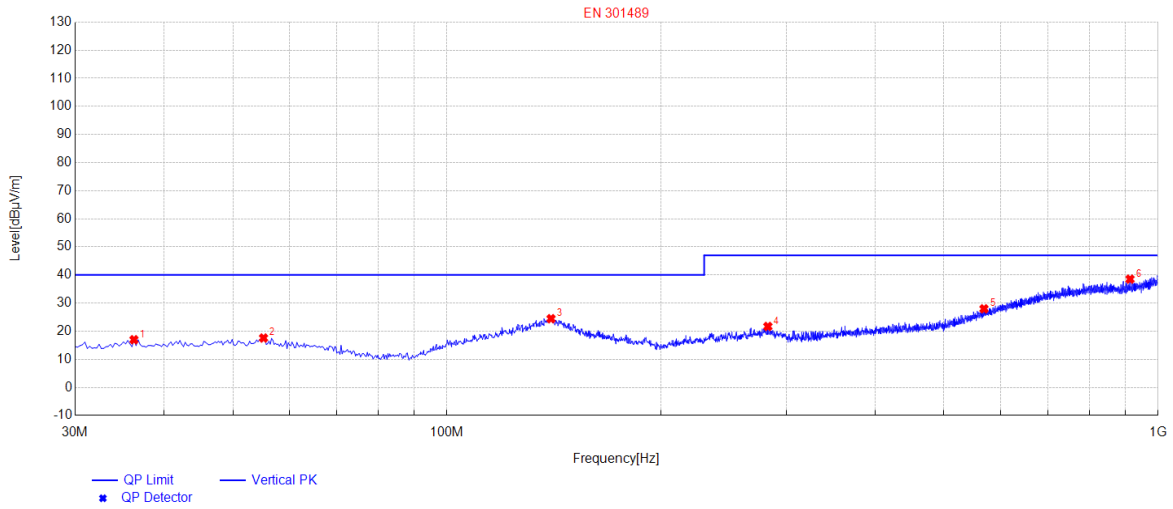

NO.	Freq. [MHz]	Level [dBµV/m]	Factor [dB]	Limit [dBµV/m]	Margin [dB]	Height [cm]	Angle [°]	Polarity
1	36.305	16.96	10.73	40.00	23.04	100	171	Vertical
2	55.22	17.57	11.27	40.00	22.43	100	17	Vertical
3	140.095	24.43	19.86	40.00	15.57	100	356	Vertical
4	282.685	21.68	16.10	47.00	25.32	100	22	Vertical
5	569.0775	27.95	22.92	47.00	19.05	100	289	Vertical
6	913.185	38.52	31.91	47.00	8.48	100	70	Vertical

**RESULT: PASS**

Any report having not been signed by authorized approver, or having been altered without authorization, or having not been stamped by the "Dedicated Testing/Inspection Stamp" is deemed to be invalid. Copying or excerpting portion of, or altering the content of the report is not permitted without the written authorization of AGC. The test results presented in the report apply only to the tested sample. Any objections to report issued by AGC should be submitted to AGC within 15days after the issuance of the test report. Further enquiry of validity or verification of the test report should be addressed to AGC by agc01@agccert.com.

### RADIATED EMISSION ABOVE 1GHz – HORIZONTAL

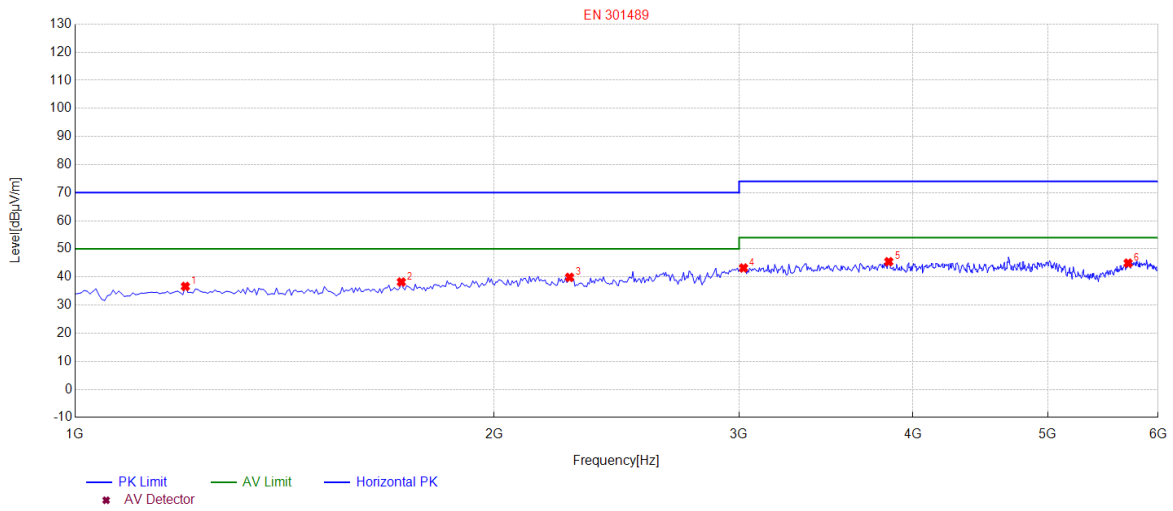

NO.	Freq. [MHz]	Level [dBµV/m]	Factor [dB]	Limit [dBµV/m]	Margin [dB]	Height [cm]	Angle [°]	Polarity
1	1200.2002	36.63	-19.88	70.00	33.37	100	280	Horizontal
2	1715.7157	38.20	-18.24	70.00	31.80	100	280	Horizontal
3	2266.2663	39.86	-14.48	70.00	30.14	100	190	Horizontal
4	3022.022	43.19	-11.16	74.00	30.81	100	330	Horizontal
5	3842.8428	45.44	-8.60	74.00	28.56	100	330	Horizontal
6	5709.7097	44.92	-5.88	74.00	29.08	100	320	Horizontal

**RESULT: PASS**

Any report having not been signed by authorized approver, or having been altered without authorization, or having not been stamped by the “Dedicated Testing/Inspection Stamp” is deemed to be invalid. Copying or excerpting portion of, or altering the content of the report is not permitted without the written authorization of AGC. The test results presented in the report apply only to the tested sample. Any objections to report issued by AGC should be submitted to AGC within 15days after the issuance of the test report. Further enquiry of validity or verification of the test report should be addressed to AGC by agc01@agccert.com.

Attestation of Global Compliance(Shenzhen)Co., Ltd  
Attestation of Global Compliance(Shenzhen)Std & Tech Co., Ltd  
Tel: +86-755 2523 4088 E-mail: agc@agccert.com Web: http://www.agccert.com/

### RADIATED EMISSION ABOVE 1GHz - VERTICAL

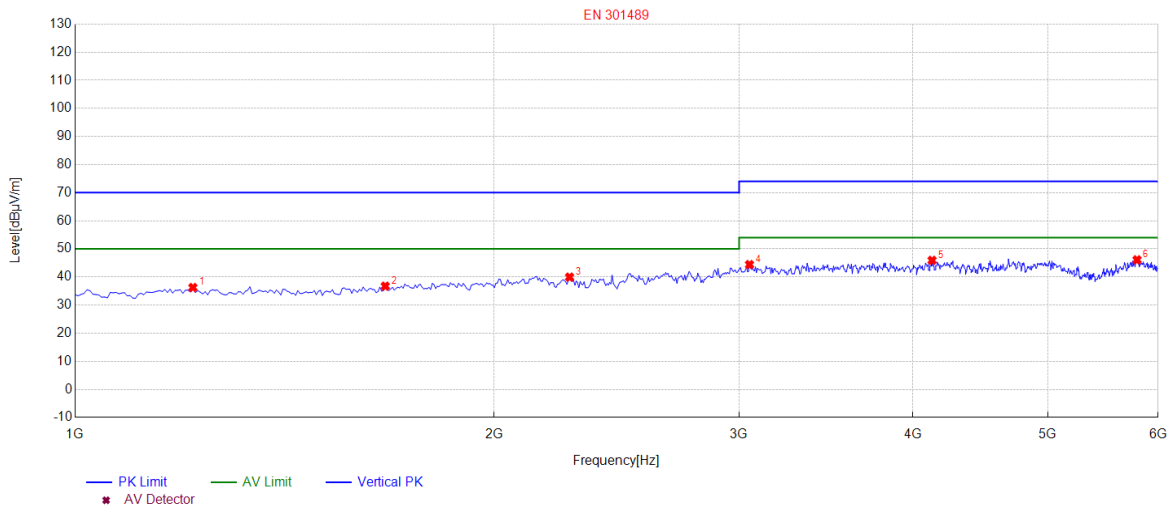

NO.	Freq. [MHz]	Level [dBµV/m]	Factor [dB]	Limit [dBµV/m]	Margin [dB]	Height [cm]	Angle [°]	Polarity
1	1215.2152	36.25	-19.88	70.00	33.75	100	290	Vertical
2	1670.6707	36.73	-18.60	70.00	33.27	100	200	Vertical
3	2266.2663	39.94	-14.48	70.00	30.06	100	300	Vertical
4	3052.0521	44.40	-11.07	74.00	29.60	100	330	Vertical
5	4128.1281	45.91	-7.95	74.00	28.09	100	50	Vertical
6	5794.7948	46.09	-5.59	74.00	27.91	100	200	Vertical

**RESULT: PASS**

Any report having not been signed by authorized approver, or having been altered without authorization, or having not been stamped by the “Dedicated Testing/Inspection Stamp” is deemed to be invalid. Copying or excerpting portion of, or altering the content of the report is not permitted without the written authorization of AGC. The test results presented in the report apply only to the tested sample. Any objections to report issued by AGC should be submitted to AGC within 15days after the issuance of the test report. Further enquiry of validity or verification of the test report should be addressed to AGC by agc01@agccert.com.

## 8. MAINS TERMINAL DISTURBANCE VOLTAGE MEASUREMENT

### 8.1. LIMITS OF MAINS TERMINAL DISTURBANCE VOLTAGE

Frequency range (MHz)	Limits (dBuV) Class B ITE	
	Quasi-peak	Average
0.15 - 0.50	66 to 56	56 to 46
0.50 - 5	56	46
5 - 30	60	50

- Note: 1. The lower limit shall apply at the transition frequencies.  
2. The limit decreases linearly with the logarithm of the frequency in the range 0.15MHz to 0.50MHz.

### 8.2. TEST PROCEDURE

- (1) The EUT was placed 0.4 meters from the conducting wall of shielded room with EUT being connected to the power mains through a line impedance stabilization network (LISN). The LISN provide 50Ω/50μH of coupling impedance for the measuring instrument.
- (2) Both lines of the power mains connected to the EUT were checked for maximum conducted interference.
- (3)The frequency range from 150 kHz to 30 MHz was searched. Emission levels over 20dB under the prescribed limits are not reported.

### 8.3. TEST SETUP

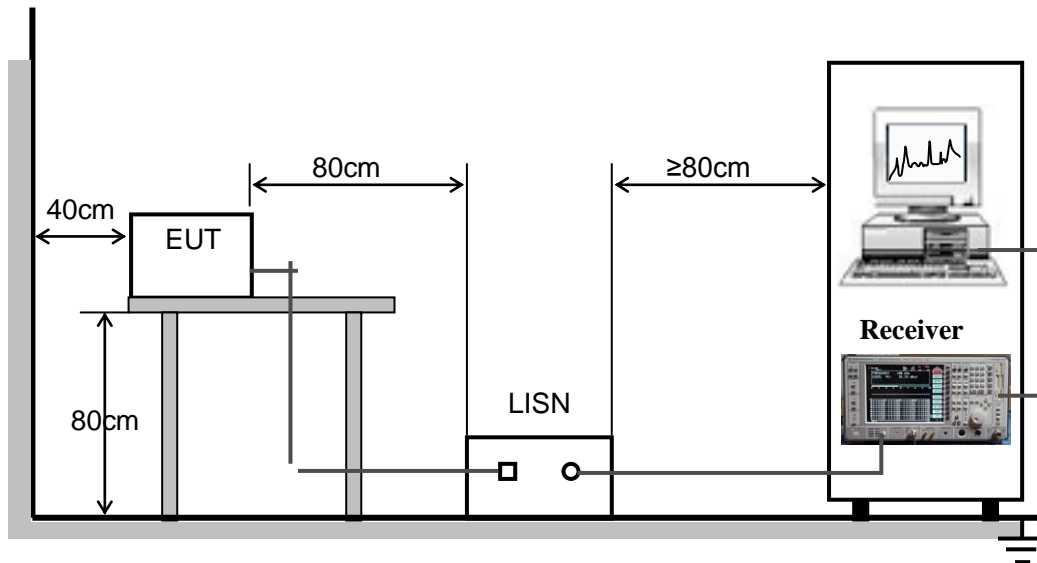

For the actual test configuration, please refer to the related item - Photographs of the Test Configuration.

### 8.4. TEST RESULT

The test modes were carried out for all modes.

Any report having not been signed by authorized approver, or having been altered without authorization, or having not been stamped by the "Dedicated Testing/Inspection Stamp" is deemed to be invalid. Copying or excerpting portion of, or altering the content of the report is not permitted without the written authorization of AGC. The test results presented in the report apply only to the tested sample. Any objections to report issued by AGC should be submitted to AGC within 15days after the issuance of the test report. Further enquiry of validity or verification of the test report should be addressed to AGC by [agc01@agccert.com](mailto:agc01@agccert.com).

LINE CONDUCTED EMISSION TEST-L

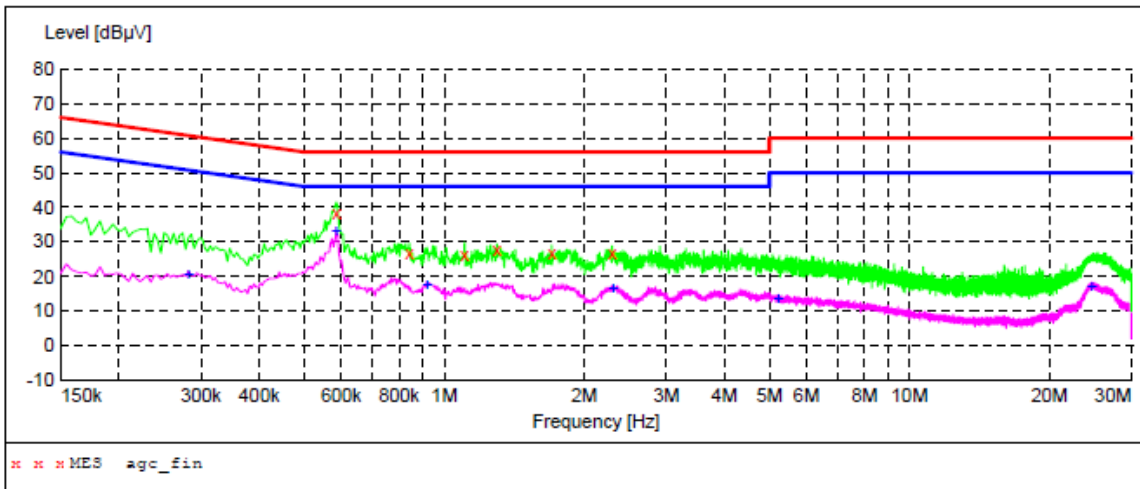

**MEASUREMENT RESULT: "agc\_fin"**

2022/7/26 22:44

Frequency MHz	Level dBµV	Transd dB	Limit dBµV	Margin dB	Detector	Line
0.586000	38.40	5.4	56	17.6	QP	L1
0.842000	26.50	5.4	56	29.5	QP	L1
1.106000	26.20	5.6	56	29.8	QP	L1
1.298000	27.60	5.8	56	28.4	QP	L1
1.702000	26.60	6.2	56	29.4	QP	L1
2.294000	26.90	6.5	56	29.1	QP	L1

**MEASUREMENT RESULT: "agc\_fin2"**

2022/7/26 22:43

Frequency MHz	Level dBµV	Transd dB	Limit dBµV	Margin dB	Detector	Line
0.282000	20.70	6.1	51	30.1	AV	L1
0.586000	33.30	5.4	46	12.7	AV	L1
0.918000	17.60	5.4	46	28.4	AV	L1
2.306000	16.70	6.5	46	29.3	AV	L1
5.226000	13.70	6.6	50	36.3	AV	L1
24.638000	17.40	9.1	50	32.6	AV	L1

**RESULT: PASS**

Any report having not been signed by authorized approver, or having been altered without authorization, or having not been stamped by the "Dedicated Testing/Inspection Stamp" is deemed to be invalid. Copying or excerpting portion of, or altering the content of the report is not permitted without the written authorization of AGC. The test results presented in the report apply only to the tested sample. Any objections to report issued by AGC should be submitted to AGC within 15days after the issuance of the test report. Further enquiry of validity or verification of the test report should be addressed to AGC by agc01@agccert.com.

LINE CONDUCTED EMISSION TEST-N

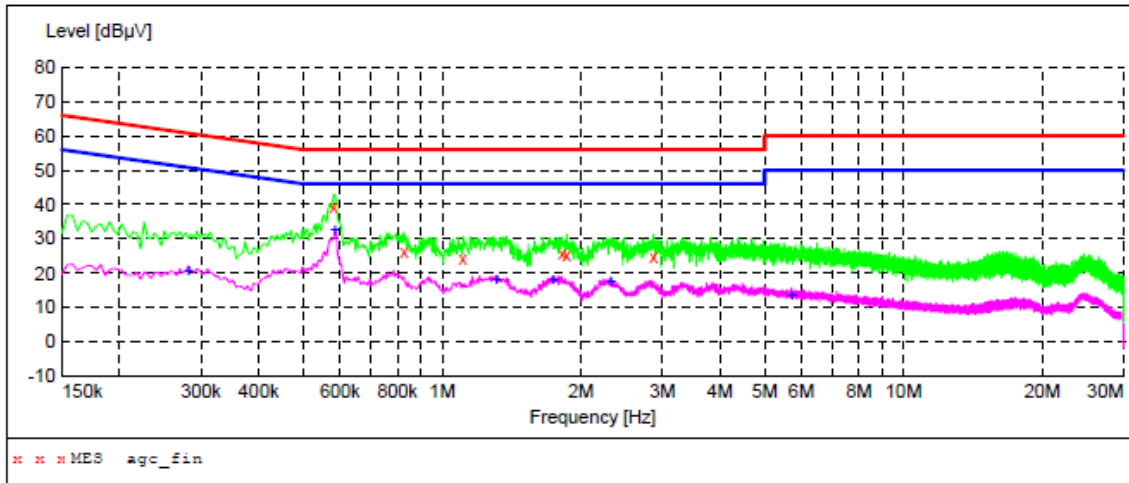

**MEASUREMENT RESULT: "agc\_fin"**

2022/7/26 22:47

Frequency MHz	Level dBµV	Transd dB	Limit dBµV	Margin dB	Detector	Line
0.582000	39.30	5.4	56	16.7	QP	N
0.826000	26.20	5.4	56	29.8	QP	N
1.110000	24.20	5.6	56	31.8	QP	N
1.818000	25.70	6.3	56	30.3	QP	N
1.862000	25.30	6.4	56	30.7	QP	N
2.870000	24.90	6.5	56	31.1	QP	N

**MEASUREMENT RESULT: "agc\_fin2"**

2022/7/26 22:47

Frequency MHz	Level dBµV	Transd dB	Limit dBµV	Margin dB	Detector	Line
0.282000	20.80	6.1	51	30.0	AV	N
0.586000	32.70	5.4	46	13.3	AV	N
1.310000	18.30	5.8	46	27.7	AV	N
1.738000	18.10	6.3	46	27.9	AV	N
2.322000	17.60	6.5	46	28.4	AV	N
5.718000	13.80	6.6	50	36.2	AV	N

**RESULT: PASS**

Any report having not been signed by authorized approver, or having been altered without authorization, or having not been stamped by the "Dedicated Testing/Inspection Stamp" is deemed to be invalid. Copying or excerpting portion of, or altering the content of the report is not permitted without the written authorization of AGC. The test results presented in the report apply only to the tested sample. Any objections to report issued by AGC should be submitted to AGC within 15days after the issuance of the test report. Further enquiry of validity or verification of the test report should be addressed to AGC by agc01@agccert.com.

## 9. HARMONIC CURRENT MEASUREMENT

### 9.1. LIMITS OF HARMONIC CURRENT

Limits for Class A Equipment	
Harmonics Order n	Max. permissible harmonic current (A)
<b>Odd harmonics</b>	
3	2.30
5	1.14
7	0.77
9	0.40
11	0.33
13	0.21
15≤n≤39	0.15×15/n
<b>Even harmonics</b>	
2	1.08
4	0.43
6	0.30
8≤n≤40	0.23×8/n

Note: 1. According to section 5 of EN61000-3-2: 2014, the EUT is Class A equipment.

2. The above limits are for all applications having an active input power >75W. No limits apply for equipment with an active input power up to and including 75W.

### 9.2. TEST PROCEDURE

1. The EUT was placed on the top of a wooden table 0.8 meters above the ground and operated to produce the maximum harmonic components under normal operating conditions for each successive harmonic component in turn.
2. The correspondent test program of test instrument to measure the current harmonics emanated from EUT is chosen. The measure time shall be not less than the necessary for the EUT to be exercised.



### 9.3. TEST SETUP

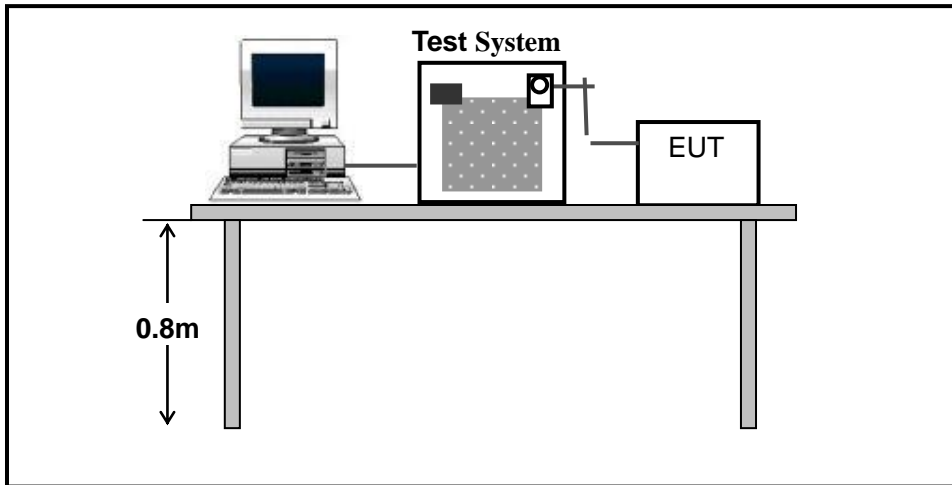

For the actual test configuration, please refer to Appendix I: Photographs of the Test Configuration.

### 9.4. TEST RESULT

No applicable for equipment with an active input power up to and including 75W.

Any report having not been signed by authorized approver, or having been altered without authorization, or having not been stamped by the "Dedicated Testing/Inspection Stamp" is deemed to be invalid. Copying or excerpting portion of, or altering the content of the report is not permitted without the written authorization of AGC. The test results presented in the report apply only to the tested sample. Any objections to report issued by AGC should be submitted to AGC within 15days after the issuance of the test report. Further enquiry of validity or verification of the test report should be addressed to AGC by [agc01@agccert.com](mailto:agc01@agccert.com).

Attestation of Global Compliance(Shenzhen)Co., Ltd  
Attestation of Global Compliance(Shenzhen)Std & Tech Co., Ltd  
Tel: +86-755 2523 4088 E-mail: [agc@agccert.com](mailto:agc@agccert.com) Web: <http://www.agccert.com/>

## 10. VOLTAGE FLUCTUATIONS AND FLICK MEASUREMENT

### 10.1. LIMITS OF VOLTAGE FLUCTUATIONS AND FLICK

Test Item	Limit	Note
$P_{st}$	1.0	$P_{st}$ means Short-term flicker indicator
$P_{lt}$	0.65	$P_{lt}$ means long-term flicker indicator
$T_{dt}$	0.5	$T_{dt}$ means maximum time that $d_t$ exceeds 3.3%
$d_{max}(\%)$	4%	$d_{max}$ means maximum relative voltage change.
$d_c(\%)$	3.3%	$d_c$ means relative steady-state voltage change.

### 10.2. TEST PROCEDURE

1. The EUT was placed on the top of a wooden table 0.8 meters above the ground and operated to produce the most unfavorable sequence of voltage changes under normal conditions
2. During the flick measurement, the measure time shall include that part of whole operation changes. The observation period for short-term flicker indicator is 10 minutes and the observation period for long-term flicker indicator is 2 hours.

### 10.3. TEST SETUP

Same as 9.3

### 10.4. TEST RESULT

#### Test Specification

<b>Test Frequency</b>	50Hz	<b>Test Voltage</b>	230V AC
<b>Waveform</b>	Sine	<b>Test Time</b>	10 minutes( $P_{st}$ ); 2 hours ( $P_{lt}$ )

#### Test Result

Test Parameter	Measurement Value	Limit	Remarks
$P_{st}$	0.160	1.0	Pass
$P_{lt}$	0.070	0.65	Pass
$T_{dt(s)}$	0.0	0.5	Pass
$d_{max}(\%)$	0.00%	4%	Pass
$d_c(\%)$	0.00%	3.3%	Pass

Any report having not been signed by authorized approver, or having been altered without authorization, or having not been stamped by the "Dedicated Testing/Inspection Stamp" is deemed to be invalid. Copying or excerpting portion of, or altering the content of the report is not permitted without the written authorization of AGC. The test results presented in the report apply only to the tested sample. Any objections to report issued by AGC should be submitted to AGC within 15days after the issuance of the test report. Further enquiry of validity or verification of the test report should be addressed to AGC by [agc01@agccert.com](mailto:agc01@agccert.com).

## 11. IMMUNITY TEST

### 11.1. DESCRIPTION OF PERFORMANCE CRITERIA

The performance criteria are used to take a decision on whether a radio equipment passes or fails immunity tests.

For the purpose of the present document two categories of performance criteria apply:

- Performance criteria for continuous phenomena.
- Performance criteria for transient phenomena.

### 11.2. GENERAL PERFORMANCE CRITERIA

#### 1. Performance criteria for continuous phenomena

During the test, the equipment shall:

- continue to operate as intended;
- not unintentionally transmit;
- not unintentionally change its operating state;
- not unintentionally change critical stored data.

#### 2. Performance criteria for transient phenomena

For all ports and transient phenomena with the exception described below, the following applies:

- The application of the transient phenomena shall not result in a change of the mode of operation (e.g. unintended transmission) or the loss of critical stored data.
- After application of the transient phenomena, the equipment shall operate as intended.

For surges applied to symmetrically operated wired network ports intended to be connected directly to outdoor lines the following criteria applies:

- For products with only one symmetrical port intended for connection to outdoor lines, loss of function is allowed, provided the function is self-recoverable, or can be otherwise restored. Information stored in non-volatile memory, or protected by a battery backup, shall not be lost.
- For products with more than one symmetrical port intended for connection to outdoor lines, loss of function on the port under test is allowed, provided the function is self-recoverable. Information stored in non-volatile memory, or protected by a battery backup, shall not be lost.

For a 0 % residual voltage dip tests the following performance criteria apply:

- The performance criteria for transient phenomena shall apply.

For a 70 % residual voltage dip and voltage interruption tests, the following performance criteria apply:

- in the case where the equipment is fitted with or connected to a battery back-up, the performance criteria for transient phenomena shall apply;
- in the case where the equipment is powered solely from the AC mains supply (without the use of a parallel battery back-up) volatile user data may have been lost and if applicable the communication link need not to be maintained and lost functions should be recoverable by user or operator;
- no unintentional responses shall occur at the end of the test, when the voltage is restored to nominal;
- in the event of loss of function(s) or in the event of loss of user stored data, this fact shall be recorded.

Any report having not been signed by authorized approver, or having been altered without authorization, or having not been stamped by the "Dedicated Testing/Inspection Stamp" is deemed to be invalid. Copying or excerpting portion of, or altering the content of the report is not permitted without the written authorization of AGC. The test results presented in the report apply only to the tested sample. Any objections to report issued by AGC should be submitted to AGC within 15days after the issuance of the test report. Further enquiry of validity or verification of the test report should be addressed to AGC by [agc01@agccert.com](mailto:agc01@agccert.com).

### 5. Performance Table

EN 301 489-17 Performance criteria		
Criteria	During Test	After Test (i.e. as a result of the application of the test)
A	Shall operate as intended. (see note). Shall be no loss of function. Shall be no unintentional transmissions.	Shall operate as intended. Shall be no degradation of performance. Shall be no loss of function. Shall be no loss of critical stored data.
B	May be loss of function.	Functions shall be self-recoverable. Shall operate as intended after recovering. Shall be no loss of critical stored data.
C	May be loss of function.	Functions shall be recoverable by the operator. Shall operate as intended after recovering. Shall be no loss of critical stored data.
<p>The performance criteria A shall apply for continuous phenomena. The performance criteria B shall apply for transient phenomena, except for voltage dips greater than or equal to 100 ms and voltage interruptions of 5 000 ms duration, for which performance criteria C shall apply. Where the EUT is a transmitter in standby mode or receive mode, unintentional transmission shall not occur during the test.</p>		
<p>Note: Operate as intended during the test allows a level of degradation in accordance with the Minimum performance level.</p>		
<b>Minimum performance level</b>		
<p>For equipment that supports a PER or FER, the minimum performance level shall be a PER or FER less than or equal to 10 %. For equipment that does not support a PER or a FER, the minimum performance level shall be no loss of the wireless transmission function needed for the intended use of the equipment.</p>		

Any report having not been signed by authorized approver, or having been altered without authorization, or having not been stamped by the "Dedicated Testing/Inspection Stamp" is deemed to be invalid. Copying or excerpting portion of, or altering the content of the report is not permitted without the written authorization of AGC. The test results presented in the report apply only to the tested sample. Any objections to report issued by AGC should be submitted to AGC within 15days after the issuance of the test report. Further enquiry of validity or verification of the test report should be addressed to AGC by agc01@agccert.com.

## 12. ELECTROSTATIC DISCHARGE IMMUNITY TEST

### 12.1 TEST SPECIFICATION

<b>Basic Standard</b>	EN 61000-4-2
<b>Discharge Impedance</b>	330Ω / 150 pF
<b>Discharge Voltage</b>	Air Discharge –8 kV, Contact Discharge – 4 kV
<b>Polarity</b>	Positive / Negative
<b>Number of Discharge</b>	Minimum 20 times at each test point
<b>Discharge Mode</b>	Single discharge
<b>Discharge Period</b>	1-second minimum

### 12.2 TEST PROCEDURE

The test procedure was in accordance with EN 61000-4-2:

- a. Electrostatic discharges were applied only to those points and surfaces of the EUT that are accessible to users during normal operation.
- b. The test was performed with at least ten single discharges on the pre-selected points in the most sensitive polarity.
- c. The time interval between two successive single discharges was at least 1 second.
- d. The ESD generator was held perpendicularly to the surface to which the discharge was applied and the return cable was at least 0.2 meters from the EUT.
- e. Contact discharges were applied to the non-insulating coating, with the pointed tip of the generator penetrating the coating and contacting the conducting substrate.
- f. Air discharges were applied with the round discharge tip of the discharge electrode approaching the EUT as fast as possible (without causing mechanical damage) to touch the EUT. After each discharge, the ESD generator was removed from the EUT and re-triggered for a new single discharge. The test was repeated until all discharges were completed.
- g. At least ten single discharges (in the most sensitive polarity) were applied to the Horizontal Coupling Plane at points on each side of the EUT. The ESD generator was positioned vertically at a distance of 0.1 meters from the EUT with the discharge electrode touching the HCP.
- h. At least ten single discharges (in the most sensitive polarity) were applied to the center of one vertical edge of the Vertical Coupling Plane in sufficiently different positions that the four faces of the EUT were completely illuminated. The VCP (dimensions 0.5m x 0.5m) was placed vertically to and 0.1 meters from the EUT.

Any report having not been signed by authorized approver, or having been altered without authorization, or having not been stamped by the "Dedicated Testing/Inspection Stamp" is deemed to be invalid. Copying or excerpting portion of, or altering the content of the report is not permitted without the written authorization of AGC. The test results presented in the report apply only to the tested sample. Any objections to report issued by AGC should be submitted to AGC within 15 days after the issuance of the test report. Further enquiry of validity or verification of the test report should be addressed to AGC by [agc01@agccert.com](mailto:agc01@agccert.com).

### 12.3 TEST SETUP

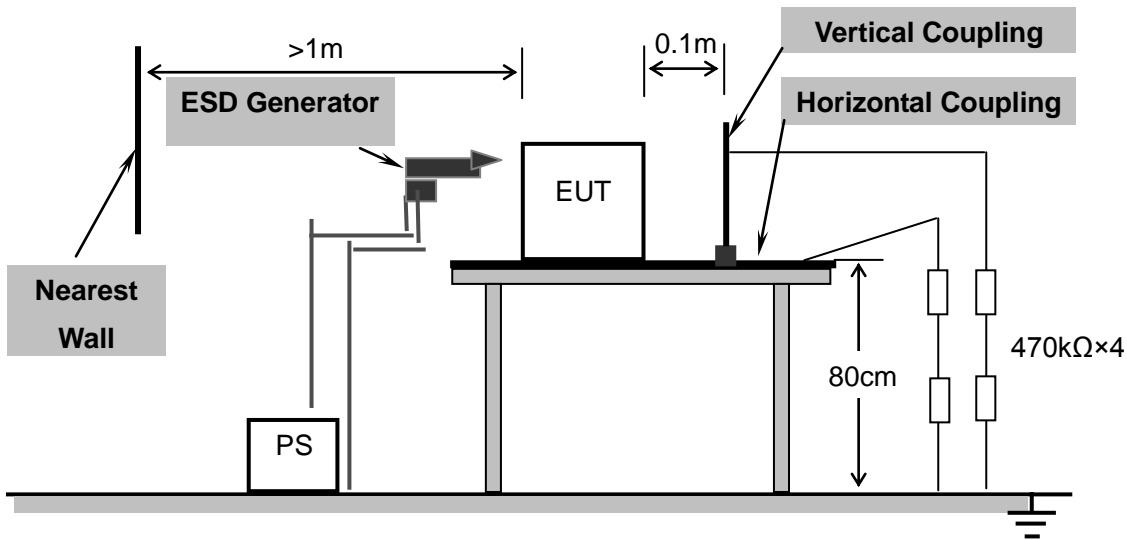

For the actual test configuration, please refer to Appendix A: Photographs of the Test Configuration.

### 12.4 TEST RESULT

#### DESCRIPTION OF THE ELECTROSTATIC DISCHARGES (ESD)

Times of Discharge	Voltage	Coupling	Test Mode	Performance criteria
Mini 25 / Point	±2kV; ±4kV	Contact discharge	Mode 1/2	A
Mini 25 / Point	±2kV; ±4kV; ±8kV	Air Discharge	Mode 1/2	A
Mini 25 / Point	±4kV	Indirect Discharge HCP	Mode 1/2	A
Mini 25 / Point	±4kV	Indirect Discharge VCP	Mode 1/2	A

A: No degradation in the performance of the EUT was observed.

Any report having not been signed by authorized approver, or having been altered without authorization, or having not been stamped by the "Dedicated Testing/Inspection Stamp" is deemed to be invalid. Copying or excerpting portion of, or altering the content of the report is not permitted without the written authorization of AGC. The test results presented in the report apply only to the tested sample. Any objections to report issued by AGC should be submitted to AGC within 15days after the issuance of the test report. Further enquiry of validity or verification of the test report should be addressed to AGC by agc01@agccert.com.

ESD location:

Blue line: Air discharge

Red line: Contact discharge



Any report having not been signed by authorized approver, or having been altered without authorization, or having not been stamped by the "Dedicated Testing/Inspection Stamp" is deemed to be invalid. Copying or excerpting portion of, or altering the content of the report is not permitted without the written authorization of AGC. The test results presented in the report apply only to the tested sample. Any objections to report issued by AGC should be submitted to AGC within 15days after the issuance of the test report. Further enquiry of validity or verification of the test report should be addressed to AGC by [agc01@agccert.com](mailto:agc01@agccert.com).

Attestation of Global Compliance(Shenzhen)Co., Ltd

Attestation of Global Compliance(Shenzhen)Std & Tech Co., Ltd

Tel: +86-755 2523 4088 E-mail: [agc@agccert.com](mailto:agc@agccert.com) Web: <http://www.agccert.com/>

**12.5 PERFORMANCE**

<input checked="" type="checkbox"/> <b>Criteria A:</b>	The apparatus continues to operate as intended. No degradation of performance or loss of function is allowed below a performance level specified by the manufacturer, when the apparatus is used as intended. In some cases the performance level may be replaced by a permissible loss of performance.
<input type="checkbox"/> <b>Criteria B:</b>	The apparatus continues to operate as intended after the test. No degradation of performance or loss of function is allowed below a performance level specified by the manufacturer, when the apparatus is used as intended. In some cases the performance level may be replaced by a permissible loss of performance. During the test, degradation of performance is however allowed.
<input type="checkbox"/> <b>Criteria C:</b>	Temporary loss of function is allowed, provided the functions self recoverable or can be restored by the operation of controls.

**PASS**
                 
  **FAIL**

Any report having not been signed by authorized approver, or having been altered without authorization, or having not been stamped by the "Dedicated Testing/Inspection Stamp" is deemed to be invalid. Copying or excerpting portion of, or altering the content of the report is not permitted without the written authorization of AGC. The test results presented in the report apply only to the tested sample. Any objections to report issued by AGC should be submitted to AGC within 15days after the issuance of the test report. Further enquiry of validity or verification of the test report should be addressed to AGC by agc01@agccert.com.



### 13. RADIATED, RADIO FREQUENCY ELECTROMAGNETIC FIELD IMMUNITY TEST

#### 13.1. TEST SPECIFICATION

<b>Basic Standard</b>	EN 61000-4-3
<b>Frequency Range</b>	80 MHz – 6000MHz
<b>Field Strength</b>	3V/m
<b>Modulation</b>	1 kHz sine wave, 80%, AM modulation
<b>Frequency Step</b>	1% of fundamental
<b>Polarity of Antenna</b>	Horizontal and Vertical
<b>Test Distance</b>	3m
<b>Antenna Height</b>	1.55m
<b>Dwell Time</b>	3 seconds

#### 13.2. TEST PROCEDURE

The test procedure was in accordance with EN 61000-4-3.

- a. The testing was performed in a fully anechoic chamber. The transmit antenna was located at a distance of 3 meters from the EUT.
- b. The test signal was 80% amplitude modulated with a 1 kHz sine wave.
- c. The frequency range was swept from 80 MHz to 6000MHz with the exception of the exclusion band for transmitters, receivers and duplex transceivers. The rate of sweep did not exceed  $1.5 \times 10^{-3}$  decade/s. Where the frequency range is swept incrementally, the step size was 1% of fundamental.
- d. The dwell time at each frequency shall be not less than the time necessary for the EUT to be able to respond.
- e. The field strength level was 3V/m.
- f. The test was performed with the EUT exposed to both vertically and horizontally polarized fields on each of the four sides.

### 13.3. TEST SETUP

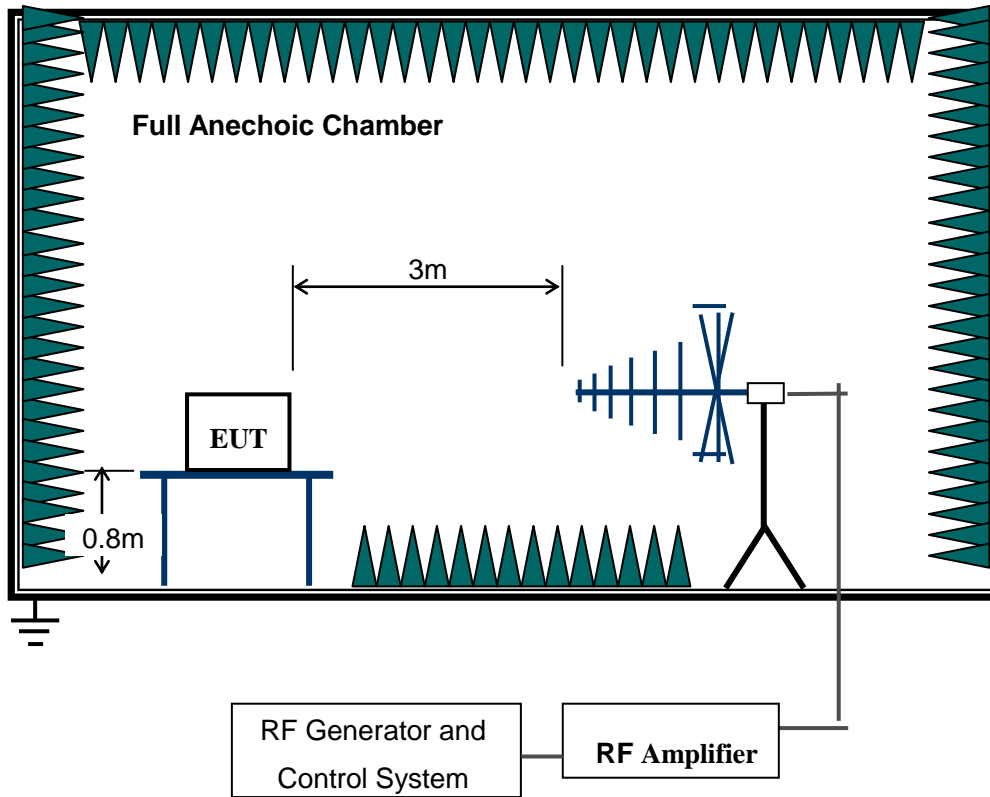

For the actual test configuration, please refer to Appendix A: Photographs of the Test Configuration.

Any report having not been signed by authorized approver, or having been altered without authorization, or having not been stamped by the “Dedicated Testing/Inspection Stamp” is deemed to be invalid. Copying or excerpting portion of, or altering the content of the report is not permitted without the written authorization of AGC. The test results presented in the report apply only to the tested sample. Any objections to report issued by AGC should be submitted to AGC within 15days after the issuance of the test report. Further enquiry of validity or verification of the test report should be addressed to AGC by [agc01@agccert.com](mailto:agc01@agccert.com).

Attestation of Global Compliance(Shenzhen)Co., Ltd  
Attestation of Global Compliance(Shenzhen)Std & Tech Co., Ltd  
Tel: +86-755 2523 4088 E-mail: [agc@agccert.com](mailto:agc@agccert.com) Web: <http://www.agccert.com/>

### 13.4. TEST RESULT

Freq. Range (MHz)	Field	Modulation	Polarity	Position	Test Mode	Performance criteria
80-6000	3V/m	Yes	H	Front	Mode 1/2	A
80-6000	3V/m	Yes	H	Back	Mode 1/2	A
80-6000	3V/m	Yes	H	Left	Mode 1/2	A
80-6000	3V/m	Yes	H	Right	Mode 1/2	A
80-6000	3V/m	Yes	V	Front	Mode 1/2	A
80-6000	3V/m	Yes	V	Back	Mode 1/2	A
80-6000	3V/m	Yes	V	Left	Mode 1/2	A
80-6000	3V/m	Yes	V	Right	Mode 1/2	A

A: No degradation or PER < 10% in the performance of the EUT was observed.

### 13.5. PERFORMANCE

<input checked="" type="checkbox"/> <b>Criteria A:</b>	The apparatus continues to operate as intended. No degradation of performance or loss of function is allowed below a performance level specified by the manufacturer, when the apparatus is used as intended. In some cases the performance level may be replaced by a permissible loss of performance.
<input type="checkbox"/> <b>Criteria B:</b>	The apparatus continues to operate as intended after the test. No degradation of performance or loss of function is allowed below a performance level specified by the manufacturer, when the apparatus is used as intended. In some cases the performance level may be replaced by a permissible loss of performance. During the test, degradation of performance is however allowed.
<input type="checkbox"/> <b>Criteria C:</b>	Temporary loss of function is allowed, provided the functions self recoverable or can be restored by the operation of controls.

**PASS**

**FAIL**

## 14. ELECTRICAL FAST TRANSIENT/BURST IMMUNITY TEST

### 14.1. TEST SPECIFICATION

<b>Basic Standard</b>	EN 61000-4-4
<b>Test Voltage</b>	a.c. power port – 1 kV
<b>Polarity</b>	Positive/Negative
<b>Impulse Frequency</b>	5kHz
<b>Impulse wave shape</b>	5/50ns
<b>Burst Duration</b>	15ms
<b>Burst Period</b>	300ms
<b>Test Duration</b>	Not less than 1 min.

### 14.2. TEST PROCEDURE

1. The EUT was tested with 1000 volt discharges to the AC power input leads.
2. Both positive and negative polarity discharges were applied.
3. The length of the “hot wire” from the coaxial output of the EFT generator to the terminals on the EUT should not exceed 1 meter.
4. The duration time of each test sequential was 1 minute.
5. The transient/burst waveform was in accordance with IEC 61000-4-4, 5/50ns.

### 14.3. TEST SETUP

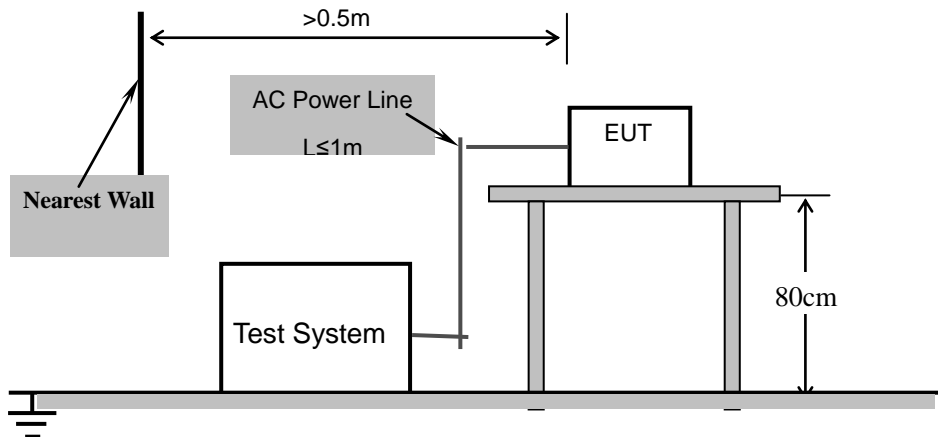

For the actual test configuration, please refer to Appendix A: Photographs of the Test Configuration.

#### 14.4. TEST RESULT

Test Point	Polarity	Test Level (kV)	Test Mode	Performance criteria
a.c. port, L	+/-	1	Mode 1	A
a.c. port, N	+/-	1	Mode 1	A
a.c. port, L-N	+/-	1	Mode 1	A

A: No degradation in the performance of the EUT was observed.

#### 14.5. PERFORMANCE

<input checked="" type="checkbox"/> <b>Criteria A:</b>	The apparatus continues to operate as intended. No degradation of performance or loss of function is allowed below a performance level specified by the manufacturer, when the apparatus is used as intended. In some cases the performance level may be replaced by a permissible loss of performance.
<input type="checkbox"/> <b>Criteria B:</b>	The apparatus continues to operate as intended after the test. No degradation of performance or loss of function is allowed below a performance level specified by the manufacturer, when the apparatus is used as intended. In some cases the performance level may be replaced by a permissible loss of performance. During the test, degradation of performance is however allowed.
<input type="checkbox"/> <b>Criteria C:</b>	Temporary loss of function is allowed, provided the functions self recoverable or can be restored by the operation of controls.

**PASS**
                 
  **FAIL**

Any report having not been signed by authorized approver, or having been altered without authorization, or having not been stamped by the "Dedicated Testing/Inspection Stamp" is deemed to be invalid. Copying or excerpting portion of, or altering the content of the report is not permitted without the written authorization of AGC. The test results presented in the report apply only to the tested sample. Any objections to report issued by AGC should be submitted to AGC within 15days after the issuance of the test report. Further enquiry of validity or verification of the test report should be addressed to AGC by agc01@agccert.com.

## 15. SURGE IMMUNITY TEST

### 15.1. TEST SPECIFICATION

<b>Basic Standard</b>	EN 61000-4-5
<b>Waveform</b>	Voltage 1.2/50 $\mu$ s; Current 8/20 $\mu$ s
<b>Test Voltage</b>	a.c. power port, line to line 1.0 kV
<b>Polarity</b>	Positive/Negative
<b>Phase Angle</b>	0°, 90°, 180°, 270°
<b>Repetition Rate</b>	60sec
<b>Times</b>	5 time/each condition.

### 15.2. TEST PROCEDURE

- The EUT and the auxiliary equipment were placed on a table of 0.8m heights above a metal ground reference plane. The size of ground plane is greater than 1m $\times$ 1m and project beyond the EUT by at least 0.1m on all sides. The ground plane is connected to the protective earth. The length of power cord between the coupling device and the EUT was less than 2 meters (provided by the manufacturer).
- The EUT was connected to the power mains through a coupling device that directly couples the surge interference signal. The surge noise was applied synchronized to the voltage phase at the zero crossing and the peak value of the AC voltage wave (positive and negative).
- The surges were applied line to line and line(s) to earth. All lower levels including the selected test level were tested. The polarity of each surge level included positive and negative test pulses.

### 15.3. TEST SETUP

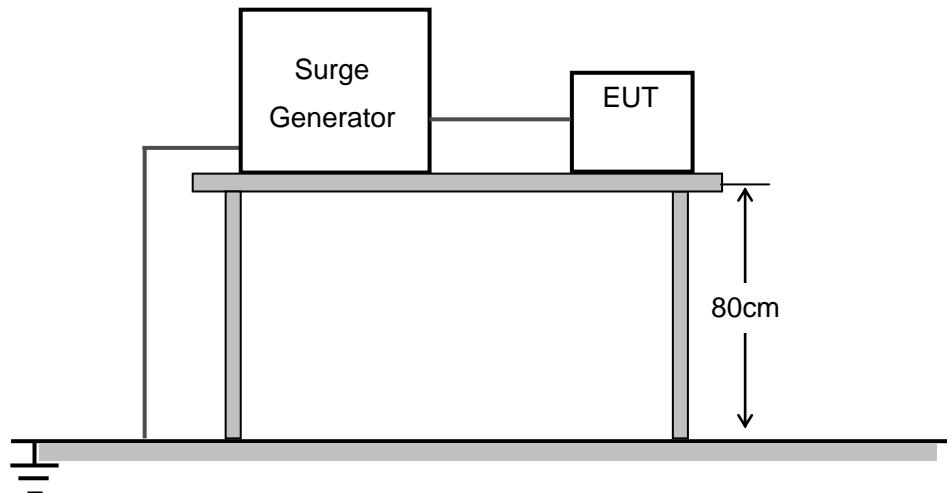

For the actual test configuration, please refer to Appendix A: Photographs of the Test Configuration.

#### 15.4. TEST RESULT

Coupling Line	Polarity	Voltage (kV)	Test Mode	Performance criteria
a.c. power, L-N	+/-	1.0	Mode 1	A
A: No degradation in the performance of the EUT was observed.				

#### 15.5. PERFORMANCE

<input checked="" type="checkbox"/> <b>Criteria A:</b>	The apparatus continues to operate as intended. No degradation of performance or loss of function is allowed below a performance level specified by the manufacturer, when the apparatus is used as intended. In some cases the performance level may be replaced by a permissible loss of performance.
<input type="checkbox"/> <b>Criteria B:</b>	The apparatus continues to operate as intended after the test. No degradation of performance or loss of function is allowed below a performance level specified by the manufacturer, when the apparatus is used as intended. In some cases the performance level may be replaced by a permissible loss of performance. During the test, degradation of performance is however allowed.
<input type="checkbox"/> <b>Criteria C:</b>	Temporary loss of function is allowed, provided the functions self recoverable or can be restored by the operation of controls.

**PASS**                       **FAIL**

Any report having not been signed by authorized approver, or having been altered without authorization, or having not been stamped by the "Dedicated Testing/Inspection Stamp" is deemed to be invalid. Copying or excerpting portion of, or altering the content of the report is not permitted without the written authorization of AGC. The test results presented in the report apply only to the tested sample. Any objections to report issued by AGC should be submitted to AGC within 15days after the issuance of the test report. Further enquiry of validity or verification of the test report should be addressed to AGC by agc01@agccert.com.

## 16. IMMUNITY TO CONDUCTED DISTURBANCES INDUCED BY RF FIELDS

### 16.1. TEST SPECIFICATION

<b>Basic Standard</b>	EN 61000-4-6
<b>Frequency Range</b>	0.15 MHz – 80 MHz
<b>Field Strength</b>	3Vrms
<b>Modulation</b>	1 kHz Sine Wave, 80% AM
<b>Frequency Step</b>	1% of fundamental
<b>Coupled Cable</b>	a.c. power line
<b>Coupling Device</b>	CDN-M2

### 16.2. TEST PROCEDURE

1. The EUT shall be tested within its intended operating and climatic conditions.
2. The test shall be performed with the test generator connected to each of the coupling and decoupling devices in turn, while the other non-excited RF input ports of the coupling devices are terminated by a 50-ohm load resistor.
3. The test signal was 80% amplitude modulated with a 1 kHz sine wave
4. The frequency range is swept from 150 kHz to 80 MHz, using the signal level established during the setting process and with a disturbance signal of 80% amplitude. The sweep rate shall not exceed  $1.5 \times 10^{-3}$  decades/s. The step size shall not exceed 1% of the start and thereafter 1% of the preceding frequency value where the frequency is swept incrementally.
5. The dwell time at each frequency shall not be less than the time necessary for the EUT to be exercised, and able to respond. Sensitive frequencies such as clock frequencies and harmonics or frequencies of dominant interest, shall be analyzed separately.
6. Attempts should be made to fully exercise the EUT during test, and to fully interrogate all exercise modes selected for susceptibility.

### 16.3. TEST SETUP

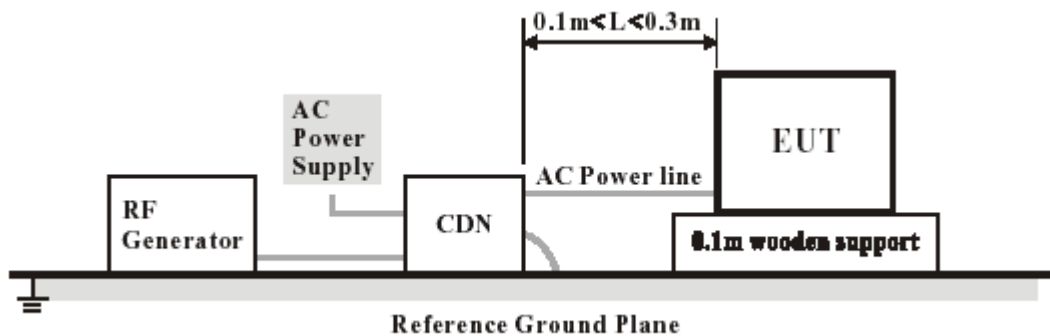

For the actual test configuration, please refer to Appendix A: Photographs of the Test Configuration.



#### 16.4. TEST RESULT

Test Point	Frequency (MHz)	Level (V rms)	Test Mode	Performance criteria
a.c. port	0.15 – 80	3	Mode 1	A
A: No degradation in the performance of the EUT was observed.				

#### 16.5. PERFORMANCE

<input checked="" type="checkbox"/> <b>Criteria A:</b>	The apparatus continues to operate as intended. No degradation of performance or loss of function is allowed below a performance level specified by the manufacturer, when the apparatus is used as intended. In some cases the performance level may be replaced by a permissible loss of performance.
<input type="checkbox"/> <b>Criteria B:</b>	The apparatus continues to operate as intended after the test. No degradation of performance or loss of function is allowed below a performance level specified by the manufacturer, when the apparatus is used as intended. In some cases the performance level may be replaced by a permissible loss of performance. During the test, degradation of performance is however allowed.
<input type="checkbox"/> <b>Criteria C:</b>	Temporary loss of function is allowed, provided the functions self recoverable or can be restored by the operation of controls.

**PASS**                       **FAIL**

Any report having not been signed by authorized approver, or having been altered without authorization, or having not been stamped by the "Dedicated Testing/Inspection Stamp" is deemed to be invalid. Copying or excerpting portion of, or altering the content of the report is not permitted without the written authorization of AGC. The test results presented in the report apply only to the tested sample. Any objections to report issued by AGC should be submitted to AGC within 15days after the issuance of the test report. Further enquiry of validity or verification of the test report should be addressed to AGC by agc01@agccert.com.

## 17. VOLTAGE DIPS AND SHORT INTERRUPTIONS IMMUNITY TEST

### 17.1. TEST SPECIFICATION

<b>Basic Standard</b>	EN 61000-4-11
<b>Voltage Dips</b>	100% reduction, 0.5 Cycle 100% reduction, 1.0 Cycle 30% reduction, 25 Cycles
<b>Voltage Interruptions</b>	100% reduction, 250 Cycles
<b>Voltage Phase Angle</b>	0°, 45°, 90°, 135°, 180°, 225°, 270°, 315°

### 17.2. TEST PROCEDURE

- The power cord was used as supplied by the manufacturer. The EUT was connected to the line output of the Voltage Dips and Interruption Generator.
- The EUT was tested for (1) 100% voltage dip of supplied voltage with duration of 0.5 cycles, (2) 100% voltage dip of supplied voltage and duration 1.0 cycle. (3) 30% voltage dip of supplied voltage and duration 25 cycles. (4) 100% voltage interruption of supplied voltage with duration of 250 Cycles was followed.
- Voltage reductions occur at 0 degree crossover point of the voltage waveform. The performance of the EUT was checked after the voltage dip or interruption.

### 17.3. TEST SETUP

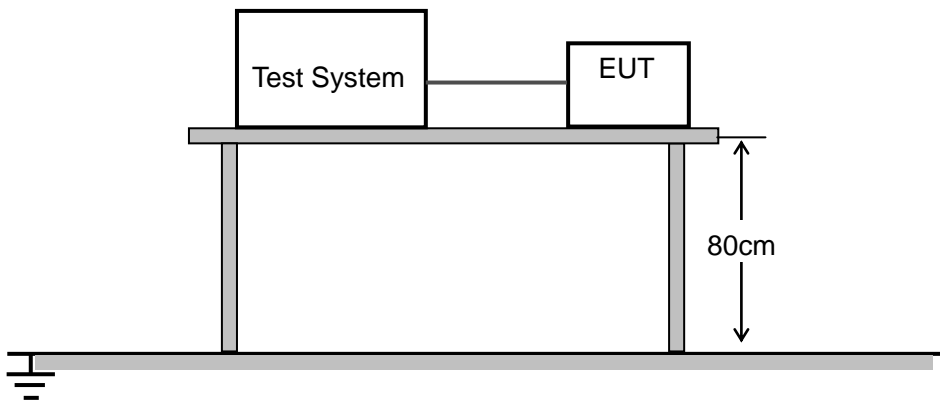

For the actual test configuration, please refer to Appendix A, Photographs of the Test Configuration.

#### 17.4. TEST RESULT

Test Mode	Voltage Reduction	Duration (cycle)	Times	Interval (Sec)	Test Mode	Performance criteria
Voltage dips	100%	0.5	3	10	Mode 1	B
	100%	1	3	10	Mode 1	B
	30%	25	3	10	Mode 1	B
Voltage interruptions	100%	250	3	10	Mode 1	C

A: No degradation in the performance of the EUT was observed.

B: Stop charging during the test and self-recoverable after test.

C: Lost functions can be recoverable by user or operator.

#### 17.5. PERFORMANCE

<input type="checkbox"/> <b>Criteria A:</b>	The apparatus continues to operate as intended. No degradation of performance or loss of function is allowed below a performance level specified by the manufacturer, when the apparatus is used as intended. In some cases the performance level may be replaced by a permissible loss of performance.
<input checked="" type="checkbox"/> <b>Criteria B:</b>	The apparatus continues to operate as intended after the test. No degradation of performance or loss of function is allowed below a performance level specified by the manufacturer, when the apparatus is used as intended. In some cases the performance level may be replaced by a permissible loss of performance. During the test, degradation of performance is however allowed.
<input checked="" type="checkbox"/> <b>Criteria C:</b>	Temporary loss of function is allowed, provided the functions self recoverable or can be restored by the operation of controls.

**PASS**

**FAIL**

## APPENDIX A: PHOTOGRAPHS OF TEST SETUP

### LINE CONDUCTED EMISSION TEST SETUP

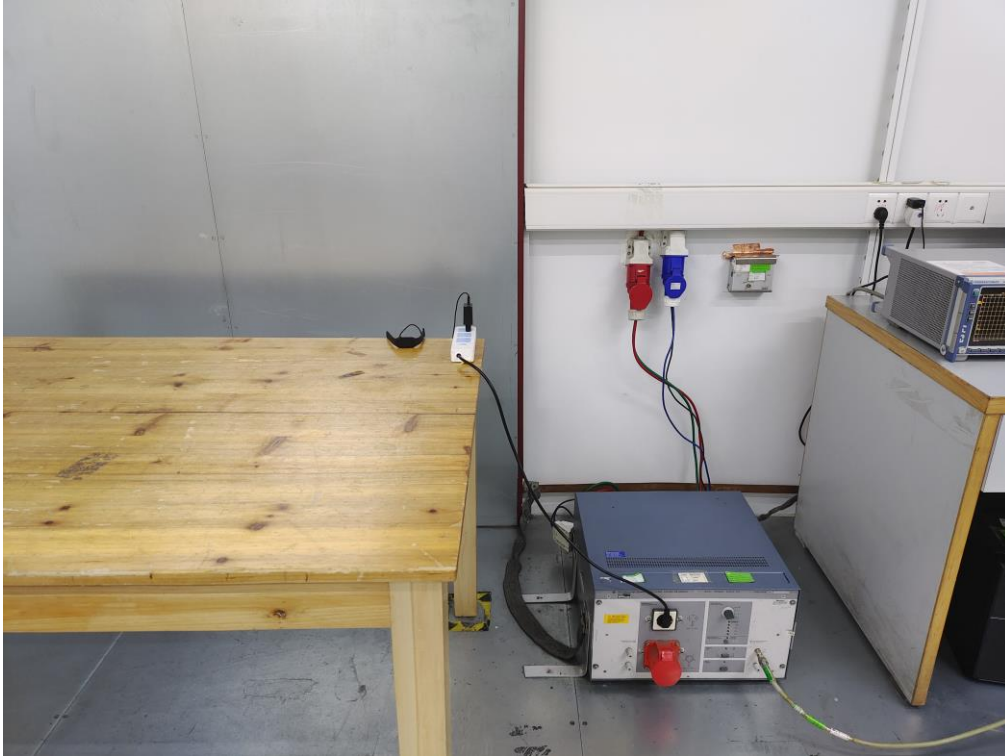

RADIATED EMISSION TEST SETUP (BELOW 1GHz)

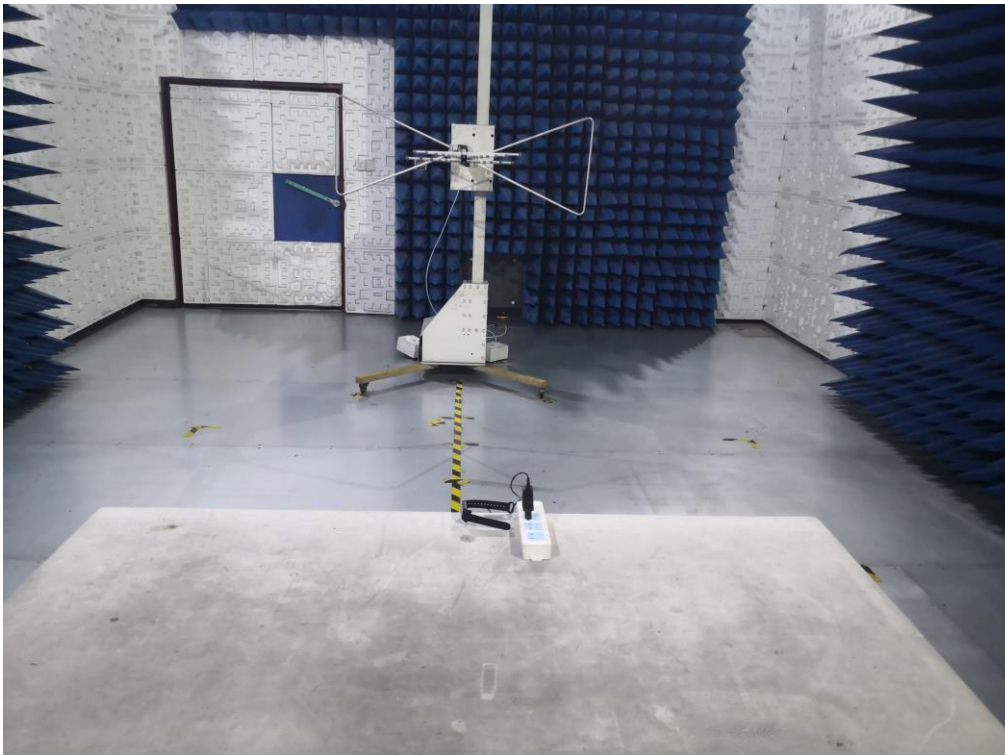

Any report having not been signed by authorized approver, or having been altered without authorization, or having not been stamped by the “Dedicated Testing/Inspection Stamp” is deemed to be invalid. Copying or excerpting portion of, or altering the content of the report is not permitted without the written authorization of AGC. The test results presented in the report apply only to the tested sample. Any objections to report issued by AGC should be submitted to AGC within 15days after the issuance of the test report. Further enquiry of validity or verification of the test report should be addressed to AGC by [agc01@agccert.com](mailto:agc01@agccert.com).

### RADIATED EMISSION TEST SETUP (ABOVE 1GHz)

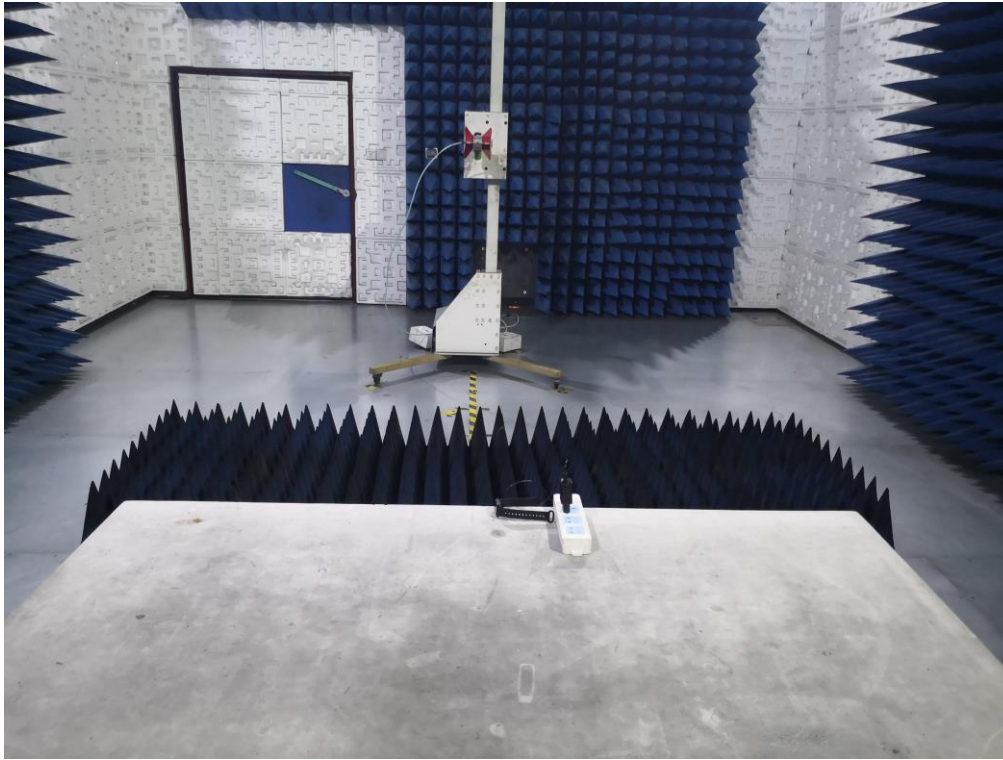

### EN 61000-4-2 ESD TEST SETUP



Any report having not been signed by authorized approver, or having been altered without authorization, or having not been stamped by the “Dedicated Testing/Inspection Stamp” is deemed to be invalid. Copying or excerpting portion of, or altering the content of the report is not permitted without the written authorization of AGC. The test results presented in the report apply only to the tested sample. Any objections to report issued by AGC should be submitted to AGC within 15days after the issuance of the test report. Further enquiry of validity or verification of the test report should be addressed to AGC by [agc01@agccert.com](mailto:agc01@agccert.com).

### EN61000-3-3 VOLTAGE FLUCTUATION / FLICKER TEST SETUP



EN 61000-4-3 RS TEST SETUP (BELOW 1GHz)

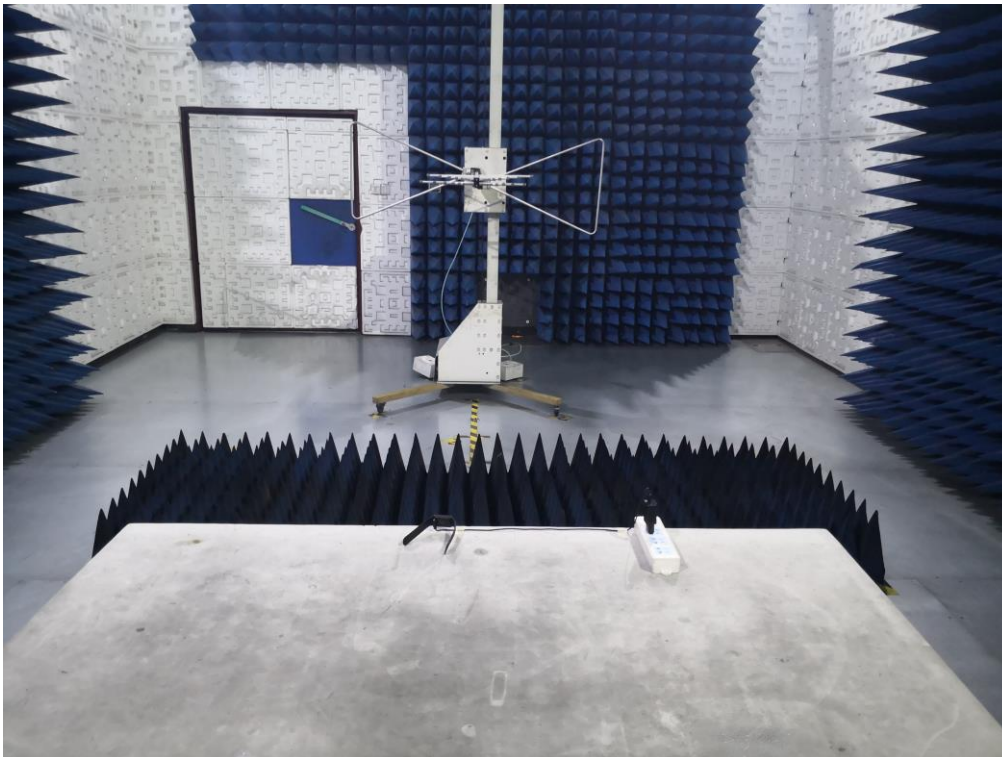

Any report having not been signed by authorized approver, or having been altered without authorization, or having not been stamped by the “Dedicated Testing/Inspection Stamp” is deemed to be invalid. Copying or excerpting portion of, or altering the content of the report is not permitted without the written authorization of AGC. The test results presented in the report apply only to the tested sample. Any objections to report issued by AGC should be submitted to AGC within 15days after the issuance of the test report. Further enquiry of validity or verification of the test report should be addressed to AGC by [agc01@agccert.com](mailto:agc01@agccert.com).

EN 61000-4-3 RS TEST SETUP (ABOVE 1GHz)

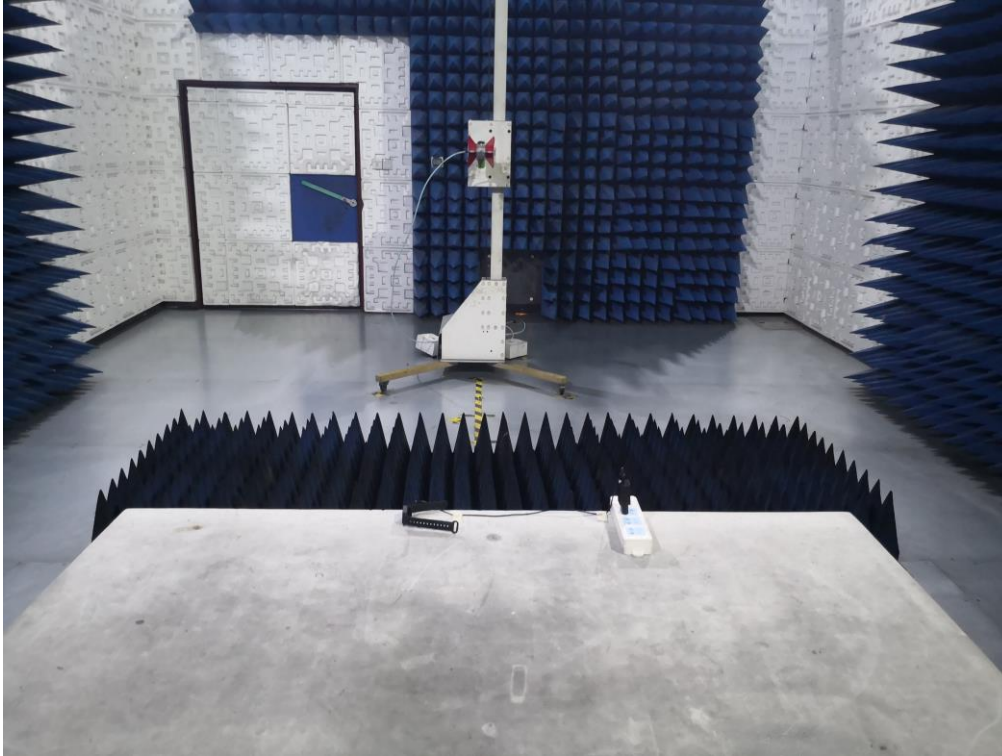

EN 61000-4-6 CS IMMUNITY TEST SETUP



Any report having not been signed by authorized approver, or having been altered without authorization, or having not been stamped by the “Dedicated Testing/Inspection Stamp” is deemed to be invalid. Copying or excerpting portion of, or altering the content of the report is not permitted without the written authorization of AGC. The test results presented in the report apply only to the tested sample. Any objections to report issued by AGC should be submitted to AGC within 15days after the issuance of the test report. Further enquiry of validity or verification of the test report should be addressed to AGC by [agc01@agccert.com](mailto:agc01@agccert.com).

## EN 61000-4-4/-5/-11 EFT/SURGE/DIPS TEST SETUP

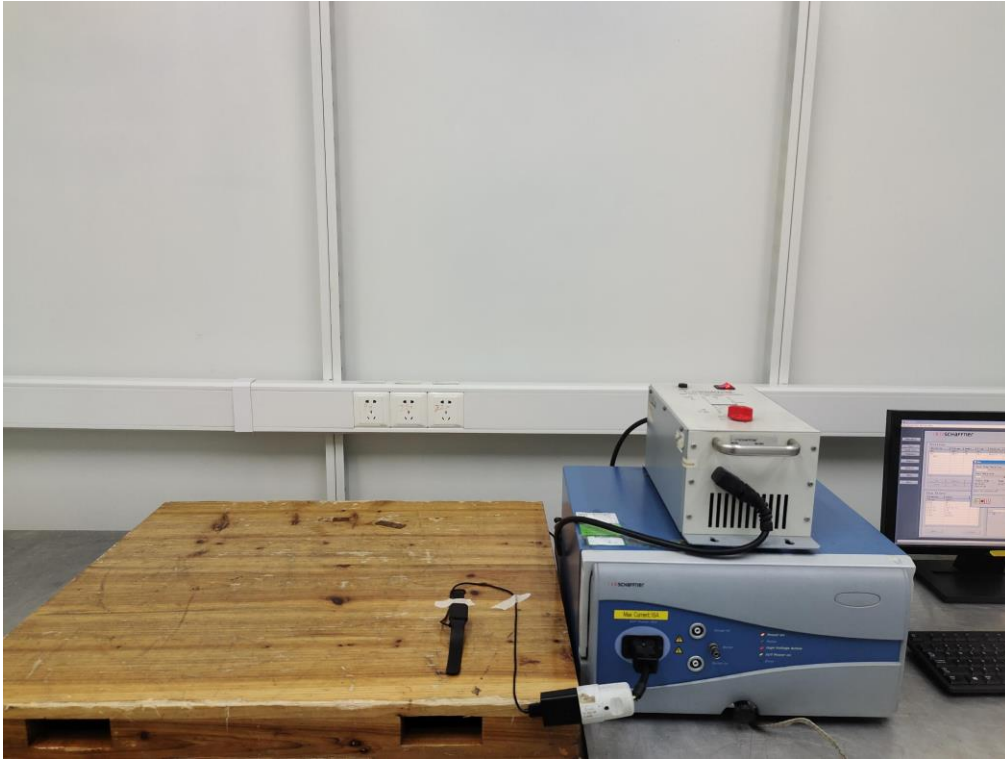

Any report having not been signed by authorized approver, or having been altered without authorization, or having not been stamped by the “Dedicated Testing/Inspection Stamp” is deemed to be invalid. Copying or excerpting portion of, or altering the content of the report is not permitted without the written authorization of AGC. The test results presented in the report apply only to the tested sample. Any objections to report issued by AGC should be submitted to AGC within 15days after the issuance of the test report. Further enquiry of validity or verification of the test report should be addressed to AGC by [agc01@agccert.com](mailto:agc01@agccert.com).



## **APPENDIX B: PHOTOGRAPHS OF EUT**

Refer to the Report No.: AGC00550220603AP01

**----END OF REPORT----**

Any report having not been signed by authorized approver, or having been altered without authorization, or having not been stamped by the “Dedicated Testing/Inspection Stamp” is deemed to be invalid. Copying or excerpting portion of, or altering the content of the report is not permitted without the written authorization of AGC. The test results presented in the report apply only to the tested sample. Any objections to report issued by AGC should be submitted to AGC within 15days after the issuance of the test report. Further enquiry of validity or verification of the test report should be addressed to AGC by [agc01@agccert.com](mailto:agc01@agccert.com).

Attestation of Global Compliance(Shenzhen)Co., Ltd  
Attestation of Global Compliance(Shenzhen)Std & Tech Co., Ltd  
Tel: +86-755 2523 4088 E-mail: [agc@agccert.com](mailto:agc@agccert.com) Web: <http://www.agccert.com/>



## Conditions of Issuance of Test Reports

1. All samples and goods are accepted by the Attestation of Global Compliance (Shenzhen) Co., Ltd. (the “Company”) solely for testing and reporting in accordance with the following terms and conditions. The company provides its services on the basis that such terms and conditions constitute express agreement between the company and any person, firm or company requesting its services (the “Clients”).
2. Any report issued by Company as a result of this application for testing services (the “Report”) shall be issued in confidence to the Clients and the Report will be strictly treated as such by the Company. It may not be reproduced either in its entirety or in part and it may not be used for advertising or other unauthorized purposes without the written consent of the Company. The Clients to whom the Report is issued may, however, show or send it, or a certified copy thereof prepared by the Company to its customer, supplier or other persons directly concerned. The Company will not, without the consent of the Clients, enter into any discussion or correspondence with any third party concerning the contents of the Report, unless required by the relevant governmental authorities, laws or court orders.
3. The Company shall not be called or be liable to be called to give evidence or testimony on the Report in a court of law without its prior written consent, unless required by the relevant governmental authorities, laws or court orders.
4. In the event of the improper use of the report as determined by the Company, the Company reserves the right to withdraw it, and to adopt any other additional remedies which may be appropriate.
5. Samples submitted for testing are accepted on the understanding that the Report issued cannot form the basis of, or be the instrument for, any legal action against the Company.
6. The Company will not be liable for or accept responsibility for any loss or damage however arising from the use of information contained in any of its Reports or in any communication whatsoever about its said tests or investigations.
7. Clients wishing to use the Report in court proceedings or arbitration shall inform the Company to that effect prior to submitting the sample for testing.
8. The Company is not responsible for recalling the electronic version of the original report when any revision is made to them. The Client assumes the responsibility to providing the revised version to any interested party who uses them.
9. Subject to the variable length of retention time for test data and report stored hereinto as otherwise specifically required by individual accreditation authorities, the Company will only keep the supporting test data and information of the test report for a period of six years. The data and information will be disposed of after the aforementioned retention period has elapsed. Under no circumstances shall we provide any data and information which has been disposed of after retention period. Under no circumstances shall we be liable for damage of any kind, including (but not limited to) compensatory damages, lost profits, lost data, or any form of special, incidental, indirect, consequential or punitive damages of any kind, whether based on breach of contract of warranty, tort (including negligence), product liability or otherwise, even if we are informed in advance of the possibility of such damages.

Any report having not been signed by authorized approver, or having been altered without authorization, or having not been stamped by the “Dedicated Testing/Inspection Stamp” is deemed to be invalid. Copying or excerpting portion of, or altering the content of the report is not permitted without the written authorization of AGC. The test results presented in the report apply only to the tested sample. Any objections to report issued by AGC should be submitted to AGC within 15days after the issuance of the test report. Further enquiry of validity or verification of the test report should be addressed to AGC by [agc01@agccert.com](mailto:agc01@agccert.com).