



# EMC TEST REPORT

**ETSI EN 301 489-1 V2.2.3 (2019-11)**  
**ETSI EN 301 489-17 V3.1.1 (2017-02)**  
**EN 55032:2015**  
**EN 55035:2017**  
**EN 61000-3-2:2014**  
**EN 61000-3-3:2013**

**Product :** Computer Multimedia Speaker

**Trade Mark :** F&D

**Model Name :** R23BT

**Family Model :** R20BT, R24BT

**Report No. :** S20071700202001

## Prepared for

SHENZHEN FENDA TECHNOLOGY CO., LTD.

Fenda Hi-Tech Park, Zhoushi Road, Shiyan Town, Baoan District,  
Shenzhen City, Guangdong, China

## Prepared by

Shenzhen NTEK Testing Technology Co., Ltd.

1/F, Building E, Fenda Science Park, Sanwei Community, Xixiang Street  
Bao'an District, Shenzhen 518126 P.R. China

Tel.: +86-755-6115 6588 Fax.: +86-755-6115 6599

Website: <http://www.ntek.org.cn>

**TEST RESULT CERTIFICATION**

**Applicant's name**.....: SHENZHEN FENDA TECHNOLOGY CO., LTD.  
**Address**.....: Fenda Hi-Tech Park, Zhoushi Road, Shiyang Town, Baoan District, Shenzhen City, Guangdong, China  
**Manufacturer's Name**.....: SHENZHEN FENDA TECHNOLOGY CO., LTD.  
**Address**.....: Fenda Hi-Tech Park, Zhoushi Road, Shiyang Town, Baoan District, Shenzhen City, Guangdong, China

**Product description**

**Product name** .....: Computer Multimedia Speaker  
**Trademark** .....: F&D  
**Model Name** .....: R23BT  
**Family Model** : R20BT, R24BT

**Standards**.....: ETSI EN 301 489-1 V2.2.3 (2019-11)  
 ETSI EN 301 489-17 V3.1.1 (2017-02)  
 EN 55032:2015  
 EN 55035:2017  
 EN 61000-3-2:2014  
 EN 61000-3-3:2013

This device described above has been tested by NTEK, and the test results show that the equipment under test (EUT) is in compliance with the of article 3.1(b) of the Directive 2014/53/EU requirements. And it is applicable only to the tested sample identified in the report. This report shall not be reproduced except in full, without the written approval of NTEK, this document may be altered or revised by NTEK, personnel only, and shall be noted in the revision of the document.

**Date of Test**.....  
 Date (s) of performance of tests ... 17 Jul. 2020 ~ 14 Aug. 2020  
 Date of Issue ..... 14 Aug. 2020  
 Test Result ..... **Pass**

Testing Engineer :   
 (Mary Hu)

Technical Manager :   
 (Jason Chen)

Authorized Signatory :   
 (Alex Li)



**Table of Contents**

**Page**

<b>1 . TEST SUMMARY</b>	<b>5</b>
1.1 TEST FACILITY	7
1.2 MEASUREMENT UNCERTAINTY	7
<b>2 . GENERAL INFORMATION</b>	<b>9</b>
2.1 DESCRIPTION OF TEST MODES	10
2.2 DESCRIPTION OF TEST SETUP	11
2.3 DESCRIPTION TEST PERIPHERAL AND EUT PERIPHERAL	12
2.4 MEASUREMENT INSTRUMENTS LIST	13
<b>3 . EMC EMISSION TEST</b>	<b>18</b>
3.1 CONDUCTED EMISSION MEASUREMENT	18
3.1.1 POWER LINE CONDUCTED EMISSION	18
3.1.2 TEST PROCEDURE	21
3.1.3 TEST SETUP	21
3.1.4 EUT OPERATING CONDITIONS	21
3.1.5 TEST RESULTS	22
3.2 RADIATED EMISSION MEASUREMENT	24
3.2.1 LIMITS OF RADIATED EMISSION MEASUREMENT	24
3.2.2 LIMITS OF RADIATED EMISSION MEASUREMENT	25
3.2.3 TEST PROCEDURE	25
3.2.4 TEST SETUP	26
3.2.5 EUT OPERATING CONDITIONS	26
3.2.6 TEST RESULTS (30-1000MHz)	27
3.2.7 TEST RESULTS(1000-6000MHz)	29
3.3 HARMONICS CURRENT	30
3.3.1 LIMITS OF HARMONICS CURRENT	30
3.3.2 TEST PROCEDURE	31
3.3.3 EUT OPERATING CONDITIONS	31
3.3.4 TEST SETUP	31
3.3.5 TEST RESULTS	32
3.4 VOLTAGE FLUCTUATION AND FLICKERS	33
3.4.1 LIMITS OF VOLTAGE FLUCTUATION AND FLICKERS	33
3.4.2 TEST PROCEDURE	33
3.4.3 EUT OPERATING CONDITIONS	33
3.4.4 TEST SETUP	34
<b>4 . EMC IMMUNITY TEST</b>	<b>36</b>
4.1 GENERAL PERFORMANCE CRITERIA	36
4.1.1 PERFORMANCE CRITERIA	36

<b>Table of Contents</b>	<b>Page</b>
4.2 GENERAL PERFORMANCE CRITERIA TEST SETUP	38
4.3 ESD TESTING	39
4.3.1 TEST SPECIFICATION	39
4.3.2 TEST PROCEDURE	39
4.3.3 TEST SETUP	40
4.3.4 TEST RESULTS	41
4.4 RS TESTING	43
4.4.1 TEST SPECIFICATION	43
4.4.2 TEST PROCEDURE	43
4.4.3 TEST SETUP	44
4.4.4 TEST RESULTS	45
4.5 EFT/BURST TESTING	49
4.5.1 TEST SPECIFICATION	49
4.5.2 TEST PROCEDURE	49
4.5.3 TEST SETUP	50
4.5.4 TEST RESULTS	51
4.6 SURGE TESTING	53
4.6.1 TEST SPECIFICATION	53
4.6.2 TEST PROCEDURE	53
4.6.3 TEST SETUP	54
4.6.4 TEST RESULTS	55
4.7 INJECTION CURRENT TESTING	57
4.7.1 TEST SPECIFICATION	57
4.7.2 TEST PROCEDURE	57
4.7.3 TEST SETUP	57
4.7.4 TEST RESULTS	59
4.8 VOLTAGE INTERRUPTION/DIPS TESTING	61
4.8.1 TEST SPECIFICATION	61
4.8.2 TEST PROCEDURE	61
4.8.3 TEST SETUP	61
4.8.4 TEST RESULTS	62
5 . EUT TEST PHOTO	63

### 1. TEST SUMMARY

Test procedures according to the technical standards:				
ETSI EN 301 489-1 V2.2.3 (2019-11)				
ETSI EN 301 489-17 V3.1.1 (2017-02)				
EN 55032:2015; EN 55035:2017				
EN 61000-3-2:2014; EN 61000-3-3:2013				
EMC Emission				
Standard	Test Item	Limit	Judgment	Remark
EN 55032:2015	Conducted Emission On AC And Telecom Port 150kHz to 30MHz	Class B	PASS	
	Disturbance Voltage at The Antenna Terminals (30MHz To 2150MHz)	-----	N/A	
	Wanted signal and disturbance voltage at the RF output terminals (30MHz To 2150MHz)	-----	N/A	
	Radiated Emission 30MHz to 1000MHz	Class B	PASS	
	Radiated Emission 1GHz to 6GHz	Class B	PASS	
EN61000-3-2:2014	Harmonic Current Emission	Class A	N/A	
EN 61000-3-3:2013	Voltage Fluctuations & Flicker	-----	PASS	
EMC Immunity				
Section EN 55035:2017	Test Item	Performance Criteria	Judgment	Remark
EN 61000-4-2:2009	Electrostatic Discharge	B	PASS	
EN 61000-4-3:2006+A1:2008+A2:2010	RF electromagnetic field	A	PASS	
EN 61000-4-4:2012	Fast transients	B	PASS	
EN 61000-4-5:2006	Surges	B	PASS	
EN 61000-4-6:2009	Continuous radio frequency disturbances or Injected Current	A	PASS	
EN 61000-4-8:2010	Power Frequency Magnetic Field	A	N/A	NOTE (3)
EN 61000-4-11:2004	Volt. Interruptions Volt. Dips	B / C / C NOTE (2)	PASS	

**NOTE:**

- (1) "N/A" denotes test is not applicable in this Test Report
- (2) Voltage dip: 100% reduction – Performance Criteria **B**  
Voltage dip: 30% reduction – Performance Criteria **C**  
Voltage Interruption: 100% Interruption – Performance Criteria **C**
- (3) Applicable only to equipment containing devices intrinsically susceptible to magnetic fields, such as CRT monitors, Hall effect elements, electro-dynamic microphones, magnetic field sensors or audio frequency transformers.
- (4) For client's request and manual description, the test will not be executed.



1.1 TEST FACILITY

Shenzhen NTEK Testing Technology Co., Ltd.  
 Add. : 1/F, Building E, Fenda Science Park, Sanwei Community, Xixiang Street  
 Bao'an District, Shenzhen 518126 P.R. China

CNAS-Lab. : The Laboratory has been assessed and proved to be in compliance with CNAS-CL01:2006 (identical to ISO/IEC 17025:2005)  
 The Certificate Registration Number is L5516

IC-Registration : The Certificate Registration Number is 9270A-1

FCC- Accredited : Test Firm Registration Number: 463705  
 Designation Number: CN1184

A2LA-Lab. : The Certificate Registration Number is 4298.01  
 This laboratory is accredited in accordance with the recognized International Standard ISO/IEC 17025:2005 General requirements for the competence of testing and calibration laboratories.  
 This accreditation demonstrates technical competence for a defined scope and the operation of a laboratory quality management system (refer to joint ISO-ILAC-IAF Communiqué dated 8 January 2009).

1.2 MEASUREMENT UNCERTAINTY

The reported uncertainty of measurement  $y \pm U$ , where expended uncertainty  $U$  is based on a standard uncertainty multiplied by a coverage factor of  $k=2$ , providing a level of confidence of approximately 95 % .

Test Item	Measurement Frequency Range	K	U(dB)
AC Mains Conducted Emission	0.009kHz ~ 0.15MHz	2	2.66
AC Mains Conducted Emission	0.15MH ~ 30MHz	2	2.80
Telecom Conducted Emission (Cat 3)	0.15MHz ~ 30MHz	2	2.40
Telecom Conducted Emission (Cat 5)	0.15MHz ~ 30MHz	2	2.58
Radiated Emission	30MHz ~ 1000MHz	2	2.64
Radiated Emission	1000MHz ~ 6000MHz	2	2.40
Radiated Emission	6000MHz ~ 18000MHz	2	2.52





## 2. GENERAL INFORMATION

### 2.1 GENERAL DESCRIPTION OF EUT

Equipment	Computer Multimedia Speaker
Trade Mark	F&D
Model Name	R23BT
Family Model	R20BT, R24BT
Model Difference	All the model are the same circuit and RF module, except the exterior and color difference
Frequency Bands:	<input checked="" type="checkbox"/> BT: 2402-2480 MHz
Modulation Mode:	<input checked="" type="checkbox"/> BT(1Mbps): GFSK <input checked="" type="checkbox"/> BT EDR(2Mbps): $\pi/4$ -DQPSK
Power Rating	AC 100-240V 50/60Hz 0.3A
Battery	N/A
Adapter	N/A
Connecting I/O Port(s)	Please refer to the User's Manual
Antenna:	PCB Antenna
Hard Ware Version	N/A
Soft Ware Version	N/A

## 2.1 DESCRIPTION OF TEST MODES

To investigate the maximum EMI emission characteristics generates from EUT, the test system was pre-scanning tested base on the consideration of following EUT operation mode or test configuration mode which possible have effect on EMI emission level. Each of these EUT operation mode(s) or test configuration mode(s) mentioned above was evaluated respectively.

Pretest Mode	Description
Mode 1	USB
Mode 2	AUX IN
Mode 3	Optical
Mode 4	BT link

For Conducted Test	
Final Test Mode	Description
Mode 1	USB

For Radiated Test	
Final Test Mode	Description
Mode 1	USB

For EMS Test	
Pretest Mode	Description
Mode 1	USB
Mode 2	AUX IN
Mode 3	Optical
Mode 4	BT link

NOTE: The test modes were carried out for all operation modes. The final test mode of the EUT was the worst test mode for EMI, and its test data was showed.

2.2 DESCRIPTION OF TEST SETUP  
CE

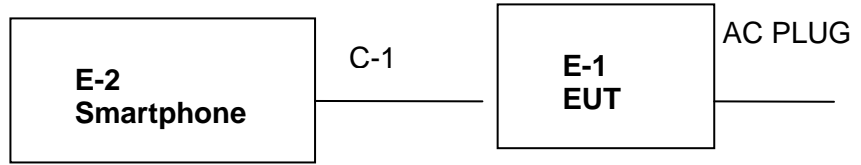

RE

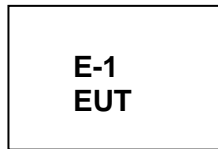



**2.3 DESCRIPTION TEST PERIPHERAL AND EUT PERIPHERAL**

The EUT has been tested as an independent unit together with other necessary accessories or support units. The following support units or accessories were used to form a representative test configuration during the tests.

Item	Equipment	Brand	Model/Type No.	Series No.	Note
E-1	Computer Multimedia Speaker	F&D	R23BT	N/A	EUT
E-2	Smartphone	N/A	N/A	N/A	Peripherals

Item	Cable Type	Shielded Type	Ferrite Core	Length	Note
C-1	Usb cable	NO	NO	1.0m	

Note:

- (1) The support equipment was authorized by Declaration of Confirmation.
- (2) For detachable type I/O cable should be specified the length in cm in 『Length』 column.

## 2.4 MEASUREMENT INSTRUMENTS LIST

### 2.4.1 CONDUCTED EMISSION

Item	Kind of Equipment	Manufacturer	Type No.	Serial No.	Last calibration	Calibrated until	Calibration period
1	Test Cable	N/A	C01	N/A	May 13, 2020	May 12, 2021	3 years
2	Test Cable	N/A	C02	N/A	May 13, 2020	May 12, 2021	3 years
3	Test Cable	N/A	C03	N/A	May 13, 2020	May 12, 2021	3 years
4	Pulse Limiter	SCHWARZBECK	VTSD 9561F	9716	May 13, 2020	May 12, 2021	1 year
5	50Ω Switch	ANRITSU CORP	MP59B	6200983704	May 13, 2020	May 12, 2021	1 year
6	EMI Test Receiver	R&S	ESCI	101160	May 13, 2020	May 12, 2021	1 year
7	Unversal radio communication tester	R&S	CMU200	1100.008.02	May 13, 2020	May 12, 2021	1 year
8	Wideband Radio Communication Tester Specifications	R&S	CMW500	148500	May 13, 2020	May 12, 2021	1 year
9	LISN	SCHWARZBECK	NNLK 8129	8129245	May 13, 2020	May 12, 2021	1 year
10	LISN	R&S	ENV216	101313	May 13, 2020	May 12, 2021	1 year

### 2.4.2 RADIATED TEST SITE

Item	Kind of Equipment	Manufacturer	Type No.	Serial No.	Last calibration	Calibrated until	Calibration period
1	Antenna Mast	EM	SC100_1	N/A	N/A	N/A	N/A
2	Turn Table	EM	SC100	060531	N/A	N/A	N/A
3	EMI Test Receiver	R&S	ESCI-7	101318	May 13, 2020	May 12, 2021	1 year
4	50Ω Switch	Anritsu Corp	MP59B	6200983705	May 13, 2020	May 12, 2021	1 year
5	Spectrum Analyzer	Aglient	E4407B	MY45108040	May 13, 2020	May 12, 2021	1 year
6	Unversal radio communication tester	R&S	CMU200	1100.008.02	May 13, 2020	May 12, 2021	1 year
7	Wideband Radio Communication Tester Specifications	R&S	CMW500	148500	May 13, 2020	May 12, 2021	1 year
8	Test Cable	N/A	R-01	N/A	May 13, 2020	May 12, 2021	3 years
9	Test Cable	N/A	R-02	N/A	May 13, 2020	May 12, 2021	3 years
10	Bilog Antenna	TESEQ	CBL6111D	31216	May 13, 2020	May 12, 2021	1 year

11	Horn Antenna	EM	EM-AH-101 80	201107140 2	Nov. 08. 2018	Nov. 07. 2021	1 year
12	Amplifier	EMC	EMC05183 5SE	980246	Nov. 08. 2018	Nov. 07. 2021	1 year
13	Wideband Radio Communication Tester Specifications	R&S	CMW500	148500	May 13, 2020	May 12, 2021	1 year

2.4.3 HARMONICS AND FILCK

Item	Kind of Equipment	Manufacturer	Type No.	Serial No.	Last calibration	Calibrated until	Calibration period
1	Harmonic & Flicker	EM TEST	DPA500	0303-04	May 13, 2020	May 12, 2021	1 year
2	AC Power Source	EM TEST	ACS500	0203-01	May 13, 2020	May 12, 2021	1 year
3	Unversal radio communication tester	R&S	CMU200	1100.008.02	May 13, 2020	May 12, 2021	1 year
4	Wideband Radio Communication Tester Specifications	R&S	CMW500	148500	May 13, 2020	May 12, 2021	1 year

2.4.4 ESD

Item	Kind of Equipment	Manufacturer	Type No.	Serial No.	Last calibration	Calibrated until	Calibration period
1	Unversal radio communication tester	R&S	CMU200	1100.008.0 2	May 13, 2020	May 12, 2021	1 year
2	Wideband Radio Communication Tester Specifications	R&S	CMW500	148500	May 13, 2020	May 12, 2021	1 year
3	Electrostatic Discharge Generator	Lioncel	ESD-203B	ESD203B0 150402	May 13, 2020	May 12, 2021	1 year



2.4.5 RS

Item	Kind of Equipment	Manufacturer	Type No.	Serial No.	Last calibration	Calibrated until	Calibration period
1	PSG Analog Signal Generator	Agilent	E8257D	MY51110112	Nov. 04, 2019	Nov. 05, 2020	1 year
2	Bilog Antenna	ETS	3142E(Frequency range 30MHz to 6 GHz)	00214344	Nov. 02, 2019	Nov. 03, 2020	1 year
3	Power Amplifier	rflight	NTWPA-00810200	17063153	Aug. 04, 2019	Aug. 05, 2020	1 year
4	Broadband Amplifier	AR	60S1G6	0350414	Nov. 02, 2019	Nov. 03, 2020	1 year
5	Power Amplifier	AR	25S1G4A	308598	Aug. 04, 2019	Aug. 05, 2020	1 year
6	Unversal radio communication tester	R&S	CMU200	1100.008.02	May 13, 2020	May 12, 2021	1 year
7	Audio Power Amplifier	Brüel & Kjær	4602B	2185667	May 13, 2020	May 12, 2021	1 year
8	Mouth Simulator	Brüel & Kjær	2669	2143265	May 13, 2020	May 12, 2021	1 year
9	Sound Calibrator	Brüel & Kjær	4185	2194825	May 13, 2020	May 12, 2021	1 year
10	1/2" Pressure-field Microphone	Brüel & Kjær	735	2641678	May 13, 2020	May 12, 2021	1 year
11	Wideband Radio Communication Tester Specifications	R&S	CMW500	148500	May 13, 2020	May 12, 2021	1 year
12	Telephone Test Head	Brüel & Kjær	4185	2631728	May 13, 2020	May 12, 2021	1 year
13	Audio Analyzer	R&S	UPV	100419	May 13, 2020	May 12, 2021	1 year
14	Ear Simulator for Telephonometry	Brüel & Kjær	4185	2553612	May 13, 2020	May 12, 2021	1 year
15	Power Meter	Agilent	E4419B	MY45102538	Jul. 17, 2020	Jul. 16, 2021	1 year
16	Power Sensor	Agilent	E9301A	MY41495644	Jul. 17, 2020	Jul. 16, 2021	1 year
17	Power Sensor	Agilent	E9301A	US39212148	Jul. 17, 2020	Jul. 16, 2021	1 year

2.4.6 SURGE, EFT/BURST, VOLTAGE INTERRUPTION/DIPS

Item	Kind of Equipment	Manufacturer	Type No.	Serial No.	Last calibration	Calibrated until	Calibration period
1	Surge Generator	EVERFINE	EMS61000-5A-V1	1101002	May 13, 2020	May 12, 2021	1 year
2	DIPS Generator	EVERFINE	EMS61000-11K	1011002	May 13, 2020	May 12, 2021	1 year
3	EFT/B Generator	EVERFINE	EMS61000-4A-V2	1012005	May 13, 2020	May 12, 2021	1 year
4	Universal radio communication tester	R&S	CMU200	1100.008.02	May 13, 2020	May 12, 2021	1 year
5	Wideband Radio Communication Tester Specifications	R&S	CMW500	148500	May 13, 2020	May 12, 2021	1 year

## 2.4.7 INJECTION CURRENT

Item	Kind of Equipment	Manufacturer	Type No.	Serial No.	Last calibration	Calibrated until	Calibration period
1	Signal Generator	R&S	SML03	100954	May 13, 2020	May 12, 2021	1 year
2	Power Amplifier	TESEQ	CBA 230M-080	T44376	May 13, 2020	May 12, 2021	1 year
3	Coupling and Decoupling Network	TESEQ	CDN M016	38722	Aug. 28, 2019	Aug. 27, 2020	1 year
4	EM Clamp	FCC	F-203I-23MM	504	May 13, 2020	May 12, 2021	1 year
5	Attenuator	TESEQ	ATN 6075	38411	N/A	N/A	N/A
6	RF Cable	TESEQ	RF Cable	N/A	N/A	N/A	N/A
7	Unversal radio communication tester	R&S	CMU200	1100.008.02	May 13, 2020	May 12, 2021	1 year
8	Audio Power Amplifier	Brüel & Kjær	4602B	2185667	May 13, 2020	May 12, 2021	1 year
9	Mouth Simulator	Brüel & Kjær	2669	2143265	May 13, 2020	May 12, 2021	1 year
10	Sound Calibrator	Brüel & Kjær	4185	2194825	May 13, 2020	May 12, 2021	1 year
11	1/2" Pressure-field Microphone	Brüel & Kjær	735	2641678	May 13, 2020	May 12, 2021	1 year
12	Audio Analyzer	R&S	UPV	100419	May 13, 2020	May 12, 2021	1 year
13	Ear Simulator for Telephonometry	Brüel & Kjær	4185	2553612	May 13, 2020	May 12, 2021	1 year
14	Telephone Test Head	Brüel & Kjær	4185	2631728	May 13, 2020	May 12, 2021	1 year
15	Wideband Radio Communication Tester Specifications	R&S	CMW500	148500	May 13, 2020	May 12, 2021	1 year



### 3. EMC EMISSION TEST

#### 3.1 CONDUCTED EMISSION MEASUREMENT

##### 3.1.1 POWER LINE CONDUCTED EMISSION (Frequency Range 150KHz-30MHz)

**Table A.10 – Requirements for asymmetric mode conducted emissions from Class A equipment**

Applicable to					
1. wired network ports (3.1.30) 2. optical fibre ports (3.1.24) with metallic shield or tension members 3. antenna ports (3.1.3)					
Table clause	Frequency range MHz	Coupling device (see Table A.7)	Detector type / bandwidth	Class A voltage limits dB(μV)	Class A current limits dB(μA)
A10.1	0,15 – 0,5	AAN	Quasi Peak / 9 kHz	97 – 87	n/a
	0,5 – 30			87	
	0,15 – 0,5	AAN	Average / 9 kHz	84 – 74	
	0,5 – 30			74	
A10.2	0,15 – 0,5	CVP and current probe	Quasi Peak / 9 kHz	97 – 87	53 – 43
	0,5 – 30			87	43
	0,15 – 0,5	CVP and current probe	Average / 9 kHz	84 – 74	40 – 30
	0,5 – 30			74	30
A10.3	0,15 – 0,5	Current Probe	Quasi Peak / 9 kHz	n/a	53 – 43
	0,5 – 30				43
	0,15 – 0,5	Current Probe	Average / 9 kHz		40 – 30
	0,5 – 30				30
The choice of coupling device and measurement procedure is defined in Annex C.  AC mains ports that also have the function of a wired network port shall meet the limits given in Table A.8.  The test shall cover the entire frequency range.  The application of the voltage and/or current limits is dependent on the measurement procedure used. Refer to Table C.1 for applicability.  Testing is required at only one EUT supply voltage and frequency.  Applicable to ports listed above and intended to connect to cables longer than 3 m.					

**Table A.11 – Requirements for asymmetric mode conducted emissions from Class B equipment**

<b>Applicable to</b>					
1. wired network ports (3.1.30) 2. optical fibre ports (3.1.24) with metallic shield or tension members 3. broadcast receiver tuner ports (3.1.8) 4. antenna ports (3.1.3)					
<b>Table clause</b>	<b>Frequency range MHz</b>	<b>Coupling device (see Table A.7)</b>	<b>Detector type / bandwidth</b>	<b>Class B voltage limits dB(μV)</b>	<b>Class B current limits dB(μA)</b>
A11.1	0,15 – 0,5	AAN	Quasi Peak / 9 kHz	84 – 74	n/a
	0,5 – 30			74	
	0,15 – 0,5	AAN	Average / 9 kHz	74 – 64	
	0,5 – 30			64	
A11.2	0,15 – 0,5	CVP and current probe	Quasi Peak / 9 kHz	84 – 74	40 – 30
	0,5 – 30			74	30
	0,15 – 0,5	CVP and current probe	Average / 9 kHz	74 – 64	30 – 20
	0,5 – 30			64	20
A11.3	0,15 – 0,5	Current Probe	Quasi Peak / 9 kHz	n/a	40 – 30
	0,5 – 30				30
	0,15 – 0,5	Current Probe	Average / 9 kHz		30 – 20
	0,5 – 30				20

The choice of coupling device and measurement procedure is defined in Annex C.

Screened ports including TV broadcast receiver tuner ports are tested with a common-mode impedance of 150 Ω. This is typically accomplished with the screen terminated by 150 Ω to earth.

AC mains ports that also have the function of a wired network port shall meet the limits given in Table A.9.

The test shall cover the entire frequency range.

The application of the voltage and/or current limits is dependent on the measurement procedure used. Refer to Table C.1 for applicability.

Testing is required at only one EUT supply voltage and frequency.

Applicable to ports listed above and intended to connect to cables longer than 3 m.

**Table A.12 – Requirements for conducted differential voltage emissions from Class B equipment**

Applicable to						
1. TV broadcast receiver tuner ports (3.1.8) with an accessible connector						
2. RF modulator output ports (3.1.27)						
3. FM broadcast receiver tuner ports (3.1.8) with an accessible connector						
Table clause	Frequency range MHz	Detector type/ bandwidth	Class B limits dB(μV) 75 Ω			Applicability
			Other	Local Oscillator Fundamental	Local Oscillator Harmonics	
A12.1	30 – 950	For frequencies ≤1 GHz	46	46	46	See a)
	950 – 2 150		46	54	54	
A12.2	950 – 2 150	Quasi Peak/ 120 kHz	46	54	54	See b)
A12.3	30 – 300		For frequencies ≥1 GHz	46	54	50
	300 – 1 000	52				
A12.4	30 – 300	Peak/ 1 MHz	46	66	59	See d)
	300 – 1 000				52	
A12.5	30 – 950	Peak/ 1 MHz	46	76	46	See e)
	950 – 2 150			n/a	54	

- a) Television receivers (analogue or digital), video recorders and PC TV broadcast receiver tuner cards working in channels between 30 MHz and 1 GHz, and digital audio receivers.
- b) Tuner units (not the LNB) for satellite signal reception.
- c) Frequency modulation audio receivers and PC tuner cards.
- d) Frequency modulation car radios.
- e) Applicable to EUTs with RF modulator output ports (for example DVD equipment, video recorders, camcorders and decoders etc.) designed to connect to TV broadcast receiver tuner ports.

Testing is required at only one EUT supply voltage and frequency.

The term 'other' refers to all emissions other than the fundamental and the harmonics of the local oscillator.

The test shall be performed with the device operating at each reception channel.

The test shall cover the entire frequency range.

The following table is the setting of the receiver

Receiver Parameters	Setting
Attenuation	10 dB
Start Frequency	0.15 MHz
Stop Frequency	30 MHz
IF Bandwidth	9 kHz



### 3.1.2 TEST PROCEDURE

- The EUT was placed 0.8 meters from the horizontal ground plane with EUT being connected to the power mains through a line impedance stabilization network (LISN). All other support equipments powered from additional LISN(s). The LISN provide 50 Ohm/ 50uH of coupling impedance for the measuring instrument.
- Interconnecting cables that hang closer than 40 cm to the ground plane shall be folded back and forth in the center forming a bundle 30 to 40 cm long.
- I/O cables that are not connected to a peripheral shall be bundled in the center. The end of the cable may be terminated, if required, using the correct terminating impedance. The overall length shall not exceed 1 m.
- LISN at least 80 cm from nearest part of EUT chassis.
- For the actual test configuration, please refer to the related Item –EUT Test Photos.

### 3.1.3 TEST SETUP

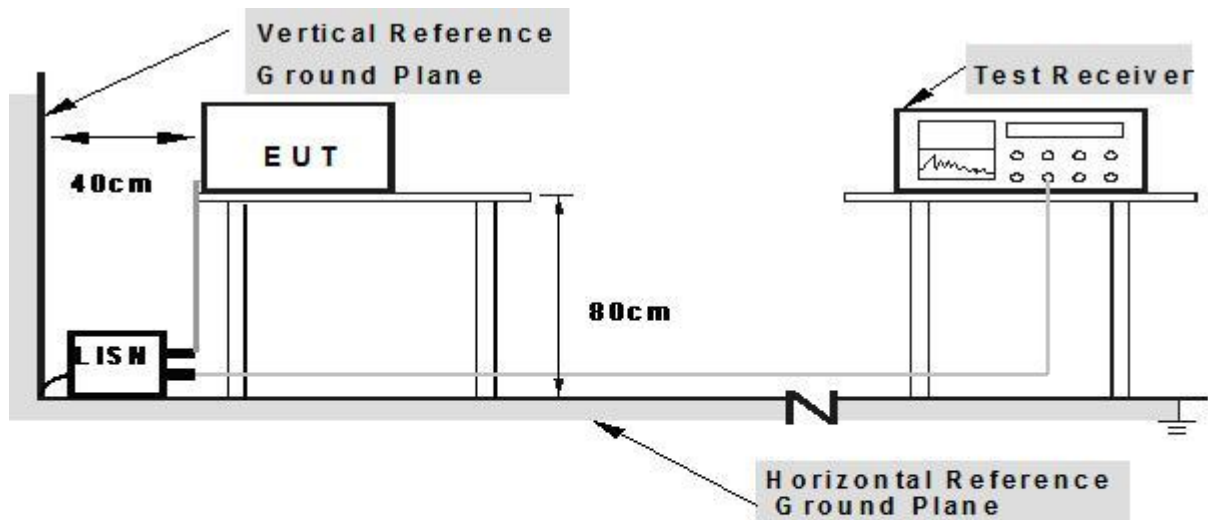

**Note: 1. Support units were connected to second LISN.**

**2. Both of LISNs (AMN) are 80 cm from EUT and at least 80 cm from other units and other metal planes**

### 3.1.4 EUT OPERATING CONDITIONS

The EUT tested system was configured as the statements of 2.2 Unless otherwise a special operating condition is specified in the follows during the testing.



3.1.5 TEST RESULTS

EUT :	Computer Multimedia Speaker	Model Name. :	R23BT
Temperature :	24 °C	Relative Humidity :	45%
Pressure :	1010hPa	Phase :	L
Test Voltage :	AC 230V/50Hz	Test Mode :	Mode 1

Frequency (MHz)	Meter Reading (dBμV)	Factor (dB)	Emission Level (dBμV)	Limits (dBμV)	Margin (dB)	Remark
0.2459	32.07	9.55	41.62	61.89	-20.27	QP
0.2459	17.65	9.55	27.20	51.89	-24.68	AVG
0.3019	27.44	9.54	36.98	60.19	-23.21	QP
0.3019	21.19	9.54	30.73	50.19	-19.46	AVG
0.5180	33.36	9.55	42.91	56.00	-13.09	QP
0.5180	27.87	9.55	37.42	46.00	-8.58	AVG
1.1419	22.93	9.56	32.49	56.00	-23.51	QP
1.1419	18.68	9.56	28.24	46.00	-17.76	AVG
1.8420	22.95	9.58	32.53	56.00	-23.47	QP
1.8420	18.22	9.58	27.80	46.00	-18.20	AVG
2.4820	23.10	9.58	32.68	56.00	-23.32	QP
2.4820	15.61	9.58	25.19	46.00	-20.81	AVG

Remark:

1. All readings are Quasi-Peak and Average values.
2. Factor = Insertion Loss + Cable Loss.

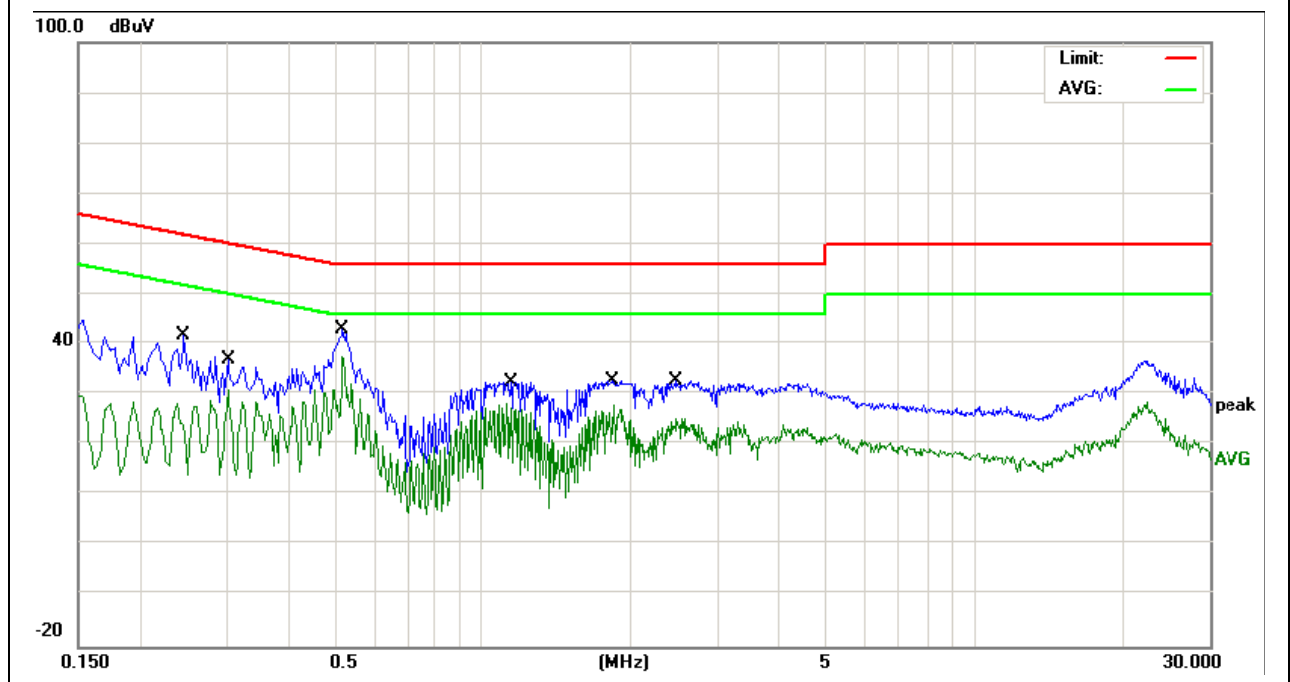

EUT :	Computer Multimedia Speaker	Model Name. :	R23BT
Temperature :	24 °C	Relative Humidity :	45%
Pressure :	1010hPa	Phase :	N
Test Voltage :	AC 230V/50Hz	Test Mode :	Mode 1

Frequency (MHz)	Meter Reading (dBμV)	Factor (dB)	Emission Level (dBμV)	Limits (dBμV)	Margin (dB)	Remark
0.1660	34.45	9.55	44.00	65.15	-21.15	QP
0.1660	18.30	9.55	27.85	55.15	-27.30	AVG
0.2020	32.01	9.54	41.55	63.52	-21.97	QP
0.2020	18.84	9.54	28.38	53.52	-15.14	AVG
0.5260	32.49	9.54	42.03	56.00	-13.97	QP
0.5260	27.98	9.54	37.52	46.00	-8.48	AVG
1.1220	23.83	9.55	33.38	56.00	-22.62	QP
1.1220	17.92	9.55	27.47	46.00	-18.53	AVG
1.8220	23.82	9.57	33.39	56.00	-22.61	QP
1.8220	15.13	9.57	24.70	46.00	-21.30	AVG
4.2698	24.96	9.61	34.57	56.00	-21.43	QP
4.2698	16.63	9.61	26.24	46.00	-19.76	AVG

Remark:

1. All readings are Quasi-Peak and Average values.
2. Factor = Insertion Loss + Cable Loss.

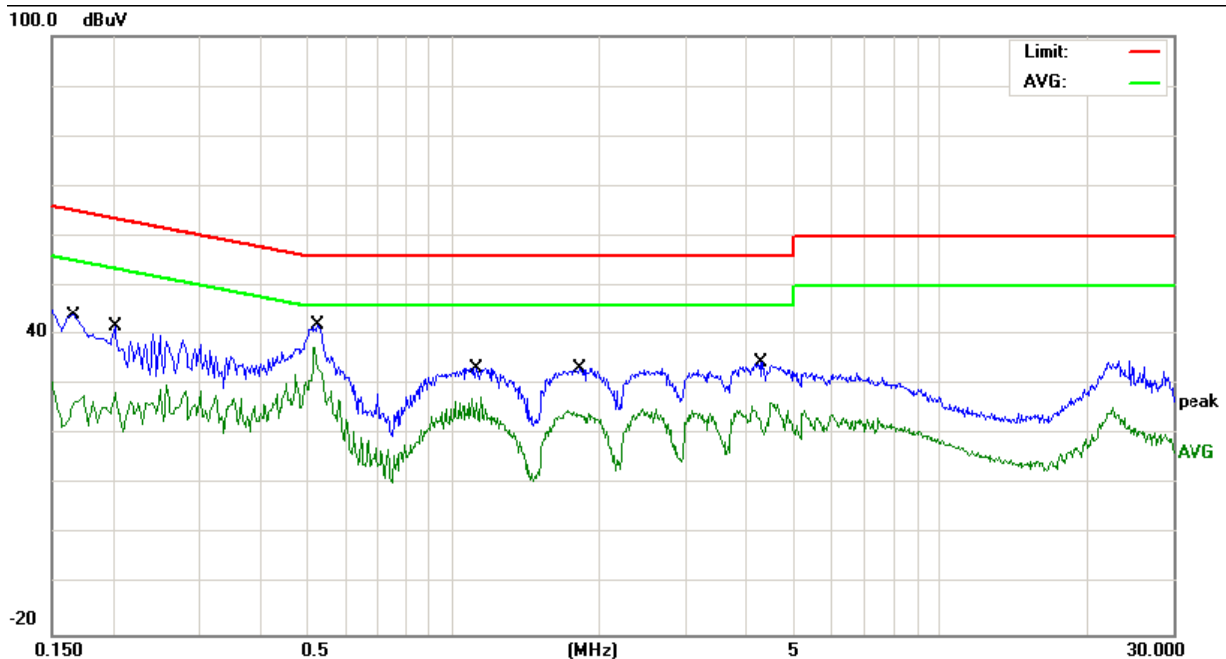

Note: The test modes were carried out for all operation modes. The worst test mode for test data was showed in the report.

### 3.2 RADIATED EMISSION MEASUREMENT

#### 3.2.1 LIMITS OF RADIATED EMISSION MEASUREMENT (Below 1000MHz)

**Table A.2 – Requirements for radiated emissions at frequencies up to 1 GHz for Class A equipment**

Table clause	Frequency range MHz	Measurement		Class A limits dB(μV/m)
		Distance m	Detector type/ bandwidth	OATS/SAC (see Table A.1)
A2.1	30 – 230	10	Quasi Peak / 120 kHz	40
	230 – 1 000			47
A2.2	30 – 230	3		50
	230 – 1 000			57

Apply only A2.1 or A2.2 across the entire frequency range.

**Table A.4 – Requirements for radiated emissions at frequencies up to 1 GHz for Class B equipment**

Table clause	Frequency range MHz	Measurement		Class B limits dB(μV/m)
		Distance m	Detector type/ bandwidth	OATS/SAC (see Table A.1)
A4.1	30 – 230	10	Quasi Peak / 120 kHz	30
	230 – 1 000			37
A4.2	30 – 230	3		40
	230 – 1 000			47

Apply only table clause A4.1 or A4.2 across the entire frequency range.

**Table A.6 – Requirements for radiated emissions from FM receivers**

Table clause	Frequency range MHz	Measurement		Class B limit dB(μV/m)		
		Distance m	Detector type/ bandwidth	Fundamental	Harmonics	
				OATS/SAC (see Table A.1)	OATS/SAC (see Table A.1)	
A6.1	30 – 230	10	Quasi peak/ 120 kHz	50	42	
	230 – 300				42	
	300 – 1 000				46	
A6.2	30 – 230	3		Quasi peak/ 120 kHz	60	52
	230 – 300					52
	300 – 1 000					56

Apply only A.6.1 or A.6.2 across the entire frequency range.

These relaxed limits apply only to emissions at the fundamental and harmonic frequencies of the local oscillator. Signals at all other frequencies shall be compliant with the limits given in Table A.4.



### 3.2.2 LIMITS OF RADIATED EMISSION MEASUREMENT (Above 1000MHz)

**Table A.3 – Requirements for radiated emissions at frequencies above 1 GHz for Class A equipment**

Table clause	Frequency range MHz	Measurement		Class A limits dB(μV/m)
		Distance m	Detector type/ bandwidth	FSOATS (see Table A.1)
A3.1	1 000 – 3 000	3	Average / 1 MHz	56
	3 000 – 6 000			60
A3.2	1 000 – 3 000		Peak / 1 MHz	76
	3 000 – 6 000			80

Apply A3.1 and A3.2 across the frequency range from 1 000 MHz to the highest required frequency of measurement derived from Table 1.

**Table A.5 – Requirements for radiated emissions at frequencies above 1 GHz for Class B equipment**

Table clause	Frequency range MHz	Measurement		Class B limits dB(μV/m)
		Distance m	Detector type/ bandwidth	FSOATS (see Table A.1)
A5.1	1 000 – 3 000	3	Average/ 1 MHz	50
	3 000 – 6 000			54
A5.2	1 000 – 3 000		Peak/ 1 MHz	70
	3 000 – 6 000			74

Apply A5.1 and A5.2 across the frequency range from 1 000 MHz to the highest required frequency of measurement derived from Table 1.

**Notes:**

- (1) The limit for radiated test was performed according to as following: CISPR 32.
- (2) The tighter limit applies at the band edges.
- (3) Emission level (dBμV/m)=20log Emission level (uV/m).

### 3.2.3 TEST PROCEDURE

- a. The measuring distance of at 3 m shall be used for measurements at frequency up to 1GHz. For frequencies above 1GHz, any suitable measuring distance may be used.
- b. The EUT was placed on the top of a rotating table 0.8 meters above the ground at a 10 meter open area test site. The table was rotated 360 degrees to determine the position of the highest radiation.
- c. The height of the equipment or of the substitution antenna shall be 0.8 m; the height of the test antenna shall vary between 1 m to 4 m. Both horizontal and vertical polarizations of the antenna are set to make the measurement.
- d. The initial step in collecting conducted emission data is a spectrum analyzer peak detector mode pre-scanning the measurement frequency range. Significant peaks are then marked and then Quasi Peak detector mode re-measured.
- e. If the Peak Mode measured value compliance with and lower than Quasi Peak Mode Limit, the EUT shall be deemed to meet QP Limits and then no additional QP Mode measurement performed.
- f. For the actual test configuration, please refer to the related Item –EUT Test Photos.



3.2.4 TEST SETUP

(A) Radiated Emission Test Set-Up Frequency Below 1 GHz

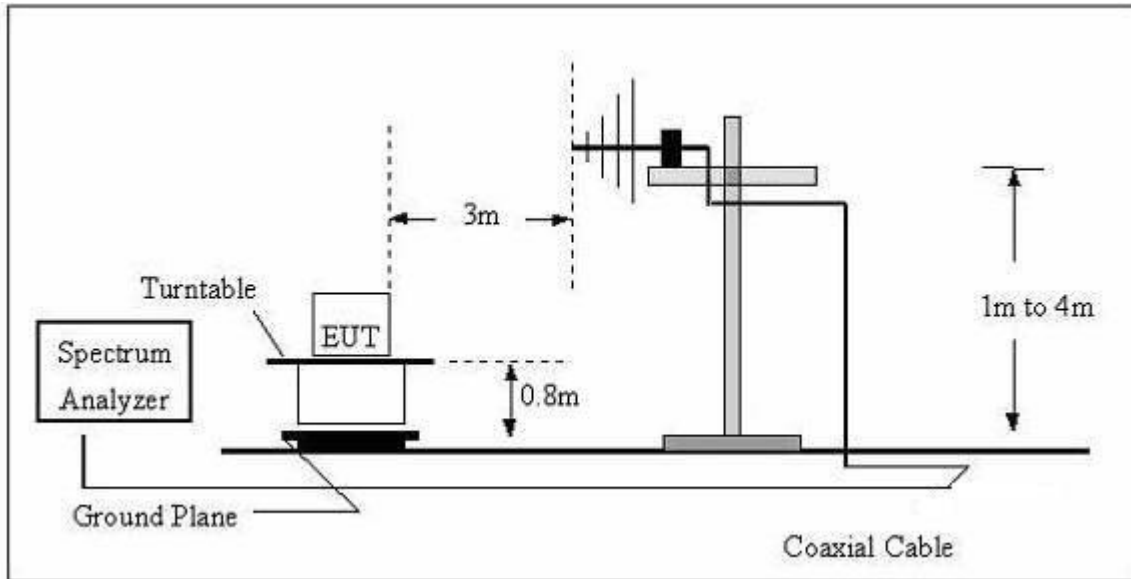

(B) Radiated Emission Test Set-Up Frequency Above 1GHz

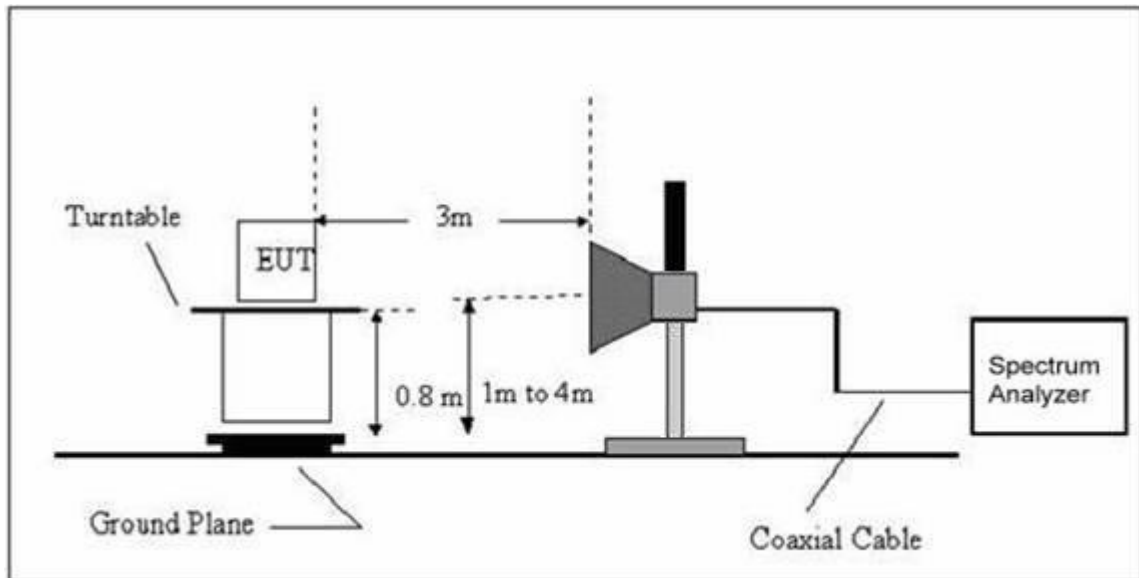

3.2.5 EUT OPERATING CONDITIONS

The EUT tested system was configured as the statements of 2.2 Unless otherwise a special operating condition is specified in the follows during the testing.

3.2.6 TEST RESULTS (30-1000MHz)

EUT :	Computer Multimedia Speaker	Model Name :	R23BT
Temperature :	25 °C	Relative Humidity :	55%
Pressure :	1010 hPa	Polarization :	Horizontal
Test Power :	AC 230V/50Hz	Test Mode :	Mode 1

Frequency (MHz)	Meter Reading (dBμV)	Factor (dB)	Emission Level (dBμV/m)	Limits (dBμV/m)	Margin (dB)	Remark
30.2109	6.56	18.72	25.28	40.00	-14.72	QP
101.6443	13.13	11.08	24.21	40.00	-15.79	QP
543.2740	7.35	21.95	29.30	47.00	-17.70	QP
729.3582	6.77	25.10	31.87	47.00	-15.13	QP
842.1295	7.74	26.16	33.90	47.00	-13.10	QP
948.7608	6.80	28.35	35.15	47.00	-11.85	QP

Remark:

1. Factor = Antenna Factor + Cable Loss – Pre-amplifier.

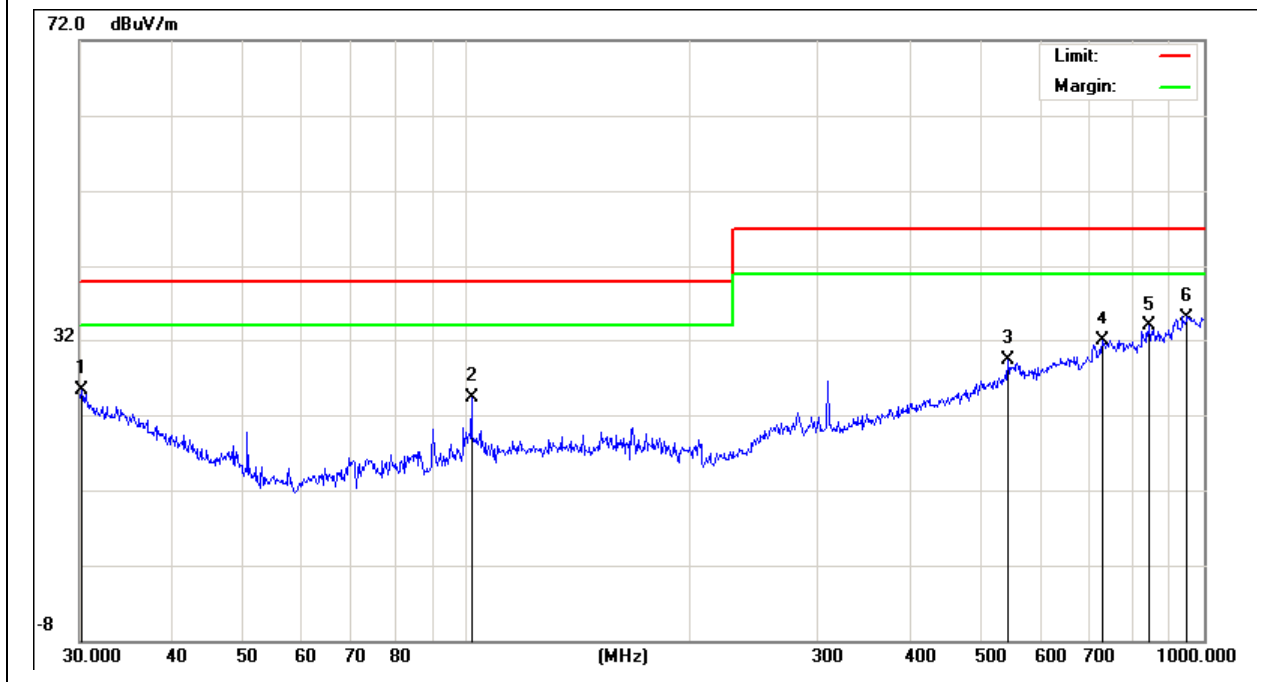

EUT :	Computer Multimedia Speaker	Model Name :	R23BT
Temperature :	23°C	Relative Humidity :	55%
Pressure :	1010 hPa	Polarization :	Vertical
Test Power :	AC 230V/50Hz	Test Mode :	Mode 1

Frequency (MHz)	Meter Reading (dBμV)	Factor (dB)	Emission Level (dBμV/m)	Limits (dBμV/m)	Margin (dB)	Remark
30.0000	14.97	18.84	33.81	40.00	-6.19	QP
39.0245	16.74	14.46	31.20	40.00	-8.80	QP
75.1822	19.73	7.25	26.98	40.00	-13.02	QP
739.6604	6.50	25.11	31.61	47.00	-15.39	QP
900.1473	8.88	26.12	35.00	47.00	-12.00	QP
955.4380	6.77	28.41	35.18	47.00	-11.82	QP

Remark:

1. Factor = Antenna Factor + Cable Loss – Pre-amplifier.

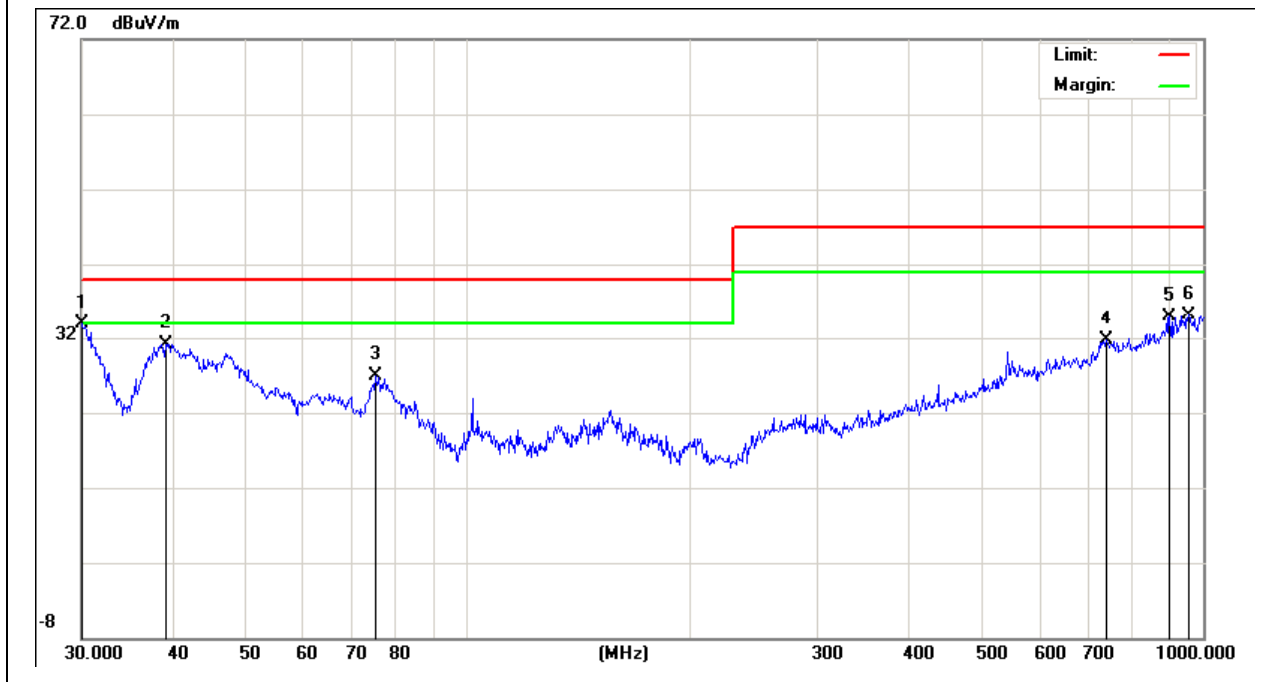

Note: The test modes were carried out for all operation modes. The worst test mode for test data was showed in the report.

3.2.7 TEST RESULTS(1000-6000MHz)

EUT :	Computer Multimedia Speaker	Model Name :	R23BT
Temperature :	23 °C	Relative Humidity :	55%
Pressure :	1010 hPa	Test Mode :	Mode 1
Test Power :	AC 230V/50Hz		

Polar (H/V)	Frequency	Meter Reading	Factor	Emission Level	Limits	Margin	Remark
	(MHz)	(dBµV/m)	(dB)	(dBµV/m)	(dBµV/m)	(dB)	
V	1312.500	40.80	2.21	43.01	70.00	-26.99	peak
V	2100.000	39.24	6.33	45.57	70.00	-24.43	peak
V	3950.000	38.02	10.89	48.91	74.00	-25.09	peak
V	4400.000	36.62	12.38	49.00	74.00	-25.00	peak
V	4825.000	36.06	13.63	49.69	74.00	-24.31	peak
V	5562.500	35.55	13.44	48.99	74.00	-25.01	peak
H	1275.000	40.88	2.14	43.02	70.00	-26.98	peak
H	2112.500	38.66	6.22	44.88	70.00	-25.12	peak
H	2962.500	39.03	6.27	45.30	70.00	-24.70	peak
H	4237.500	37.55	11.56	49.11	74.00	-24.89	peak
H	4837.500	35.57	13.61	49.18	74.00	-24.82	peak
H	5587.500	35.71	13.49	49.20	74.00	-24.80	peak

**Remark:**

Absolute Level= ReadingLevel+ Factor, Margin= Absolute Level - Limit

Note: The test modes were carried out for all operation modes. The worst test mode for test data was showed in the report.



### 3.3 HARMONICS CURRENT

#### 3.3.1 LIMITS OF HARMONICS CURRENT

Table 1 – Limits for Class A equipment

Harmonic order (n)	Maximum permissible harmonic current (A)
Odd harmonics	
3	2.3
5	1.14
7	0.77
9	0.4
11	0.33
13	0.21
$15 \leq n \leq 39$	$0.15 * (15/n)$
Even harmonics	
2	1.08
4	0.43
6	0.30
$8 \leq n \leq 40$	$0.23 * (8/n)$

Note: Reference standard of the table above: EN61000-3-2.

### 3.3.2 TEST PROCEDURE

a. The EUT was placed on the top of a wooden table 0.8 meters above the ground and operated to produce the maximum harmonic components under normal operating conditions.

b. The classification of EUT is according to section 5 of EN 61000-3-2. The EUT is classified as follows:

Class A: Balanced three-phase equipment, Household appliances excluding equipment as Class D, Tools excluding portable tools, Dimmers for incandescent lamps, audio equipment, equipment not specified in one of the three other classes.

Class B: Portable tools. Portable tools.; Arc welding equipment which is not professional equipment.

Class C: Lighting equipment.

Class D: Equipment having a specified power less than or equal to 600W of the following types: Personal computers and personal computer monitors and television receivers.

c. The correspondent test program of test instrument to measure the current harmonics emanated from EUT is chosen. The measure time shall be not less than the time necessary for the EUT to be exercised.

### 3.3.3 EUT OPERATING CONDITIONS

The EUT tested system was configured as the statements of **2.3** Unless otherwise a special operating condition is specified in the follows during the testing.

### 3.3.4 TEST SETUP

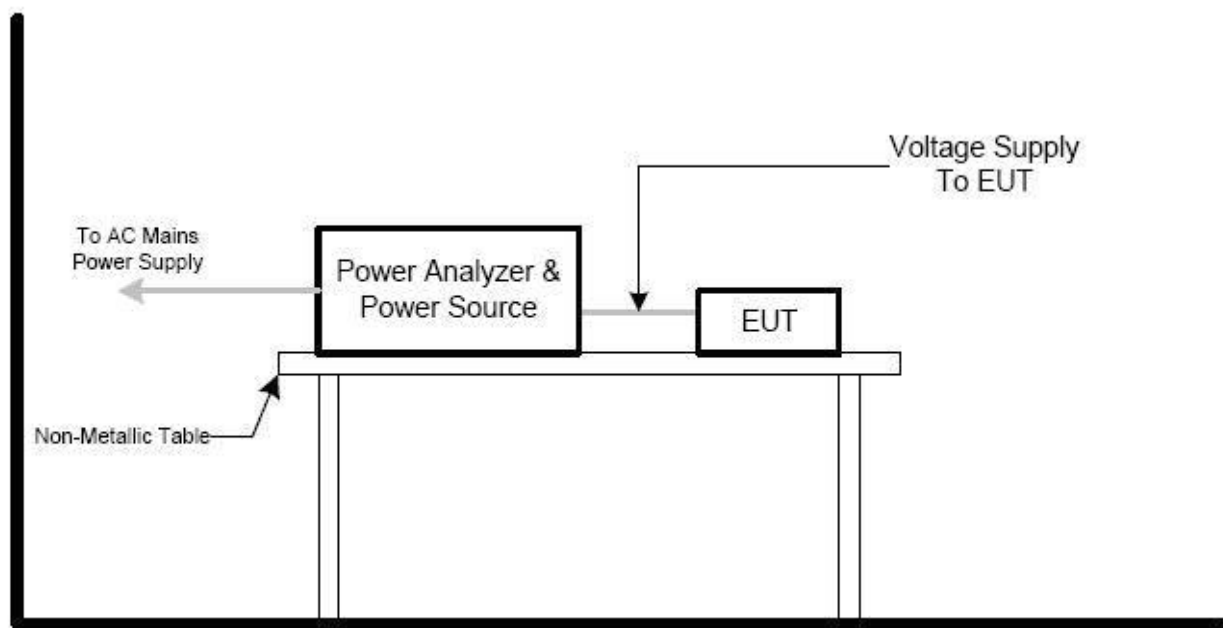

## 3.3.5 TEST RESULTS

EUT:	Computer Multimedia Speaker	Model Name:	R23BT
Temperature:	20°C	Relative Humidity:	49%
Pressure:	1012hPa	Test duration:	150s
Classification:	Class A	Test Power:	N/A
Test Mode:	N/A		

Note: Not applicable

3.4 VOLTAGE FLUCTUATION AND FLICKERS

3.4.1 LIMITS OF VOLTAGE FLUCTUATION AND FLICKERS

Test items	Limits(EN61000-3-3)	Descriptions
$P_{st}$	$\leq 1.0, T_p=10min$	short-term flicker indicator
$P_{lt}$	$\leq 0.65, T_p=2h$	long-term flicker indicator
$d_c$	$\leq 3.3\%$	relative steady-state voltage change
$d_{max}$	$\leq 4\%$ (or $6\%$ <sup>Note(1)</sup> , $7\%$ <sup>Note(2)</sup> )	maximum relative voltage change:
$d_{(t)}$	$\leq 3.3\%$ , more than 500ms	relative voltage change characteristic

Note:

1. 6 % for equipment which is:
  - a. switched manually, or
  - b. switched automatically more frequently than twice per day, and also has either a delayed restart (the delay being not less than a few tens of seconds), or manual restart, after a power supply interruption.
2. 7 % for equipment which is
  - a. attended whilst in use (for example: hair dryers, vacuum cleaners, kitchen equipment such as mixers, garden equipment such as lawn mowers, portable tools such as electric drills), or
  - b. switched on automatically, or is intended to be switched on manually, no more than twice per day, and also has either a delayed restart (the delay being not less than a few tens of seconds) or manual restart, after a power supply interruption.

3.4.2 TEST PROCEDURE

a. Harmonic Current Test:

Test was performed according to the procedures specified in Sub-clause 6.2 of IEC/EN 61000-3-2 depend on which standard adopted for compliance measurement.

b. Fluctuation and Flickers Test:

Tests was performed according to the Test Conditions/Assessment of Voltage Fluctuations specified in Clause 6.0/4.0 of IEC/EN 61000-3-3 depend on which standard adopted for compliance measurement.

c. All types of harmonic current and/or voltage fluctuation in this report are assessed by direct measurement using flicker-meter.

3.4.3 EUT OPERATING CONDITIONS

The EUT tested system was configured as the statements of 2.3 Unless otherwise a special operating condition is specified in the follows during the testing.



### 3.4.4 TEST SETUP

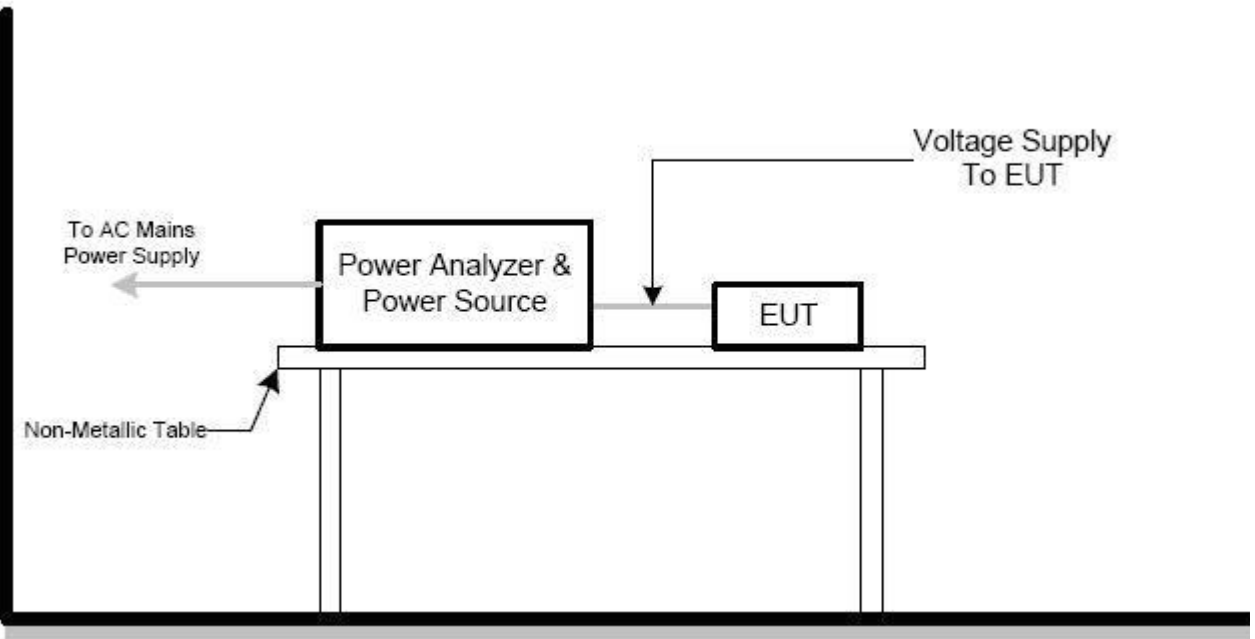

## 3.4.5 TEST RESULTS

EUT :	Computer Multimedia Speaker	Model Name :	R23BT
Temperature :	25 °C	Relative Humidity :	45%
Pressure :	1010 hPa	Test Power :	AC 230V/50Hz
Test Mode	Mode 1		

	EUT values	Limit	Result
Pst	0.028	1.00	PASS
Plt	0.028	0.65	PASS
dc [%]	0.000	3.30	PASS
dmax [%]	0.075	4.00	PASS
dt [%]	0.000	0.50	PASS

**4. EMC IMMUNITY TEST**

**4.1 GENERAL PERFORMANCE CRITERIA**

**4.1.1 PERFORMANCE CRITERIA**

According to **EN 55035** standard, the general performance criteria as following:

<p><b>Criterion A</b></p>	<p>The equipment shall continue to operate as intended without operator intervention. No degradation of performance or loss of function is allowed below a performance level specified by the manufacturer when the equipment is used as intended.</p> <p>The performance level may be replaced by a permissible loss of performance. If the minimum performance level or the permissible performance loss is not specified by the manufacturer, then either of these may be derived from the product description and documentation, and by what the user may reasonably expect from the equipment if used as intended.</p>
<p><b>Criterion B</b></p>	<p>After the test, the equipment shall continue to operate as intended without operator intervention. No degradation of performance or loss of function is allowed, after the application of the phenomena below a performance level specified by the manufacturer, when the equipment is used as intended.</p> <p>The performance level may be replaced by a permissible loss of performance. During the test, degradation of performance is allowed. However, no change of operating state or stored data is allowed to persist after the test.</p>
<p><b>Criterion C</b></p>	<p>Loss of function is allowed, provided the function is self-recoverable, or can be restored by the operation of the controls by the user in accordance with the manufacturer's instructions.</p> <p>Functions, and/or information stored in non-volatile memory, or protected by a battery backup, shall not be lost.</p>

According to **EN 301489-17** standard, the general performance criteria as following:

Criteria	During the test	After the test
A	Shall operate as intended. (see note 1). Shall be no loss of function. Shall be no unintentional transmissions	Shall operate as intended. Shall be no degradation of performance (see note 3). Shall be no loss of function. Shall be no loss of stored data or user programmable functions
B	May show loss of function (one or more). May show degradation of performance (see note 2). Shall be no unintentional transmissions.	Functions shall be self-recoverable. Shall operate as intended after recovering. Shall be no degradation of performance (see note 3). Shall be no loss of stored data or user programmable functions.
C	May be loss of function (one or more)	Functions shall be recoverable by the operator. Shall operate as intended after recovering. Shall be no degradation of performance (see note 3).

NOTE 1: Operate as intended during the test allows a level of degradation not below a minimum performance level specified by the manufacturer for the use of the apparatus as intended. In some cases the specified minimum performance level may be replaced by a permissible degradation of performance. If the minimum performance level or the permissible performance degradation is not specified by the manufacturer then either of these may be derived from the product description and documentation (including leaflets and advertising) and what the user may reasonably expect from the apparatus if used as intended.

NOTE 2: Degradation of performance during the test is understood as a degradation to a level not below a minimum performance level specified by the manufacturer for the use of the apparatus as intended. In some cases the specified minimum performance level may be replaced by a permissible degradation of performance.

If the minimum performance level or the permissible performance degradation is not specified by the manufacturer then either of these may be derived from the product description and documentation (including leaflets and advertising) and what the user may reasonably expect from the apparatus if used as intended.

NOTE 3: No degradation of performance after the test is understood as no degradation below a minimum performance level specified by the manufacturer for the use of the apparatus as intended. In some cases the specified minimum performance level may be replaced by a permissible degradation of performance. After the test no change of actual operating data or user retrievable data is allowed. If the minimum performance level or the permissible performance degradation is not specified by the manufacturer then either of these may be derived from the product description and documentation (including leaflets and advertising) and what the user may reasonably expect from the apparatus if used as intended.



**PERFORMANCE FOR TT**

The performance criteria B shall apply, except for voltage dips of 100 ms and voltage interruptions of 5 000 ms duration, for which performance criteria C shall apply. Tests shall be repeated with the EUT in standby mode (if applicable) to ensure that unintentional transmission does not occur. In systems using acknowledgement signals, it is recognized that an acknowledgement (ACK) or not-acknowledgement (NACK) transmission may occur, and steps should be taken to ensure that any transmission resulting from the application of the test is correctly interpreted.

**PERFORMANCE FOR TR**

The performance criteria B shall apply, except for voltage dips of 100 ms and voltage interruptions of 5 000 ms duration for which performance criteria C shall apply. Where the EUT is a transceiver, under no circumstances, shall the transmitter operate unintentionally during the test. In systems using acknowledgement signals, it is recognized that an ACK or NACK transmission may occur, and steps should be taken to ensure that any transmission resulting from the application of the test is correctly interpreted.

**PERFORMANCE FOR CT**

The performance criteria A shall apply. Tests shall be repeated with the EUT in standby mode (if applicable) to ensure that unintentional transmission does not occur. In systems using acknowledgement signals, it is recognized that an Acknowledgement (ACK) or Not Acknowledgement (NACK) transmission may occur, and steps should be taken to ensure that any transmission resulting from the application of the test is correctly interpreted.

**PERFORMANCE FOR CR**

The performance criteria A shall apply. Where the EUT is a transceiver, under no circumstances, shall the transmitter operate unintentionally during the test. In systems using acknowledgement signals, it is recognized that an ACK or NACK transmission may occur, and steps should be taken to ensure that any transmission resulting from the application of the test is correctly interpreted.

**4.2 GENERAL PERFORMANCE CRITERIA TEST SETUP**

The EUT tested system was configured as the statements of **2.2** Unless otherwise a special operating condition is specified in the follows during the testing.

4.3 ESD TESTING

4.3.1 TEST SPECIFICATION

Basic Standard:	IEC/EN 61000-4-2
Discharge Impedance:	330 ohm / 150 pF
Required Performance	B
Discharge Voltage:	Air Discharge : 2kV/4kV/8kV Contact Discharge : 2kV/4kV (Direct/Indirect)
Polarity:	Positive & Negative
Number of Discharge:	Air Discharge: min. 20 times at each test point Contact Discharge: min. 200 times in total
Discharge Mode:	A/C Discharge
Discharge Period:	1 second minimum

4.3.2 TEST PROCEDURE

The test generator necessary to perform direct and indirect application of discharges to the EUT in the following manner:

a. Indirect application of the discharge:

Vertical Coupling Plane (VCP):

At least 10 single discharges (in the most sensitive polarity) shall be applied to the centre of one vertical edge of the coupling plane. The coupling plane, of dimensions 0,5 m × 0,5 m, is placed parallel to, and positioned at a distance of 0,1 m from, the EUT.

Discharges shall be applied to the coupling plane, with sufficient different positions such that the four faces of the EUT are completely illuminated. One VCP position is considered to illuminate 0,5 m × 0,5 m area of the EUT surface.

Horizontal Coupling Plane (HCP):

Discharge to the HCP shall be made horizontally to the edge of the HCP.

At least 10 single discharges (in the most sensitive polarity) shall be applied at the front edge of each HCP opposite the centre point of each unit (if applicable) of the EUT and 0.1m from the front of the EUT. The long axis of the discharge electrode shall be in the plane of the HCP and perpendicular to its front edge during the discharge.

The discharge electrode shall be in contact with the edge of the HCP before the discharge switch is operated

b. Direct application of discharges to the EUT

The test shall be performed with single discharges. On each pre-selected point at least 10 single discharges (in the most sensitive polarity) shall be applied.

For the time interval between successive single discharges an initial value of 1 s is recommended. Longer intervals may be necessary to determine whether a system failure has occurred.

4.3.3 TEST SETUP

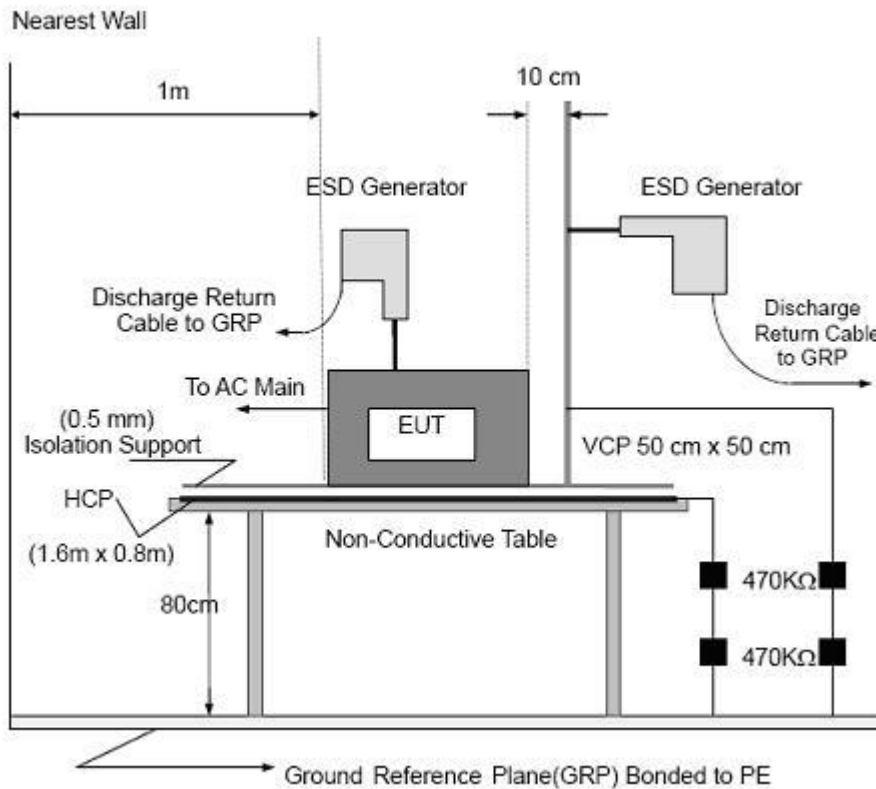

Note:

TABLE-TOP EQUIPMENT

The configuration consisted of a wooden table 0.8 meters high standing on the Ground Reference Plane. The GRP consisted of a sheet of aluminum at least 0.25mm thick, and 2.5 meters square connected to the protective grounding system. A Horizontal Coupling Plane (1.6m x 0.8m) was placed on the table and attached to the GRP by means of a cable with 940k total impedance. The equipment under test, was installed in a representative system as described in section 7 of IEC /EN 61000-4-2, and its cables were placed on the HCP and isolated by an insulating support of 0.5mm thickness. A distance of 1-meter minimum was provided between the EUT and the walls of the laboratory and any other metallic structure.

FLOOR-STANDING EQUIPMENT

The equipment under test was installed in a representative system as described in section 7 of IEC/EN 61000-4-2, and its cables were isolated from the Ground Reference Plane by an insulating support of 0.1-meter thickness. The GRP consisted of a sheet of aluminum that is at least 0.25mm thick, and 2.5meters square connected to the protective grounding system and extended at least 0.5 meters from the EUT on all sides.



4.3.4 TEST RESULTS

EUT :	Computer Multimedia Speaker	Model Name :	R23BT
Temperature :	25 °C	Relative Humidity :	45%
Pressure :	1010 hPa	Test Power :	AC 230V/50Hz
Test Mode	Mode 1/2/3/4		

Mode	Contact Discharge (Indirect)						Criterion	Result	
Test level (kV)	Test Point	2		4		6			
Test Location		+	-	+	-	+			-
HCP	Front	P	P	P	P			<b>B</b>	<b>Complies</b>
	Rear	P	P	P	P				
	Left	P	P	P	P				
	Right	P	P	P	P				
VCP	Front	P	P	P	P				
	Rear	P	P	P	P				
	Left	P	P	P	P				
	Right	P	P	P	P				

Mode 2/3/4

Mode	Air Discharge								Contact Discharge								Observation	Criterion	Result	
Test level (kV)	2		4		8		15		2		4		6		8					
Test Location	+	-	+	-	+	-	+	-	+	-	+	-	+	-	+	-				
GAP	P	P	P	P	P	P												<b>TT,TR</b>	<b>B</b>	<b>Complies</b>
Button	P	P	P	P	P	P														
Audio out	P	P	P	P	P	P														
AUX	P	P	P	P	P	P														
Optical	P	P	P	P	P	P														
USB									P	P	P	P								
Metal									P	P	P	P								



Mode 1

Mode	Air Discharge								Contact Discharge								Criterion	Result
	2		4		8		15		2		4		6		8			
Test level (kV)																		
Test Location	+	-	+	-	+	-	+	-	+	-	+	-	+	-	+	-		
GAP	P	P	P	P	P	P												
Button	P	P	P	P	P	P												
Audio out	P	P	P	P	P	P												
AUX	P	P	P	P	P	P												
Optical	P	P	P	P	P	P												
USB									P	P	P	P						
Metal									P	P	P	P						

Note:

- 1) +/- denotes the Positive/Negative polarity of the output voltage.
- 2) In the table: 'P' represents 'PASS'; 'F' represents 'FAIL'.

4.4 RS TESTING

4.4.1 TEST SPECIFICATION

Basic Standard:	IEC/EN 61000-4-3
Required Performance	A
Frequency Range:	According to EN 301489-1: 80 MHz - 6000 MHz ; According to EN 55035: 80 MHz to 1000 MHz 1800 MHz 2600 MHz 3500 MHz 5000 MHz
Field Strength:	3 V/m
Modulation:	1kHz Sine Wave, 80%, AM Modulation
Frequency Step:	1 % of fundamental
Polarity of Antenna:	Horizontal and Vertical
Test Distance:	3 m
Antenna Height:	1.5 m
Dwell Time:	at least 3 seconds

4.4.2 TEST PROCEDURE

The EUT and support equipment, which are placed on a table that is 0.8 meter above ground and the testing was performed in a fully-anechoic chamber.

The testing distance from antenna to the EUT was 3 meters.

The other condition as following manner:

- a. The field strength level was 3V/m.
- b. The frequency range is swept from 80 MHz to 6000 MHz, 1800 MHz, 2600 MHz, 3500 MHz, 5000 MHz with the signal 80%amplitude modulated with a 1kHz sine wave. The rate of sweep did not exceed  $1.5 \times 10^{-3}$  decade/s. Where the frequency range is swept incrementally, the step size was 1% of fundamental.
- c. Sweep Frequency 900 MHz, with the Duty Cycle:1/8 and Modulation: Pulse 217 Hz(if applicable)
- d. The dwell time at each frequency shall be not less than the time necessary for the EUT to be able to respond.
- e. The test was performed with the EUT exposed to both vertically and horizontally polarized fields on each of the four sides.
- f. For the actual test configuration, please refer to the related Item –EUT Test Photos.

4.4.3 TEST SETUP

Mobile Communication

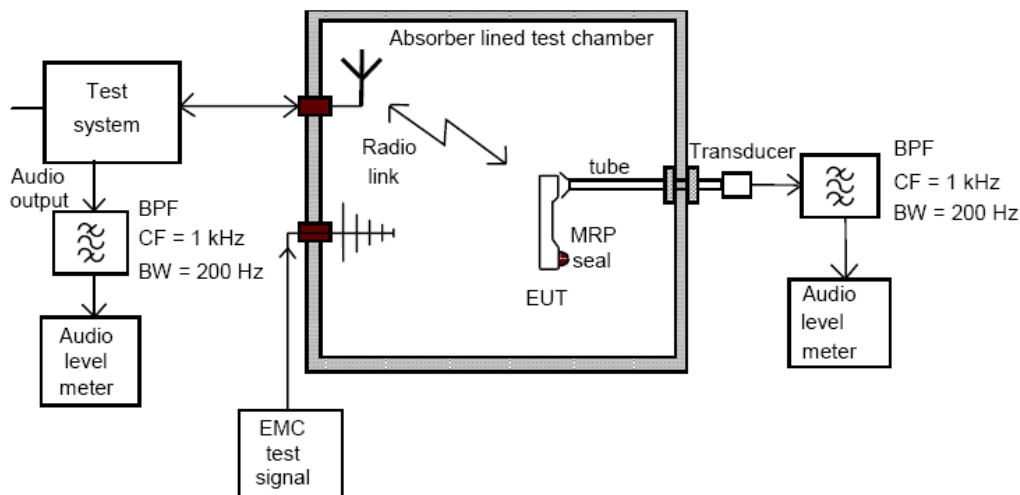

General Communication

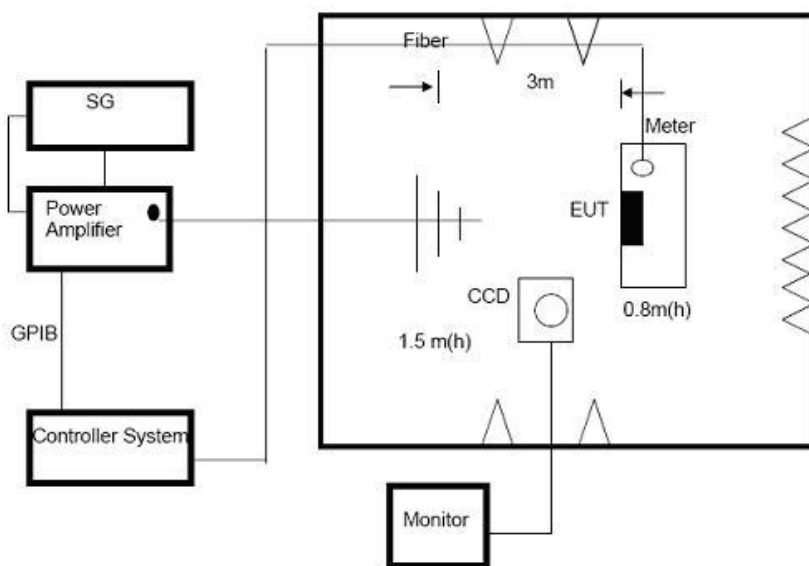

Note:

For the actual test configuration, please refer to the related Item –EUT Test Photos.

TABLE-TOP EQUIPMENT

The EUT installed in a representative system as described in section 7 of IEC/EN 61000-4-3 was placed on a non-conductive table 0.8 meters in height. The system under test was connected to the power and signal wire according to relevant installation instructions.

FLOOR-STANDING EQUIPMENT

The EUT installed in a representative system as described in section 7 of IEC/EN 61000-4-3 was placed on a non-conductive wood support 0.1 meters in height. The system under test was connected to the power and signal wire according to relevant installation instructions.

#### 4.4.4 TEST RESULTS

EUT :	Computer Multimedia Speaker	Model Name :	R23BT
Temperature :	25 °C	Relative Humidity :	45%
Pressure :	1010 hPa	Test Power :	AC 230V/50Hz
Test Mode	Mode 1/2/3/4		

#### TEST RESULT

##### Mode 2/3/4

Frequency Range (MHz)	RF Field Position	R.F. Field Strength	Azimuth	Observation	Perform. Criteria	Results
80~1000	H / V	3 V/m (rms) AM Modulated 1000Hz, 80%	Front	<b>CT,CR</b>	<b>A</b>	<b>P</b>
			Rear			
			Left			
			Right			

Frequency Range (MHz)	RF Field Position	R.F. Field Strength	Azimuth	Observation	Perform. Criteria	Results
1000~6000	H / V	3 V/m (rms) AM Modulated 1000Hz, 80%	Front	<b>CT,CR</b>	<b>A</b>	<b>P</b>
			Rear			
			Left			
			Right			

Note:

1. The exclusion band has not been tested in 80MHz~6GHz.

The exclusion band for immunity testing of equipment operating in the 2,4 GHz band shall be: • lower limit of exclusion band = lowest allocated band edge frequency -120 MHz, i.e. 2 280 MHz; • upper limit of exclusion band = highest allocated band edge frequency +120 MHz, i.e. 2 603,5MHz.

2. "A" stand for, during test, operate as intended no loss of function, no degradation of performance, no unintentional transmissions and after test, no degradation of performance, no loss of function, no loss of stored data or user programmable functions.



**Mode 1**

Frequency Range (MHz)	RF Field Position	R.F. Field Strength	Azimuth	Perform. Criteria	Results
80~1000	H / V	3 V/m (rms) AM Modulated 1000Hz, 80%	Front	<b>A</b>	<b>P</b>
1000~6000			Rear		
1800			Left		
2600			Right		
3500					
5000					

Note: "A" stand for, during test, operate as intended no loss of function, no degradation of performance, no unintentional transmissions and after test, no degradation of performance, no loss of function, no loss of stored data or user programmable functions.

Note:

- 1) N/A - denotes test is not applicable in this test report.
- 2) There was not any unintentional transmission in standby mode
- 3) In the table: 'P' represents 'PASS'; 'F' represents 'FAIL'.

### AUX-Speaker.H

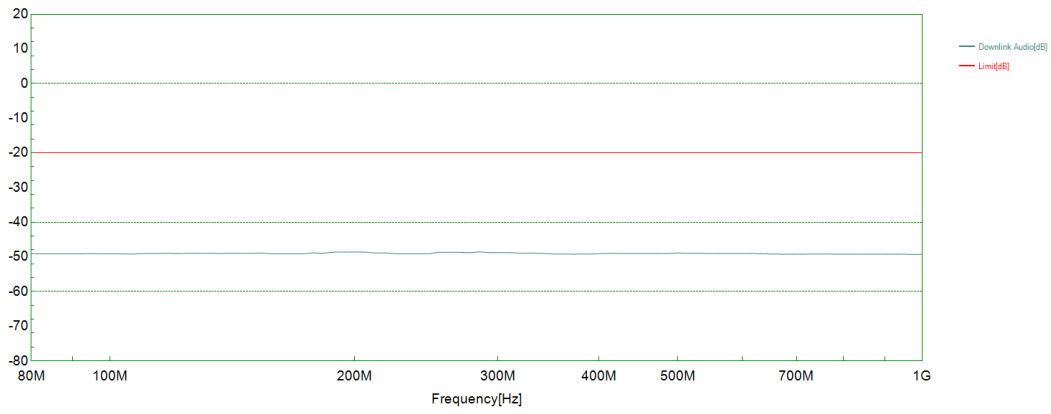

### AUX-Speaker.V

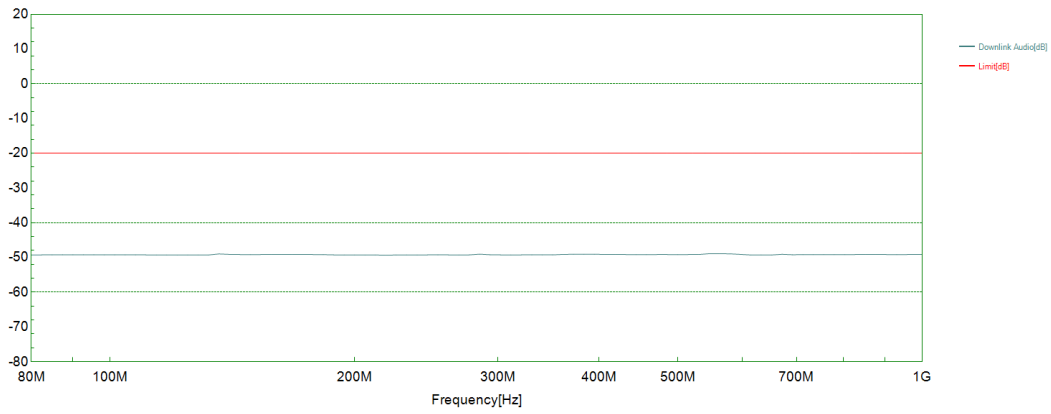

### USB-Speaker.H

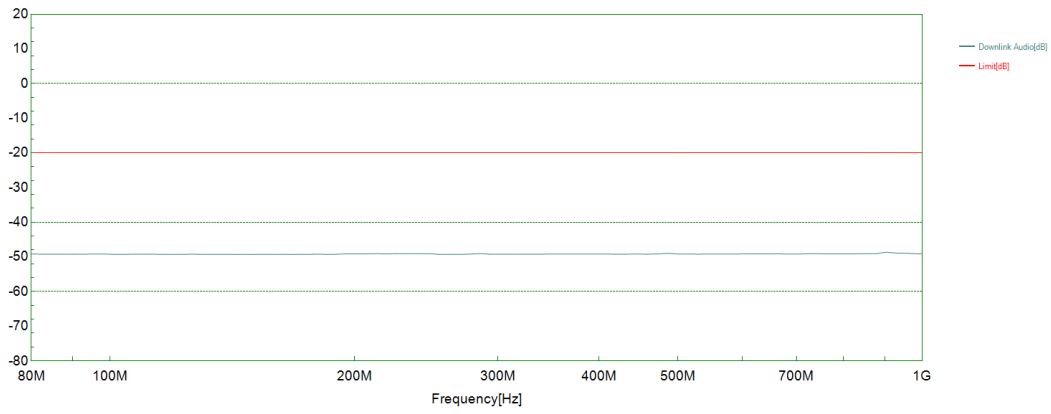

### USB-Speaker.V

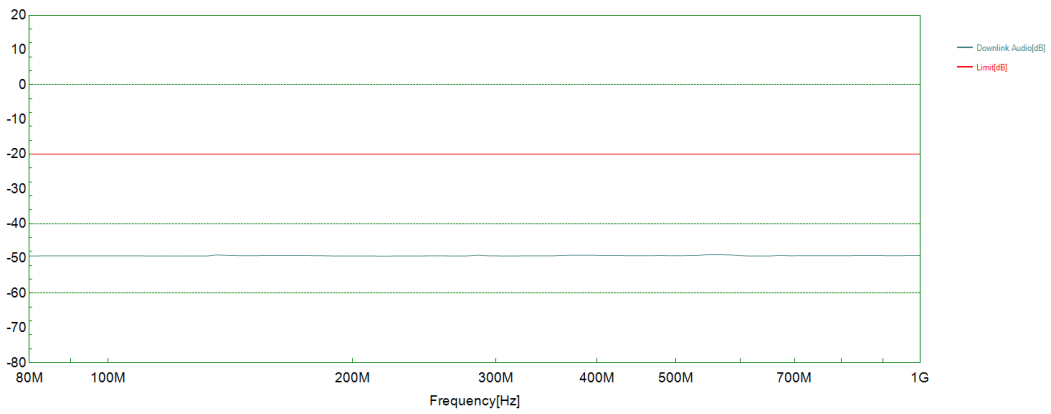

## 4.5 EFT/BURST TESTING

### 4.5.1 TEST SPECIFICATION

Basic Standard:	IEC/EN 61000-4-4
Required Performance	B
Test Voltage:	Power Line : 1 kV DC/Signal/ wired network Line : 0.5 KV
Polarity:	Positive & Negative
Impulse Frequency:	For xDSL wired network ports: 100 kHz For DC/AC ports: 5 kHz
Impulse Wave shape :	5/50 ns
Burst Duration:	15 ms
Burst Period:	300 ms
Test Duration:	Not less than 1 min.

### 4.5.2 TEST PROCEDURE

The EUT and support equipment, are placed on a table that is 0.8 meter above a metal ground plane measured 1m\*1m min. and 0.65mm thick min.

The other condition as following manner:

- a. The length of power cord between the coupling device and the EUT should not exceed 1 meter.
- b. Both positive and negative polarity discharges were applied.
- c. The duration time of each test sequential was 1 minute
- d. For the actual test configuration, please refer to the related Item –EUT Test Photos.



4.5.3 TEST SETUP

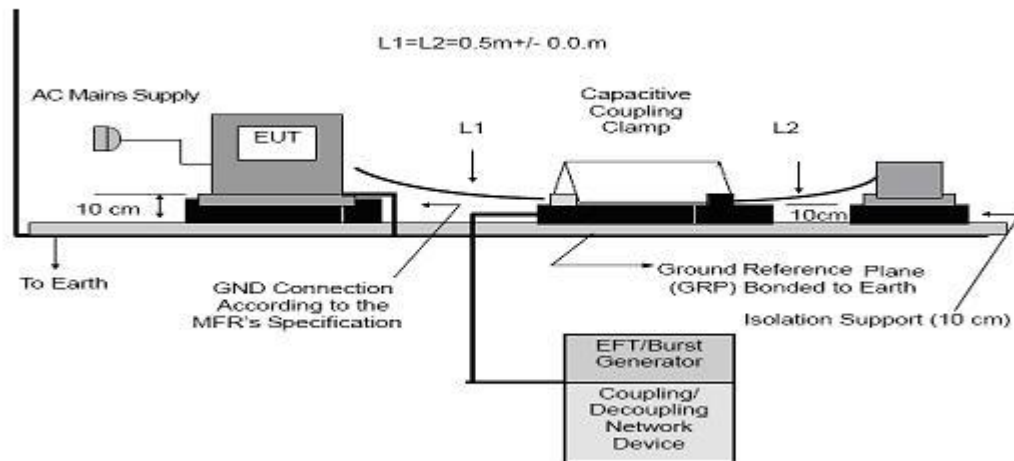
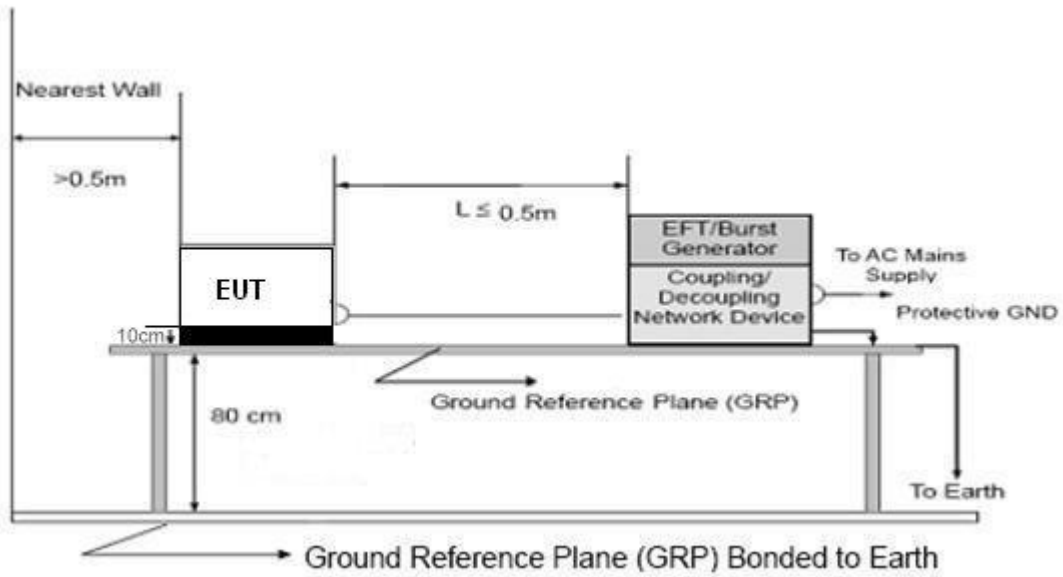

Note:

TABLE-TOP EQUIPMENT

The configuration consisted of a wooden table (0.8m high) standing on the Ground Reference Plane. The GRP consisted of a sheet of aluminum (at least 0.25mm thick and 2.5m square) connected to the protective grounding system. A minimum distance of 0.5m was provided between the EUT and the walls of the laboratory or any other metallic structure.

FLOOR-STANDING EQUIPMENT

The EUT installed in a representative system as described in section 7 of IEC/EN 61000-4-4 and its cables, were isolated from the Ground Reference Plane by an insulating support that is 0.1-meter thick. The GRP consisted of a sheet of aluminum (at least 0.25mm thick and 2.5m square) connected to the protective grounding system.

4.5.4 TEST RESULTS

EUT :	Computer Multimedia Speaker	Model Name :	R23BT
Temperature :	25 °C	Relative Humidity :	45%
Pressure :	1010 hPa	Test Power :	AC 230V/50Hz
Test Mode	Mode 1/2/3/4		

**TEST RESULT**

Mode 1

Coupling Line		Test level (kV)								Criterion	Result
		0.5		1		2		4			
		+	-	+	-	+	-	+	-		
AC line	L	P	P	P	P					B	Complies
	N	P	P	P	P						Complies
	PE										
	L+N	P	P	P	P						Complies
	L+PE										
	N+PE										
	L+N+PE										
DC Line											
Signal Line											

Mode 2/3/4

Coupling Line		Test level (kV)								Observation	Criterion	Result
		0.5		1		2		4				
		+	-	+	-	+	-	+	-			
AC line	L	P	P	P	P					TT,TR	B	Complies
	N	P	P	P	P							Complies
	PE											
	L+N	P	P	P	P							Complies
	L+PE											
	N+PE											
	L+N+PE											
DC Line												
Signal Line												

Note:

- 1) There was not any unintentional transmission in standby mode
- 2) In the table: 'P' represents 'PASS'; 'F' represents 'FAIL'.

4.6 SURGE TESTING

4.6.1 TEST SPECIFICATION

Basic Standard:	IEC/EN 61000-4-5
Required Performance	B
Wave-Shape:	Combination Wave 1.2/50 us Open Circuit Voltage 8 /20 us Short Circuit Current
Test Voltage:	Power Line:0.5 kV, 1 kV, 2 kV
Surge Input/Output:	L-N, L-PE, N-PE
Generator Source:	2 ohm between networks
Impedance:	12 ohm between network and ground
Polarity:	Positive/Negative
Phase Angle:	0 /90/180/270
Pulse Repetition Rate:	1 time / min. (maximum)
Number of Tests:	5 positive and 5 negative at selected points

4.6.2 TEST PROCEDURE

a. For EUT power supply:

The surge is to be applied to the EUT power supply terminals via the capacitive coupling network. Decoupling networks are required in order to avoid possible adverse effects on equipment not under test that may be powered by the same lines, and to provide sufficient decoupling impedance to the surge wave. The power cord between the EUT and the coupling/decoupling networks shall be 2meters in length (or shorter).

b. For test applied to unshielded unsymmetrically operated interconnection lines of EUT:

The surge is applied to the lines via the capacitive coupling. The coupling /decoupling networks shall not influence the specified functional conditions of the EUT. The interconnection line between the EUT and the coupling/decoupling networks shall be 2 meters in length (or shorter).

c. For test applied to unshielded symmetrically operated interconnection /telecommunication lines of EUT:

The surge is applied to the lines via gas arrestors coupling. Test levels below the ignition point of the coupling arrester cannot be specified. The interconnection line between the EUT and the coupling/decoupling networks shall be 2 meters in length (or shorter).

d. For the actual test configuration, please refer to the related Item –EUT Test Photos.



### 4.6.3 TEST SETUP

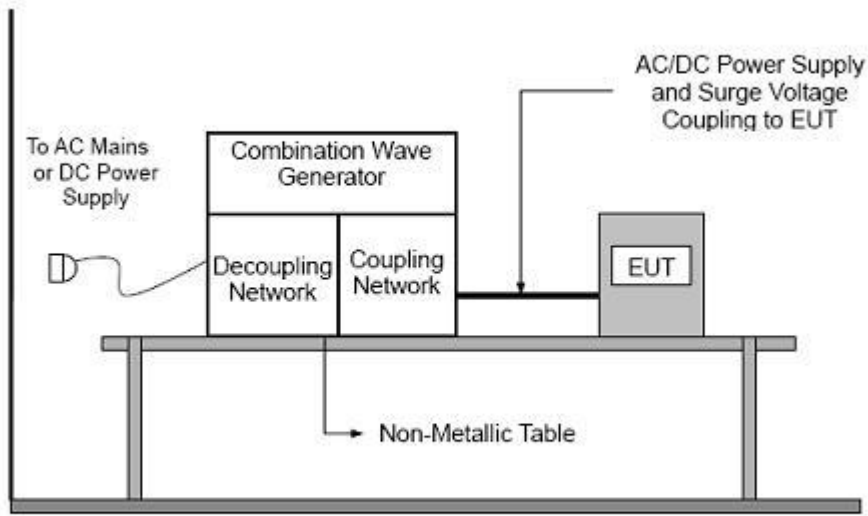

4.6.4 TEST RESULTS

EUT :	Computer Multimedia Speaker	Model Name :	R23BT
Temperature :	25 °C	Relative Humidity :	45%
Pressure :	1010 hPa	Test Power :	AC 230V/50Hz
Test Mode	Mode 1/2/3/4		

**TEST RESULT**

Mode 1

Coupling Line			Test level								Criterion	Result
			0.5 kV		1 kV		2 kV		4 kV			
			+	-	+	-	+	-	+	-		
AC line	L-N	0°	P	P	P	P					<b>B</b>	<b>Complies</b>
		90°	P	P	P	P						
		180°	P	P	P	P						
		270°	P	P	P	P						
	L-PE											
	N-PE											
DC Line												
Signal Line												

Mode 2/3/4

Coupling Line			Test level								Observation	Criterion	Result
			0.5 kV		1 kV		2 kV		4 kV				
			+	-	+	-	+	-	+	-			
AC line	L-N	0°	P	P	P	P					TT,TR	B	Complies
		90°	P	P	P	P							
		180°	P	P	P	P							
		270°	P	P	P	P							
	L-PE	0°											
		90°											
		180°											
		270°											
	N-PE	0°											
		90°											
		180°											
		270°											
DC Line													
Signal Line													

Note:

- 1) There was not any unintentional transmission in standby mode
- 2) In the table: 'P' represents 'PASS'; 'F' represents 'FAIL'.

4.7 INJECTION CURRENT TESTING

4.7.1 TEST SPECIFICATION

Basic Standard:	IEC/EN 61000-4-6
Required Performance	A
Frequency Range:	0.15 MHz - 80 MHz
Field Strength:	3 Vr.m.s.
Modulation:	1kHz Sine Wave, 80%, AM Modulation
Frequency Step:	1 % of fundamental
Dwell Time:	at least 3 seconds

4.7.2 TEST PROCEDURE

The EUT and support equipment, are placed on a table that is 0.8 meter above a metal ground plane measured 1m\*1m min. and 0.65mm thick min.

The other condition as following manner:

- a. The field strength level was 3V.
- b. The frequency range is swept from 150 KHz to 80 MHz, with the signal 80%amplitude modulated with a 1kHz sine wave. The rate of sweep did not exceed  $1.5 \times 10^{-3}$  decade/s. Where the frequency range is swept incrementally, the step size was 1% of fundamental.
- c. The dwell time at each frequency shall be not less than the time necessary for the EUT to be able to respond.
- d. For the actual test configuration, please refer to the related Item –EUT Test Photos.

4.7.3 TEST SETUP

Mobile Communication

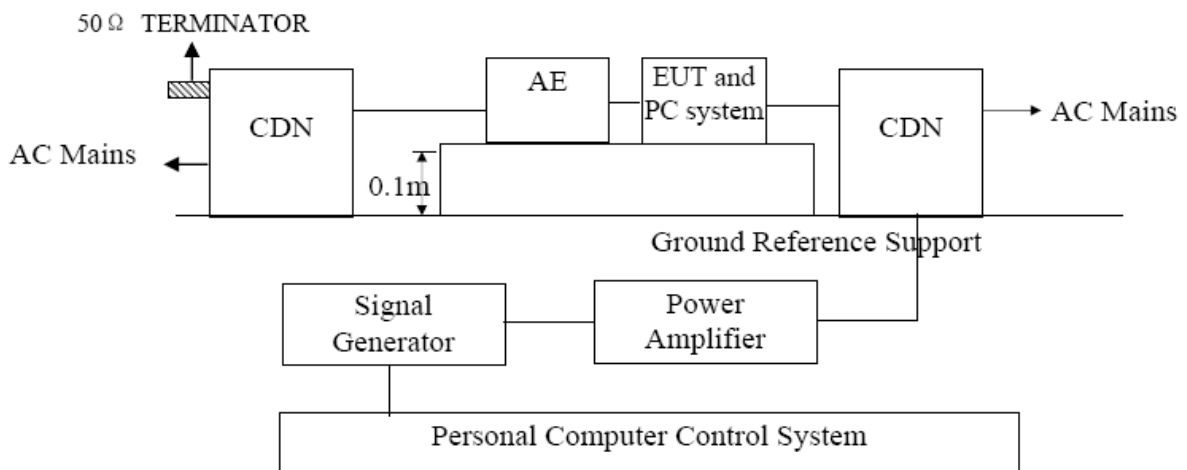



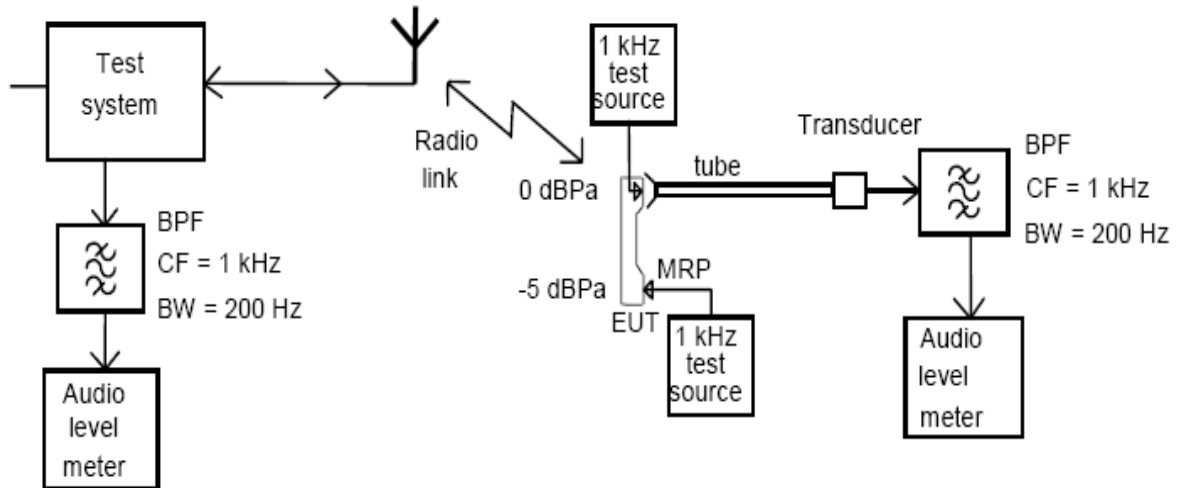

☒ General Communication

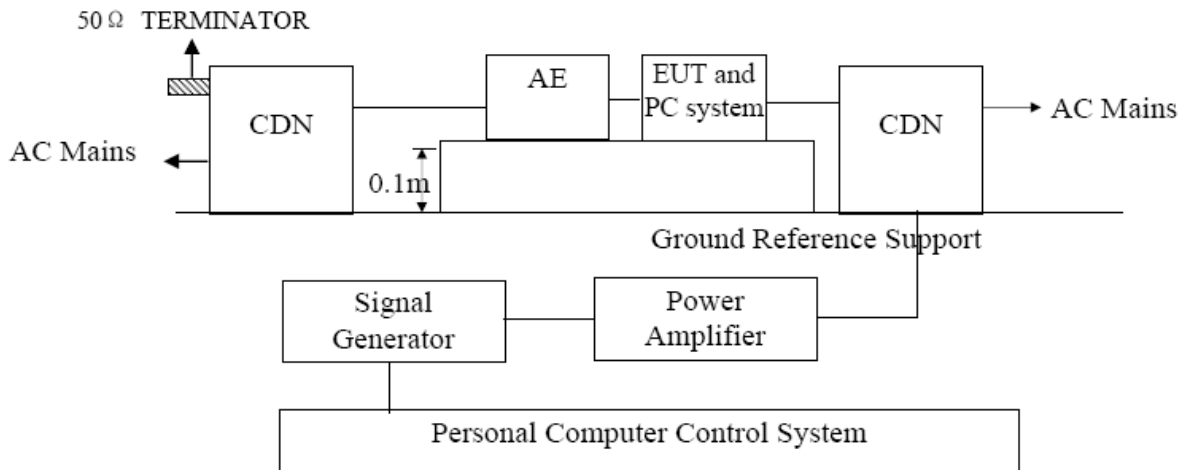

For the actual test configuration, please refer to the related Item –EUT Test Photos.

NOTE:

FLOOR-STANDING EQUIPMENT

The equipment to be tested is placed on an insulating support of 0.1 meters height above a ground reference plane. All relevant cables shall be provided with the appropriate coupling and decoupling devices at a distance between 0.1 meters and 0.3 meters from the projected geometry of the EUT on the ground reference plane.

#### 4.7.4 TEST RESULTS

EUT :	Computer Multimedia Speaker	Model Name :	R23BT
Temperature :	25 °C	Relative Humidity :	45%
Pressure :	1010 hPa	Test Power :	AC 230V/50Hz
Test Mode	Mode 1/2/3/4		

#### TEST RESULT

##### Mode 1

Test Ports (Mode)	Freq. Range (MHz)	Field Strength	Perform. Criteria	Results
Input/ Output AC. Power Port	0.15 ---80	3V(rms) AM Modulated 1000Hz, 80%	<b>A</b>	<b>P</b>
Input/ Output DC. Power Port	0.15 --- 80		<b>N/A</b>	<b>N/A</b>
Signal Line	0.15 --- 80		<b>N/A</b>	<b>N/A</b>

##### Mode 2/3/4

Test Ports (Mode)	Freq. Range (MHz)	Field Strength	Observation	Perform. Criteria	Results
Input/ Output AC. Power Port	0.15 ---80	3V(rms) AM Modulated 1000Hz, 80%	<b>CT, CR</b>	<b>A</b>	<b>P</b>
Input/ Output DC. Power Port	0.15 --- 80		<b>N/A</b>	<b>N/A</b>	<b>N/A</b>
Signal Line	0.15 --- 80		<b>N/A</b>	<b>N/A</b>	<b>N/A</b>

Note: "A" stand for, during test, operate as intended no loss of function, no degradation of performance, no unintentional transmissions and after test, no degradation of performance, no loss of function, no loss of stored data or user programmable functions.

### Test plot AUX-Speaker.AC

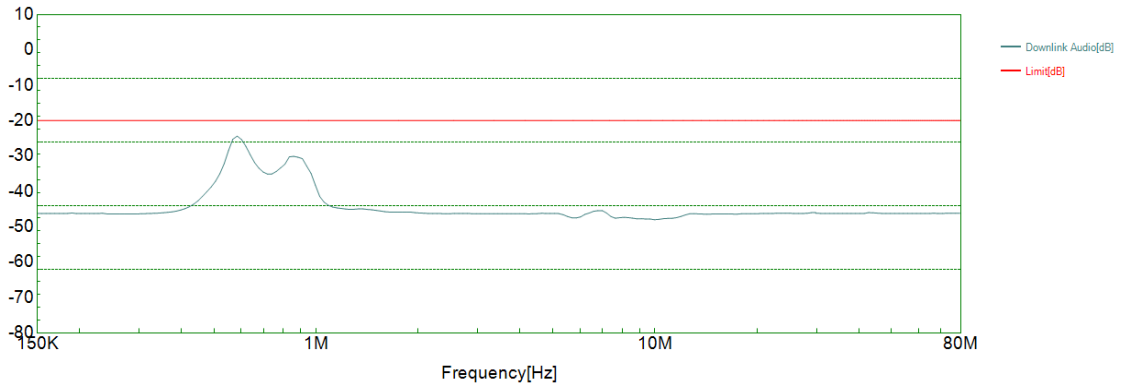

### USB-Speaker.AC

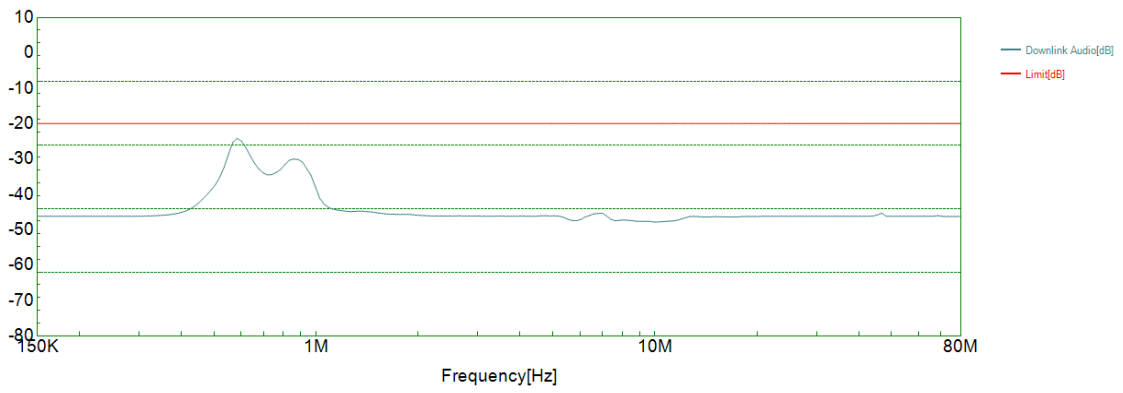

#### 4.8 VOLTAGE INTERRUPTION/DIPS TESTING

##### 4.8.1 TEST SPECIFICATION

Basic Standard:	IEC/EN 61000-4-11
Required Performance	100% reduction, 0.5 Cycle 100% reduction, 1.0 Cycle 30% reduction, 25 Cycles 30% reduction, 0.5 Cycle
Voltage Interruptions:	100% reduction, 250 Cycles
Test Duration Time:	Minimum three test events in sequence
Interval between Event:	Minimum ten seconds
Phase Angle:	0°/45°/90°/135°/180°/225°/270°/315°/360°
Test Cycle:	3 times

##### 4.8.2 TEST PROCEDURE

The EUT shall be tested for each selected combination of test levels and duration with a sequence of three dips/interruptions with intervals of 10 s minimum (between each test event). Each representative mode of operation shall be tested. Abrupt changes in supply voltage shall occur at zero crossings of the voltage waveform.

##### 4.8.3 TEST SETUP

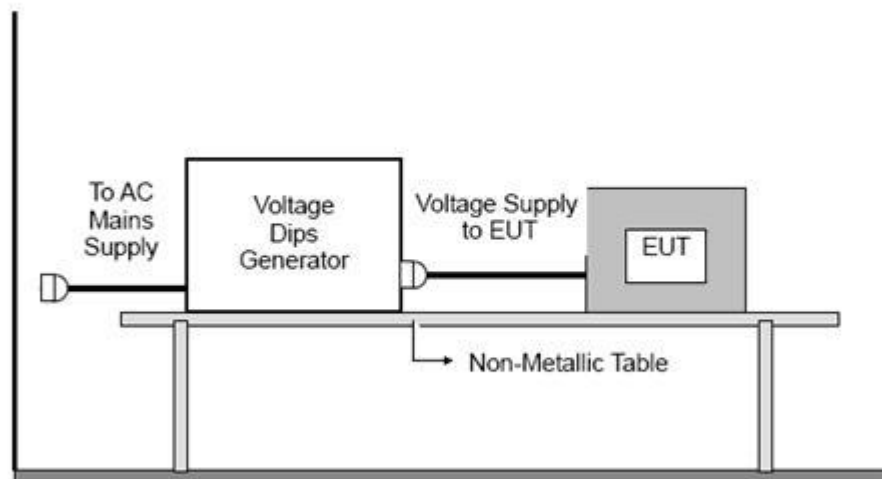

For the actual test configuration, please refer to the related Item –EUT Test Photos.



4.8.4 TEST RESULTS

EUT :	Computer Multimedia Speaker	Model Name :	R23BT
Temperature :	25 °C	Relative Humidity :	45%
Pressure :	1010 hPa	Test Power :	AC 230V/50Hz
Test Mode	Mode 1/2/3/4		

TEST RESULT

Mode 1

Voltage Reduction	Duration (ms)	Perform Criteria	Results
Voltage dip: 0%	10	<b>B</b>	<b>P</b>
Voltage dip: 0%	20	<b>B</b>	<b>P</b>
Voltage dip: 70%	500	<b>C</b>	<b>P</b>
Voltage interruptions: 0%	5000	<b>C</b>	<b>P</b>

Mode 2/3/4

Voltage Reduction	Duration (ms)	Observation	Perform Criteria	Results
Voltage dip: 0%	10	<b>TT, TR</b>	<b>B</b>	<b>P</b>
Voltage dip: 0%	20	<b>TT, TR</b>	<b>B</b>	<b>P</b>
Voltage dip: 70%	500	<b>TT, TR</b>	<b>C</b>	<b>P</b>
Voltage interruptions: 0%	5000	<b>TT, TR</b>	<b>C</b>	<b>P</b>

Note:

- 1) There was not any unintentional transmission in standby mode
- 2) In the table: 'P' represents 'PASS'; 'F' represents 'FAIL'.

5. EUT TEST PHOTO

Radiated Measurement Photo

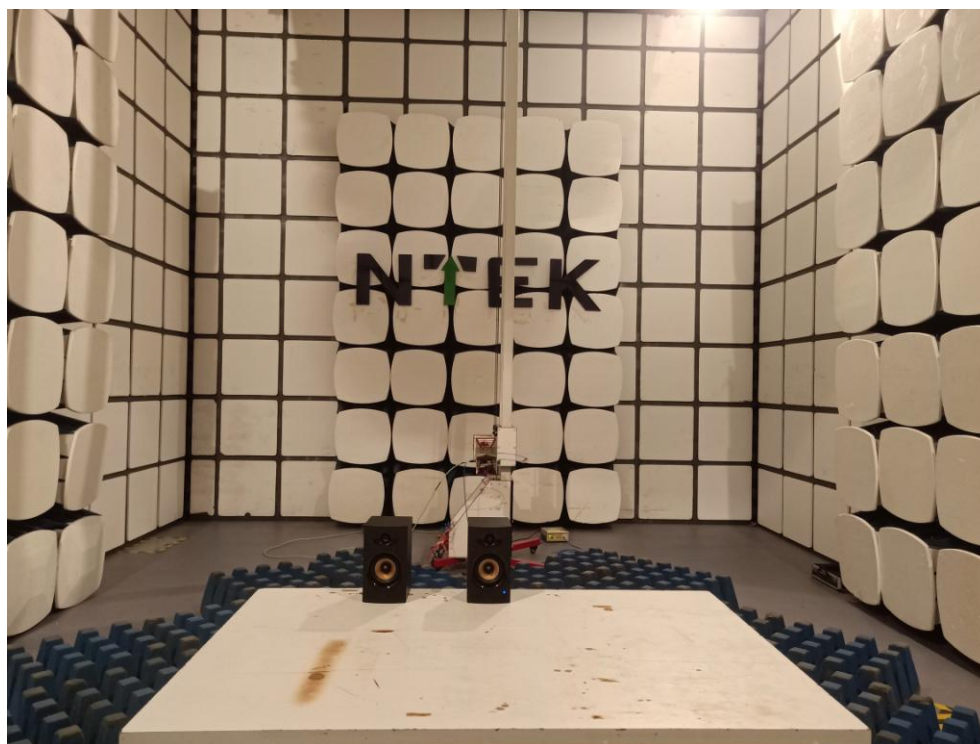

Conducted Measurement Photo

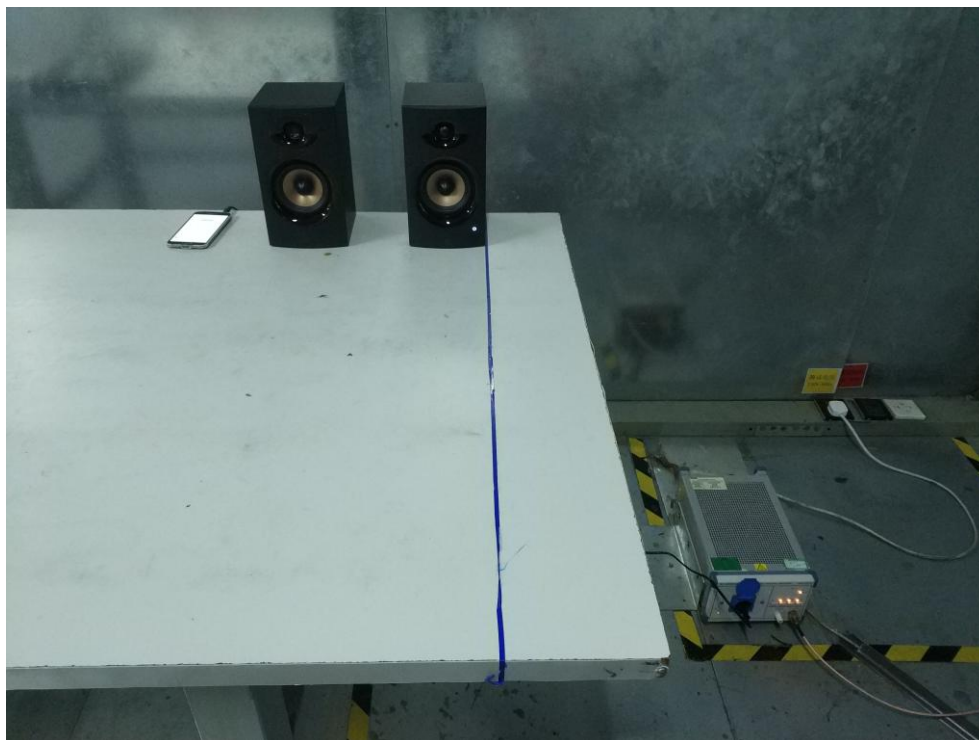

END OF REPORT